

Smart Heating Solutions

60
Years

We Believe Experience Matters





QUALITY IS KING

ELECTRIC HEATER
MANUFACTURING

EST. 1958 · SEATTLE, WA

KING-ELECTRIC.COM

Celebrating 60 Years of American Comfort

Since 1958, King Electric has delivered American Made, smart comfort products to homes and families through industry leading innovation, building a legacy of trust, and delivering unparalleled reliability.

After 60 years of manufacturing high-quality American-made electric heaters, we can not forget our partners in the field that make KING what it is today. To all of the electrical distributors and electricians that have supported us over the years, we say Thank You. Discover all the ways King has redefined Comfort, today and for the next 60 years.

Fan-Driven Heaters



**W Series
Wall Heater**

120/208/240V / 500-2,000W

Page 1-2



**WHF Series
Wall Heater**

120/208/240V / 500-2,000W

Page 3-4



**PAW Series
Wall Heater**

120/208/240/277V / 250-2,250W

Page 5-7



**PAW Ultra Series
Wall Heater**

120/208/240/277V / 250-2,250W

Page 8

ComfortCraft



**PX Series
Wall Heater**

120/208/240V / 250-1,750W

Page 9-10

eco2s



**PX ECO2S Series
Electronic Wall Heater**

120/208/240V / 750-1,750W

Page 11-12



**WHF-HM Series
High Wall Heater**

120/208/240V / 500-2,000W

Page 13-14



**SL Series
Surface Mount Heater**

120/208/240V / 250-2,250W

Page 15-16

**NEW
Multi-Watt
Design**



**EFW-MW Series
Economy Large Wall Heater**

120/208/240V / 2,000-4,000W

Page 17-18

ComfortCraft



**LPW Series 2
Large Wall Heater**

120/208/240/277V / 1,250-4,500W

Page 19-20

eco2s



**LPX ECO2S Series
Large Wall Heater**

120/208/240V / 1,500-4,500W

Page 21-22



**LPWW Series
Vandal Resistant Heater**

120/208/240/277V / 500-1,500W

Page 23-24



**LPWA Series
Architectural Heater**

120/208/240/277V / 1,500-4,500W

Page 25-26



**KT-MW Series
Kickspace Heater**

120/240V / 250-1,500W

Page 27-28



**KTW Series
Convertable Kickspace Heater**

120/240V / 250-1,500W

Page 29-30

Ceiling Heaters



**WHFC Series
Ceiling Heater**

120/208/240V / 500-1,500W

Page 31



**LPWC Series
Ceiling Heater**

120/208/240/277V / 1,250-4,000W

Page 32

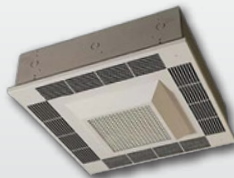

**KDS Series
Ceiling Diffuser**

208/240/277/480V / 2,000-10,000W

Page 33-35

Baseboard Heaters

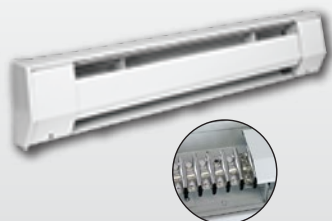

**K Series
Baseboard Heater**

120/208/240/277V / 375-2,400W

Page 36-38

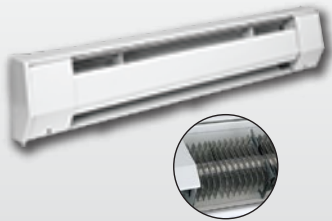

**CB Series
Ceramic Baseboard Heater**

120/208/240V / 350-1,500W

Page 38-40



**KCV Series
Cove Heater**

120/208/240V / 210-1,800W

Page 41-42

Thermostats



ATMOZ WiFi

**Electronic Programmable
Smart Phone APP**

208/240V / 16A / Single/Double Pole

Page 43-44

ClearTouch



**K302PE / K322E
7-Day Programmable**

120/208/240V / 15A / Double Pole

Page 45-46

ClearTouch



**K312RELAY
Relay Unit**

120/208/240V / 15A / Double Pole

Page 45-46

SIMPLSTAT



**SIMPLSTAT Series
Personalized Presets**

120/208/240V / 16A / Single/Double Pole

Page 47



**ES / ESP Series
Electronic Thermostat**

120/208/240V / 22A / Single Pole

Page 48

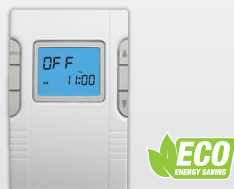

**WR / WRP Series
Programmable Thermostat**

120/208/240V / 16A / Single Pole

Page 49

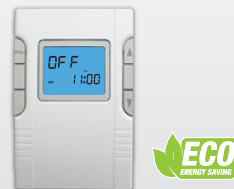

**HP Series
Two Circuit Thermostat**

120/208/240V / 16A per Pole / Dual Single Pole

Page 50



**Autonomous Series
Dual Timed Thermostat**

120/208/240V / 16A / Double Pole

Page 51

King Electrical Manufacturing Company

Thermostats



K101 / K102
& K101-C Cooling
Line Voltage Thermostat

120/208/240/277V / 22A

Page 52-53



EP-3/1F56W/1F57/1E30
Line Voltage Thermostats

24V

Page 54



TF115
N.E.M.A. 4X
Line Voltage Thermostat

120/208/240/277/480V / 25A

Page 54



HW / HWP / HWPT
HB / HBP Series
Hydronic Thermostats

Page 160-162

Personal Portable Heaters



PH-7
Electronic Portable Heater

120V / 1,500W

Page 55



PH-2 / PH-16
Portable Ceramic Heaters

120V / 1,500W

Page 56-57



KP1215-ECO
ECO Portable Baseboard

120V / 750/1,500W

Page 58



KP / KPH Series
Portable Baseboard

120V / 1,000W

Page 59



PUH1215T
Portable Utility Heater

120V / 750/1,500W

Page 60



PSH1215T Yellow Jacket
Portable Shop Heater

120V / 1,500W

Page 61



PSH2440TB Yellow Jacket
Portable Shop Heater

240V / 4,000W

Page 62



PGH2448-ETB ECO2S
Portable Utility Heater

240V / 4,800W

Page 63

Radiant Heaters



PGH2440TB / PGH2448TB
Portable Utility Heater

240V / 4,000/4,800W

Page 63



RSH1215
Portable Radiant Heater

120V / 1,500W

Page 64



RH Series
Radiant Heater

120/208/240/480/575V / 1,600-11,400W

Page 65-69

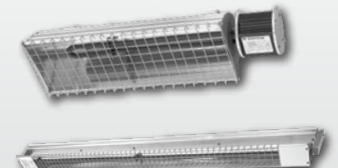

OK Series
Radiant Heater

120/208/240/480V / 1,600-5,000W

Page 70-71

Pumphouse Heaters



U Series
Pumphouse Heater
120/240V / 62-1,000W

Page 72

SafeTouch



KCF/KCF Safetouch Series
Fan Forced Cabinet Heater
208/240/277/480V / 2,000-5,000W
208/240/277/480V / 500-2,000W

Page 73-75

Cabinet Heaters



KCC Series
Convection Cabinet Heater
208/240/277/480V / 2,000-5,000W

Page 76-77



KCA Series
Cabinet Heater
208/240/277/480V / 1,000-24,000W

Page 78-80

Cabinet Heaters



KLA Series
Architectural Cabinet Heater
208/240/277V / 1,500-6,000W

Page 81-82



KLI Series
Architectural Cabinet Heater
208/240/277V / 1,500-6,000W

Page 83-84

Draft Barrier Heaters



SB Series
Draft Barrier
120/208/240/277V / 400-2,500W

Page 85-86



LB Series
Draft Barrier
120/208/240/277V / 376-5,000W

Page 87-89

Draft Barrier Heaters



KDBA Series
Architectural Draft Barrier
120/208/240/277V / 225-2,500W

Page 90-91



KDia Series
Architectural Draft Barrier
120/208/240/277V / 225-2,500W

Page 92-93

Unit Heaters



EKB Series
Garage/Shop Heater
120, 208, 240V / 1,920-5,000W

Page 95-96



KBP Series
Unit Heater
120/208/240/277/480V / 950-6,000W

Page 97-98



GH Series
Unit Heater
208/240V / 5,000-10,000W

Page 99-100



SKB Series
Unit Heater
208/240V / 5,000-10,000W

Page 101-102



KB Series
Unit Heater
208/240V / 3,300-40,000W

Page 103-106



KB ECO2S Series
Electronic Unit Heater
208/240V / 4,000-15,000W

Page 107-108

King Electrical Manufacturing Company

Unit Heaters



**KB Platinum Series
Electronic Unit Heater**
208/240/277/480V / 3,300-40,000W

Page 109-111



**KB Platinum Series
Double Electronic Unit Heater**
208/240/277/480V / 25,000-40,000W

Page 109-111



**KBS Series
Stainless Steel Unit Heater**
208/240/277/480V / 3,000-20,000W

Page 112-113



**KFUH Series
High Capacity Unit Heater**
208/240/480V / 3,000-34,500W

Page 114-116

Plenum Heaters



**CK Series
Plenum Heater**
208/240/480V / 3,300-33,000W

Page 117-119



**CKL Series
Plenum Heater**
208/240/480V / 30,000-240,000W

Page 120-123

Explosion-Proof Heaters



**FX5 Series
Explosion-Proof Heater**
208/240/277/380/400/415/480/600V
3,000-35,000W

Page 124-127



**CX1 Series
Explosion-Proof Heater**
120/208/240/277/380/400/415/480/600V
1,200-7,600W

Page 128-130

Industrial Portable Heaters



**PKB Platinum Series
Industrial Electronic
Portable Utility Heater**
208/240/480V / 10,000-30,000W

Page 131-132



**PCK Series
Industrial Portable Unit Heater**
208/240/480V / 10,000-30,000W

Page 133-134

Electric Furnaces



**KF / KFS Series
Electric Furnace**
208/240/480V / 3,000-34,500W

Page 135-139



**KFS Endura Series
Electric Furnace**
208/240V / 8,000-30,000W

Page 140-141

Marine Heaters

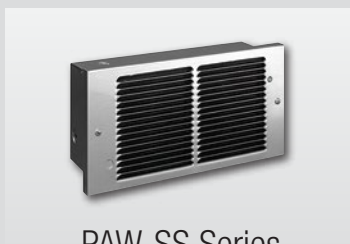

**PAW-SS Series
Stainless Steel Marine Heater**
120/208/240/277V / 250-2,250W

Page 142-143

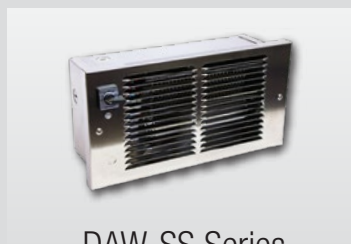

**DAW-SS Series
Stainless Steel Marine Heater**
120/208/240/277V / 250-2,250W

Page 144



**MKT-SS Series
Stainless Steel Marine Heater**
120/240V / 375-1,500W

Page 145

Electric Duct Heaters



R Series
In-Line Duct Heating System

120V/1440W

Page 146, 149



E Series
Flippable Electric Duct Heater

120/208/240/277/480V

Page 147, 149



DHC / DC Series
Electric Duct Heater

120/208/240/277/480/600V

Page 148-149

Hydronic Heaters

 HYDRONIC



HLB / HSB Series
Draft Barrier

400 to 1,000 BTU per FT.

Page 151-154

 HYDRONIC



H Series
Small Hydronic Heater

120V / 1,800 - 10,500 BTU

Page 155

 HYDRONIC



HT Series
Kick-Space Hydronic Heater

120V / 1,700 - 9,950 BTU

Page 156-157

 HYDRONIC



HM / HME Series
Medium Hydronic Heater

120V / 4,960 - 18,700 BTU

Page 158

 HYDRONIC



HL / HLE Series
Large Hydronic Heater

120V / 6,700-27,250 BTU

Page 159

 HYDRONIC



HW / HWP / HWPT Series
Hydronic Thermostats

120V / 12.5A

Page 160

 HYDRONIC



HB / HBP Series
Electronic Hydronic Thermostat

120/208/240V / 16A per Pole / Dual Single Pole

Page 161-162

 HYDRONIC



HI Series
Boiler Conversion

208/240/277V / 563-2,250 BTU

Page 163

Electric In-Floor Heat



FC Series
Electric In-Floor Cable

120/240V / 120-2880W

Page 166



FCM Series
Electric In-Floor Mat

120/240V / 120-1920W

Page 167



Floor Heating
& Thermal Storage
Thermostats & Accessories

Page 168

King Electrical Manufacturing Company

Thermal Storage



**TC Series
Thermal Storage Cable**

240V / 6W/LinFt

Page 170



**TCM Series
Thermal Storage**

240V / 12-14W/SqFt

Page 171



**SC Series
Snow Melt Cable**

208/240/480V / 12W/Lin Ft

Page 173



**SCM Series
Snow Melt Mats**

208/240/480V / 36-40W/SqFt

Page 174-176

Pipe Freeze Protection



**SRP Series
Pipe Trace Cable**

Pre-Assembled Self-Regulating
120/240V / 6W/LinFt @ 40°F

Page 178



**CWP Series
Pipe Trace Cable**

Constant Wattage
120V / 7W/LinFt

Page 179



**SR Series
Pipe Trace Cable**

Self-Regulating
120/240V / 3/5/8/10W/LinFt @ 40°F°

Page 180-181



**CT Series
Pipe Trace Cable**

Self-Regulating
120/240V / 3/5/8/10W/LinFt @ 40°F°

Page 181

Roof/Gutter De-Icing



**SRP Series
De-Icing Cable**

Pre-Assembled Self-Regulating
120/240V / 8W/LinFt @ 32°F

Page 183



**CWR Series
De-Icing Cable**

Constant Wattage
120V / 7W/Ft

Page 184



**CWR IceFree™ Controller
Ice Melt System**

Constant Wattage
120V / 10A / 1200W

Page 184



**SR Series
De-Icing Cable**

Self-Regulating
120/240V / 5/8/12.1/14.8W / LinFt @ 32°F°

Page 185



**CT Series
De-Icing Cable**

Self-Regulating

120/240V / 5/8/12.1/14.8W / LinFt @ 32°F°

Page 186

Controls, Sensors & Accessories



**SnowFree™ Controller
Snow Melt System**

2 Zone / 24A per Zone

Page 194



**PYRO Series
Snow Melt De-Icing System**

Up to 4 Zones / GFCI

Page 195-196



**PYRO FPC Series
Freeze Protection
Controller**

120/240V / 30A / GFEP / ModBus

Page 197



**PYRO Series
Pipe Trace System**

Up to 4 Zones / GFCI

Page 198



**SR/SRP Series
Accessories**

Page 199



**Roof/Drain
De-Icing System**

Page 200



**Controls & Sensors
Roof & Gutter**

Page 201



**Controls & Sensors
Pipe Freeze**

Page 201

High Velocity Drum Fans



**Controls & Sensors
Snow Melt**

Page 201



**DFC Series
Direct Drive**

24"/30"/36" / 24"/30" Swivel Base

Page 203



**DFC Series
Belt Drive**

36"/42"/48"

Page 204

TV Rough-In



**TVR Series
TV Rough-In
Mounting System**

Page 205

Wall Heater W Series

Model Code:

W	12	10	-T2
A	B	C	D
A: Series			
B: 12 - 120V 24 - 240V			
20 - 208V			
C: Watts (500 to 2000)			
D: Thermostat (optional)			



- Nichrome Open-Coil element
- C-Frame motor
- 4-Blade aluminum fan
- Patented Smart Limit Protection®
- 20 gauge powder-coated grill
- Standard color: white (Almond color optional)
- 20 gauge electro-galvanized steel recess can
- Wall can with QuickSet™ stud alignment tabs
- Dual wattage & available in 120, 208, 240 Volts
- 1-year limited warranty



The "W" Wall Heater

The W Heater was designed to be the highest quality economy heater on the market. It is commonly used in apartment construction or as supplemental heat in single family homes. By combining an efficient impeller style fan with a NiChrome heating element, the W heater delivers instant heat in even the draftiest locations. For use with a wall thermostat or in-built thermostat. A powder-coated, surface mounted wall-can may be purchased separately. The wall can shall be 20 gauge electro-galvanized steel and contain knockouts through which power leads are brought. The wall can shall be able to mount directly to wall studs in new or existing construction. The wall can shall be provided with QuickSet™ stud alignment tabs, used for maintaining proper depth during new installation. The wall can shall be supplied with a factory installed ground wire. Clearance: 6" to a side wall, 4" from floor minimum.

Ordering Information *Add suffix -W for White Grill or -A for Almond Grill

	BASE MODEL	VOLTS	WATTS	AMPS	SHIP WEIGHT lbs
120V	W1210	120	1000 or 500	8.3 or 4.2	8
	W1212	120	1200 or 600	5 or 2.5	8
	W1215	120	1500 or 750	12.5 or 6.3	8
208V	W2010	208	1000 or 500	4 or 2.4	8
	W2015	208	1500 or 750	7.2 or 3.6	8
	W2020	208	2000 or 1000	9.6 or 4.8	8
240V	W2410	240	1000 or 500	4.1 or 2.1	8
	W2412	240	1200 or 600	5 or 2.5	8
	W2415	240	1500 or 750	6.25 or 3.1	8
	W2420	240	2000 or 1000	8.3 or 4.2	8

Factory Installed Options

ADD SUFFIX	DESCRIPTION	SHIP WEIGHT lbs
-W	White Color	8
-A	Almond Color	8
H	Heatbox Interior Only (No Can or Grill)	6
-T	Factory Installed Single Pole Thermostat Kit	8
-T2	Factory Installed Double Pole Thermostat Kit	8
-DS15	Factory Installed Double Pole Disconnect (10A/ 240V / 15A/120V)	8

NOTE: Not all configurations listed above are stock items (A+ or A stock code). Refer to price book for the Stock code. For non-stock items refer to the table below to order heater parts separately.

Order A'la Carte Follow steps 1, 2 and 3 below to order a heater from separate parts.

STEP 1: Order Heatbox Interior

ADD SUFFIX	DESCRIPTION	SHIP WEIGHT lbs
-I	Heatbox Interior and Grill	6
-H	Heatbox Interior	6

Wall Heater W Series

STEP 2: Order Wall Can

MODEL	UPC	DESCRIPTION	SHIP WEIGHT lbs
UIC	12640	Recess Wall Can	3.5
UICF	12540	Recess Can with Flange (remodel)	4
WSC	19202	Surface Can - White 13.5" L x 10" W x 4"H	4
WSC-A	19203	Surface Can - Almond 13.5" L x 10" W x 4"H	4

STEP 3: Order Grill (not required for -I models)

MODEL	UPC	DESCRIPTION	SHIP WEIGHT lbs
WG-W	11914	Grill - White	4
WG-A	12785	Grill - Almond	4
WOG	19200	10" W x 17" H Retrofit Grill	3
WOG-A	18605	10" W x 17" H Retrofit Grill - Almond	3
WOG-XL-W	18606	14" W x 13.5" H Retrofit Grill - White	3

NOTE: This is the quickest option when the factory installed heaters options are not in stock.

Accessories

MODEL	UPC	DESCRIPTION	SHIP WEIGHT lbs
TKIT-1BW	20654	Built-in Single Pole Single Throw Thermostat Kit, Bright White	0.5
TKIT-2BW	20655	Built-in Double Pole Single Throw Thermostat Kit, Bright White	0.5
TKIT-1A	11058	Built-in Single Pole Single Throw Thermostat Kit, Almond	0.5
TKIT-2A	11059	Built-in Double Pole Single Throw Thermostat Kit, Almond	0.5

Engineering Specifications

Contractor shall supply and install W Series in-wall mounted forced-air electric heaters manufactured by King Electrical Mfg. Company.

Heaters shall be of the wattage and voltage as indicated on the plans.

Ratings: Wattages of 500 to 2,000 at 120, 208 or 240 Volts are available. Heaters shall provide air movement at 85 CFM.

Fan and Motor: Motor shall be shaded pole, permanently lubricated, C-frame type with impedance protection and sealed bearings. Motors shall be the same voltage as the heater. The motor and all wiring shall be totally isolated from the heating chamber for protection from heated air. The motor shall be equipped with a dynamically balanced four-blade aluminum impeller fan, located in the upper portion of the heat box, and shall provide a down-flow heating pattern.

Elements: Assemblies shall be constructed of coiled Nickel Chromium alloy, corrosion-resistant wire strung through a minimum of four rows of mica insulator. Element assemblies shall have factory provided connection to allow field modification to 50% wattage at time of installation.

Smart Limit Thermal Protection: Turns off heater during any unsafe temperatures on inlet or outlet and will only reset if power is interrupted for 10 minutes. Simply turning thermostat down below set point will reset. Exclusive King design and patented for US and Canada under #6,748,163 B2 and #2,393,882

Wall Can with QuickSet™ stud alignment tabs: The wall can shall be 20 gauge electro-galvanized steel and contain knockouts through which power leads are brought. The wall can shall be able to mount directly to wall studs in new or existing construction. The wall can shall be provided with QuickSet™ stud alignment tabs, used for maintaining proper depth during new installation. The wall can shall be supplied with a factory installed ground wire. Clearance: 6" to a side wall, 4" from floor minimum.

Grill: The grill shall be a louvered, one-piece design with rounded edges on all four sides, with rounded corners to prevent snags from contact with other materials. The grill shall be epoxy powder-coated in the color specified by manufacturer.

Approvals: cULus (E41422)

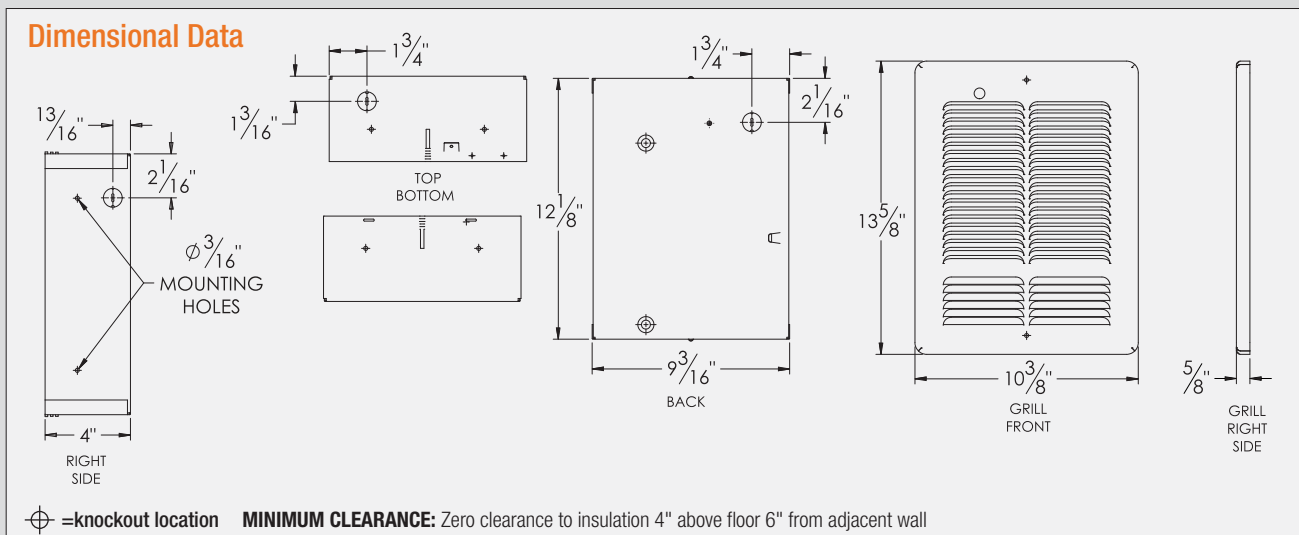

Wall Heater WHF Series



Model Code:

WHF	12	10	-A	-H	-I
A	B	C	D	E	F

A: Series
 B: 12 - 120V 24 - 240V
 20 - 208V
 C: Watts (500 to 2000)
 D: Color E: Interior Only
 F: Interior & Grille



- NiChrome Open-Coil Element
- Squirrel Cage Blower
- Whisper Quiet
- Patented Smart Limit Protection®
- 20 gauge powder-coated grill
- Standard color: white
- (Almond color optional)
- C-Frame Motor
- 20 gauge electro-galvanized steel recess can with
- Wall can with QuickSet™ stud alignment tabs
- Dual Wattage & available in 120, 208, or 240 Volts
- 3-year limited warranty

The WHF Wall Heater

The WHF heater offers extreme value by combining the rapid heat transfer of a NiChrome element with the performance of a squirrel cage blower. This makes for a relatively quiet heater without the added cost of a high mass element like the Pic-A-Watt®. It is commonly used as the first upgrade in apartment construction and is an excellent choice for bathrooms because of the instant heat from the wire element. The wall can shall be 20 gauge electro-galvanized steel and contain knockouts through which power leads are brought. The wall can shall be able to mount directly to wall studs in new or existing construction. The wall can shall be provided with QuickSet™ stud alignment tabs, used for maintaining proper depth during new installation. The wall can shall be supplied with a factory installed ground wire. Clearance: 6" to a side wall, 4" from floor minimum.

Ordering Information *Add suffix -W for White Grill or -A for Almond Grill

	BASE MODEL	VOLTS	WATTS	AMPS	SHIP WEIGHT lbs
120V	WHF1210	120	500 • 1000	4.2 - 8.4	8.0
	WHF1212	120	600 • 1200	5.0 - 10.0	8.0
	WHF1215	120	750 • 1500	6.3 - 12.5	8.0
208V	WHF2010	208	500 • 1000	2.4 - 4.8	8.0
	WHF2015	208	750 • 1500	3.6 - 7.2	8.0
	WHF2020	208	1000 • 2000	4.8 - 9.6	8.0
240V	WHF2410	240	500 • 1000	2.1 - 4.2	8.0
	WHF2412	240	600 • 1200	2.5 - 5.0	8.0
	WHF2415	240	750 • 1500	3.1 - 6.2	8.0
	WHF2420	240	1000 • 2000	4.2 - 8.4	8.0

Factory Installed Options

ADD SUFFIX	DESCRIPTION	SHIP WEIGHT lbs
-W	White Color	8.0
-A	Almond Color	8.0
-H	Heatbox Interior Only (no can or grill)	6.0
-I	Heatbox Interior and Grill Only (no wall can)	6.0
-DS15	Factory Installed Double Pole Disconnect (10A/ 240V / 15A/120V)	8.0

NOTE: Not all configurations listed above are stock items (A+ or A stock code). Refer to price book for the Stock code. For non-stock items refer to the table below to order heater parts separately.

Order A'la Carte Follow steps 1, 2 and 3 below to order a heater from separate parts.

STEP 1: Order Heatbox Interior

ADD SUFFIX	DESCRIPTION	SHIP WEIGHT lbs
-I	Heatbox Interior and Grill	6.0
-H	Heatbox Interior	6.0

Wall Heater WHF Series

STEP 2: Order Wall Can

MODEL	UPC	DESCRIPTION	SHIP WEIGHT lbs
UIC	12640	Recess Wall Can	3.5
UICF	12540	Recess Can with Flange (remodel)	4.0
WHSC-W	19204	Surface Can - White - 13.5" H x 10.125" W x 4" D	4.0
WHSC-A	19205	Surface Can - Almond - 13.5" H x 10.125" W x 4" D	4.0

STEP 3: Order Grill (not required for -I models)

MODEL	UPC	DESCRIPTION	SHIP WEIGHT lbs
WHFG-W	12520	Grill - White	2.0
WHFG-A	12530	Grill - Almond	2.0
WHFG17W13H	12523	Oversize Grill 13"H x 17"W	3.5

NOTE: This is the quickest option when the factory installed heaters options are not in stock.

Accessories

MODEL	UPC	DESCRIPTION	SHIP WEIGHT lbs
TKIT-1BW	20654	Built-in Single Pole Single Throw Thermostat Kit, Bright White	0.5
TKIT-2BW	20655	Built-in Double Pole Single Throw Thermostat Kit, Bright White	0.5
TKIT-1A	11058	Built-in Single Pole Single Throw Thermostat Kit, Almond	0.5
TKIT-2A	11059	Built-in Double Pole Single Throw Thermostat Kit, Almond	0.5

Engineering Specifications

Contractor shall supply and install WHF Series in-wall mounted forced-air electric heaters manufactured by King Electrical Mfg. Company. Heaters shall be of the wattage and voltage as indicated on the plans.

Ratings: Heaters shall be available in wattages of 500 to 2,000 at 120, 208, or 240 Volts

Blower and Motor: A whisper quiet tangential blower, delivering 75 CFM, shall be driven by a shaded pole, permanently lubricated, C-frame type motor with impedance protection and sealed bearings. Motors shall be the same voltage as the heater. The motor and all wiring shall be totally isolated from the heating chamber for protection from heated air.

Thermal Overload: Heaters shall be equipped with King's patented thermal overload Smart Limit ProtectionSM, which disconnects elements and motor in the event normal operating temperatures are exceeded. If thermal overload trips due to abnormal operating temperatures, thermal overload shall remain open until manually reset by turning the heater off for 15 minutes. Automatic reset of thermal overloads, which allow the element to continue to cycle under abnormal conditions, will not be accepted.

Elements: Element assemblies shall be constructed of coiled nickel chromium alloy, corrosion resistant wire strung through a minimum of four rows of mica insulator. Element assemblies shall have factory provided connection to allow field modification to 50% wattage at time of installation.

Wall Can: The wall can shall be 20 gauge electro-galvanized steel and shall contain knockouts. The wall can shall be provided with a depth gauge, extending the full length of the wall can. The wall can shall be supplied with a factory installed ground-wire. Minimum clearance 4" to floors and 6" to sidewalls. Zero clearance to combustibles material in the wall.

Grill: The grill shall be a louvered, one-piece design with rounded edges on all four sides, with rounded corners to prevent snags from contact with other materials. The grill shall be epoxy powder-coated in the color specified by the manufacturer

Approvals: cULus (E41422)

Dimensional Data

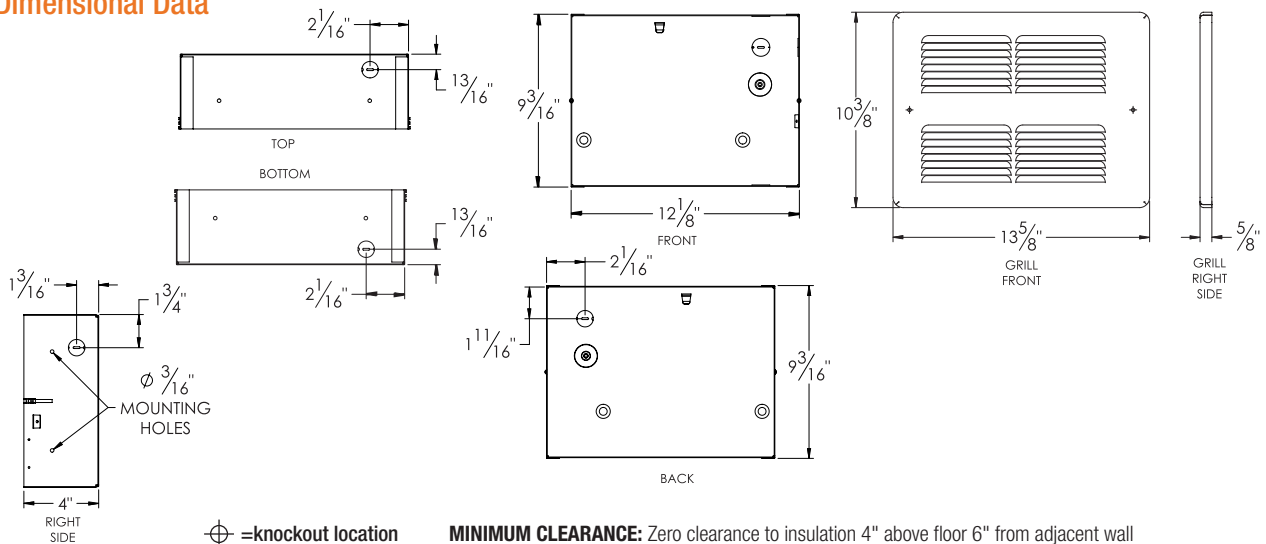

Wall Heater PAW Series

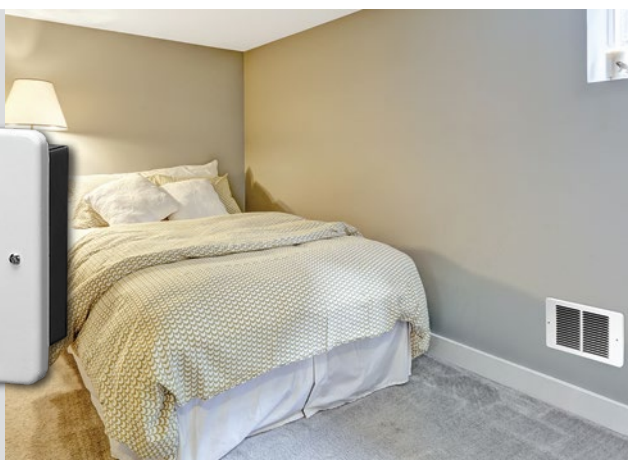
Model Code:
PAW 12 15 -I -RF
A B C D E

A: Series
 B: 12 - 120V 24 - 240V
 20 - 208V 27 - 277V
 C: Watts (250 to 2250)
 D: Interior & Grill
 E: Right Hand Feed

Pic-A-Watt
Steel Fin Element

- Pic-A-Watt® element
- Squirrel cage blower
- C-Frame motor
- Patented Smart Limit Protection®
- Whisper quiet
- Multiple wattages 250-2250
- 20 gauge powder-coated grill
- Wall can with QuickSet™ stud alignment tabs
- Standard color: white (almond color optional)
- 120, 208, 240, or 277 volts
- 5 Year warranty



The PAW Series

The Original Multi-Watt steel fin heater and our most popular heater for single family residences and upscale condominiums. King's exclusive Pic-A-Watt steel fin element allows customers to select from a range of wattage options, tailoring the heater to an area's specific heating requirements. Perfect for large living areas yet whisper quiet enough for bedrooms. The premium combination of an efficient high-mass steel element and whisper quiet squirrel cage blower, offers top of the class performance and years of trouble-free operation. PAW comes with five year warranty and 20+ year history of reliability. For best results use with an electronic line voltage wall thermostat. Also available is a built-in thermostat kit. The wall can shall be 20 gauge electro-galvanized steel and contain knockouts through which power leads are brought. The wall can shall be able to mount directly to wall studs in new or existing construction. The wall can shall be provided with QuickSet™ stud alignment tabs, used for maintaining proper depth during new installation. The wall can shall be supplied with a factory installed ground wire. Clearance: 6" to a side all, 4" from floor minimum.

Ordering Information *Add suffix -W for White Grill or -A for Almond Grill

BASE MODEL	VOLTS	WATTS	AMPS	SHIP WEIGHT lbs
PAW1215	120	250 • 500 • 750 • 1000 • 1250 • 1500	2.1 - 12.5	9.5
PAW2022	208	500 • 750 • 1000 • 1250 • 1500 • 1750 • 2250	2.4 - 10.8	9.5
PAW2422	240	500 • 750 • 1000 • 1250 • 1500 • 1750 • 2250	2.1 - 9.4	9.5
PAW2720	277	1000 • 2000	3.6 - 7.2	9.5

Factory Installed Options

ADD SUFFIX	DESCRIPTION	SHIP WEIGHT lbs
-W	White Color	
-A	Almond Color	
-SS	Stainless Steel Grill	9.6
-H	Interior Only (no can or grill)	7.5
-I	Interior and Grill Only (no wall can)	7.5
-DS15	Factory Installed Double Pole Disconnect (10A/ 240V / 15A/120V)	8.0

NOTE: Not all configurations listed above are stock items (A+ or A stock code). Refer to price book for the Stock code. For non-stock items refer to the table below to order heater parts separately.

Order A'la Carte Follow steps 1, 2 and 3 below to order a heater from separate parts.

STEP 1: Order Heatbox Interior

ADD SUFFIX	DESCRIPTION	SHIP WEIGHT lbs
-I	Heatbox Interior and Grill	7
-H	Heatbox Interior	7

STEP 2: Order Wall Can

MODEL	UPC	DESCRIPTION	SHIP WEIGHT lbs
PAWIC	00515	Recess Wall Can	2.5
PAWIC-RF	14033	Recess Wall Can - Right Hand Feed	2.5
PAWF	16319	Recess Can with Flange (remodel)	2.0
PAWS-W	16305	PIC-A-WATT® Surface Can - White - 13.5" L x 4.5" W x 7.5" H	5.5
PAWS-A	19298	PIC-A-WATT® Surface Can - Almond - 13.5" L x 4.5" W x 7.5" H	5.5
PAWS-SS	16317	PIC-A-WATT® Surface Can - Stainless Steel- 13.5" L x 4.5" W x 7.5" H	5.5

STEP 3: Order Grill (not required for -I models)

MODEL	UPC	DESCRIPTION	SHIP WEIGHT lbs
PAWG-W	16304	Grill - White	1.0
PAWG-ALMOND	16335	Grill - Almond	1.0
PAWG-SS	16330	Grill - Stainless Steel	1.0
PAWOG-A	00555	13" H x 13.5" W x .5" D Retrofit Grill	3.0
PAWOG-B	00560	8.5" H x 17" W x .5" D Retrofit Grill	3.0

NOTE: This is the quickest option when the factory installed heaters options are not in stock.

Accessories

MODEL	UPC	DESCRIPTION	SHIP WEIGHT lbs
TKIT-1BW	20654	Built-in Single Pole Single Throw Thermostat Kit, Bright White	0.5
TKIT-2BW	20655	Built-in Double Pole Single Throw Thermostat Kit, Bright White	0.5
TKIT-1A	11058	Built-in Single Pole Single Throw Thermostat Kit, Almond	0.5
TKIT-2A	11059	Built-in Double Pole Single Throw Thermostat Kit, Almond	0.5
PAW-GUARD	16550	PAW Accessory Wire Guard	2.0

Engineering Specifications

Contractor shall supply and install PAW Series in-wall forced-air electric heaters manufactured by King Electrical Mfg. Company, of the wattage and voltage as indicated on the plans.

Ratings: Heaters shall be available in wattages of 250 to 2,250 at 120, 208, 240, or 277 Volts.

Blower and Motor: A whisper quiet tangential blower, delivering 75 CFM, shall be driven by a shaded pole, permanently lubricated, C-frame type motor with impedance protection and sealed bearings. Motors shall be the same voltage as the heater.

Elements: Element assemblies shall consist of three steel sheathed heating tubes in a furnace-brazed, plate-finned, block design. Each sheathed tube shall contain coiled Ni-Chrome wire embedded in an insulator of Magnesium Oxide. The element assembly shall provide up to seven (7) possible wattage configurations available for selection during field installation. The use of external resistors, diodes, or other weak links to obtain multiple wattages will not be acceptable.

Thermal Overload: Heaters shall be equipped with King's patented thermal overload Smart Limit Protection®, which disconnects elements

and motor in the event normal operating temperatures are exceeded. If thermal overload trips due to abnormal operating temperatures, thermal overload shall remain open until manually reset by turning the heater off for 15 minutes. Automatic reset of thermal overloads, which allow the element to continue to cycle under abnormal conditions, will not be accepted.

Grill: The grill shall be a louvered, one-piece design with rounded edges on all four sides, with rounded corners to prevent snags from contact with other materials. The grill shall be epoxy powder-coated in white or almond.

Wall Can: The wall can shall be 20 gauge electro-galvanized steel and shall contain a minimum of three (3) knockouts. The wall can shall have a depth gauge indicator, and a factory installed, insulated and stranded copper ground-wire. Minimum 4" clearance to floors and 6" sidewalls. Zero clearance to combustibles in the wall.

Approvals: cULus (E41422)

Dimensional Data

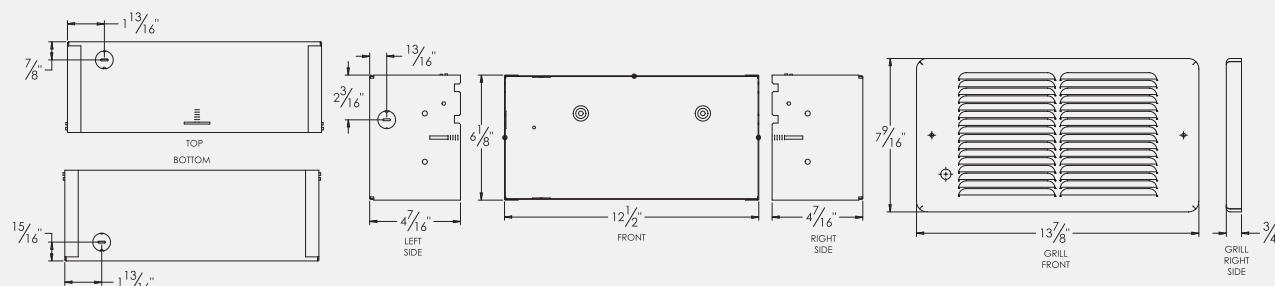

Options & Accessories

Exploded view



PAWS

Surface Wall Enclosure



PAWG-SS

Stainless Steel

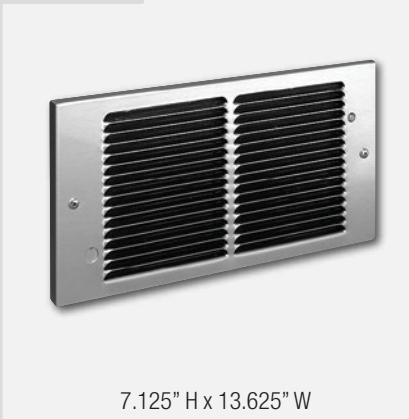

PAWOG-A

Oversize Grill



PAWOG-B

Oversize Grill

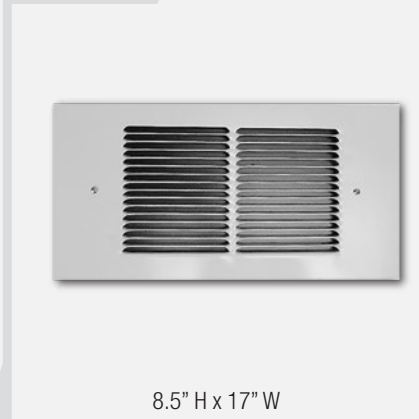

TKIT Thermostat For Wall Heaters



DS15

Double Pole Disconnect





Model Code:

PAW	12	15	-U
A	B	C	D
A: Series			
B: 12 - 120V 24 - 240V 20 - 208V 27 - 277V			
C: Watts (250 to 2250)			
D: ULTRA Grill			



- Ultra grill
- Patented Smart Limit Protection®
- Standard color: white
- Pic-A-Watt® element
- Whisper quiet
- (optional almond color available)
- Squirrel cage blower
- Multiple wattages 250-2250
- 120, 208, 240, 277 volts
- C-Frame motor
- 16 gauge powder-coated grill
- 5 Year warranty

The PAW Ultra Series

Make a bold statement with the PAW ULTRA series heater. Adding modern sophistication to our original Pic-A-Watt multi-watt steel fin heater with its sleek modern grill design, the ULTRA is ideal for upscale condominiums and luxury residences. King's exclusive Pic-A-Watt steel fin element allows customers to select from a range of wattage options, tailoring the heater to an area's specific heating requirements. Perfect for large living areas yet whisper quiet enough for bedrooms. The premium combination of an efficient high-mass steel element and whisper quiet squirrel cage blower, offers top of the class performance and years of trouble-free operation. PAW comes with five year warranty and 20+ year history of reliability. For use with an electronic line voltage wall thermostat.

Ordering Information *Add suffix -W for optional white color, -A for optional almond color

MODEL	UPC	VOLTS	WATTS	AMPS	SHIP WEIGHT lbs
PAW1215-U	18700	120	250•500•750•1000•1250•1500	2.1-12.5	9.5
PAW2022-U	18710	208	500•750•1000•1250•1500•1750•2250	2.4-10.8	9.5
PAW2422-U	18720	240	500•750•1000•1250•1500•1750•2250	2.1-9.4	9.5
PAW2720-U	22241	277	1000•2000	3.6-7.2	9.5

*See PAW Series page for dimensional data

Engineering Specifications

Contractor shall supply and install PAW Ultra Series in-wall forced-air electric heaters manufactured by King Electrical Mfg. Company, of the wattage and voltage as indicated on the plans.

Ratings: Heaters shall be available in wattages of 250 to 2,250 at 120, 208, 240, or 277 Volts.

Blower and Motor: A whisper quiet tangential blower, delivering 75 CFM, shall be driven by a shaded pole, permanently lubricated, C-frame type motor with impedance protection and sealed bearings. Motors shall be the same voltage as the heater.

Elements: Element assemblies shall consist of three steel sheathed heating tubes in a furnace-brazed, plate-finned, block design. Each sheathed tube shall contain coiled Ni-Chrome wire embedded in an insulator of Magnesium Oxide. The element assembly shall provide up to seven (7) possible wattage configurations available for selection during field installation. The use of external resistors, diodes, or other weak links to obtain multiple wattages will not be acceptable.

Thermal Overload: Heaters shall be equipped with King's patented thermal overload Smart Limit Protection®, which disconnects elements

and motor in the event normal operating temperatures are exceeded.

If thermal overload trips due to abnormal operating temperatures, thermal overload shall remain open until manually reset by turning the heater off for 15 minutes. Automatic reset of thermal overloads, which allow the element to continue to cycle under abnormal conditions, will not be accepted.

Grill: The grill shall be a louvered with multiple linear steel bars secured to a steel back plate, with rounded sides to prevent snags with other materials. The grill shall be epoxy powder-coated in white or almond.

Wall Can: The wall can shall be 20 gauge electro-galvanized steel and shall contain a minimum of three (3) knockouts. The wall can shall have a depth gauge indicator, and a factory installed, insulated and stranded copper ground-wire. Minimum 4" clearance to floors and 6" sidewalls. Zero clearance to combustibles in the wall.

Approvals: cULus (E41422)

Wall Heater PX ComfortCraft Series



Model Code:

PX 24 17 -WD -R
A B C D E

A: Series
B: 12 - 120V 20 - 208V 24 - 240V
**C: Watts 15-(750-1500W)
17-(750-1750W)**
D: Color
E: Color Box Packaging

ComfortCraft



Pic-A-Watt
Selectable Wattage Element



- Modern curved design
- Pic-A-Watt® element
- Multiple wattage options
- Whisper quiet blower design
- Zonal heating systems save money
- C-Frame motor
- Patented Smart Limit Protection®
- 20 gauge powder-coated grill
- Standard color: white dove
- Designer colors available
- 120, 208, 240 volts
- 5 Year limited warranty



The PX ComfortCraft Series Wall Heater

King refines comfort with the modern architectural design of the PX ComfortCraft series wall heater. The PX series heater delivers nearly 100% efficient electric heat, perfect for large living areas yet whisper quiet enough for bedrooms. The premium combination of an efficient high-mass steel element and whisper quiet squirrel cage blower, offers top of the class performance and years of trouble-free operation. PX comes with five year warranty and 30+ year history of reliability. For best results use with an electronic line voltage wall thermostat. Also available with a built-in thermostat. King's exclusive Pic-A-Watt® heating element allows customers to select from a range of wattage options, tailoring the heater to a room's specific heating requirements. For smaller areas, choose a lower wattage to efficiently heat the room. For larger rooms, choose a higher wattage and maximize comfort. It's as easy as unplugging a wire to select the wattage during installation. Now That's Smart!

DESIGNER COLORS AVAILABLE



"Complete" Stock Models For other color grill options use "Order A'la Carte" chart below to build your own complete heater.

BASE MODEL	VOLTS	COLOR	WATTS	AMPS	SHIP WEIGHT lbs
PX1215-WD-R	120	White Dove	250•500•750•1000•1250•1500	2.1 - 12.5	12.5
PX1215-AD-R	120	Almondine	250•500•750•1000•1250•1500	2.1 - 12.5	12.5
PX1215-SN-R	120	Satin Nickel	250•500•750•1000•1250•1500	2.1 - 12.5	12.5
PX1215-OB-R	120	Oiled Bronze	250•500•750•1000•1250•1500	2.1 - 12.5	12.5
PX2017-WD-R	208	White Dove	250•500•750•1000•1250•1500 • 1750	1.2 - 8.4	12.5
PX2017-AD-R	208	Almondine	250•500•750•1000•1250•1500 • 1750	1.2 - 8.4	12.5
PX2017-SN-R	208	Satin Nickel	250•500•750•1000•1250•1500 • 1750	1.2 - 8.4	12.5
PX2017-OB-R	208	Oiled Bronze	250•500•750•1000•1250•1500 • 1750	1.2 - 8.4	12.5
PX2417-WD-R	240/208*	White Dove	250•500•750•1000•1250•1500 • 1750	1.1 - 7.3	12.5
PX2417-AD-R	240/208*	Almondine	250•500•750•1000•1250•1500 • 1750	1.1 - 7.3	12.5
PX2417-SN-R	240/208*	Satin Nickel	250•500•750•1000•1250•1500 • 1750	1.1 - 7.3	12.5
PX2417-OB-R	240/208*	Oiled Bronze	250•500•750•1000•1250•1500 • 1750	1.1 - 7.3	12.5

(-R) Full color consumer packaging

*Dual rated heaters will draw 13% less amps and 25% less wattage when operated at 208V.

NOTE: Not all configurations listed above are stock items (A+ or A stock code). Refer to price book for the Stock code. For non-stock items refer to the table below to order heater parts separately.

Wall Heater PX ComfortCraft Series

Order A'la Carte **To build your own "Complete" with designer grill options (not noted above) select HRC model of proper voltage and PXG grill model of proper color.

STEP 1: Order Heatbox Interior and Recessed Wall Can

ADD SUFFIX	UPC	DESCRIPTION	SHIP WEIGHT lbs
PX1215-HRC	32688	PX 120V, 1500W, Heatbox Interior & Recessed Wall Can	10.4
PX2017-HRC	32689	PX 208V, 1750W, Heatbox Interior & Recessed Wall Can	10.4
PX2417-HRC	32690	PX 240V, 1750W, Heatbox Interior & Recessed Wall Can	10.4

STEP 2: Order Grill

MODEL	UPC	DESCRIPTION	SHIP WEIGHT lbs
PXG-WD	17246	PX Grill, White Dove Color	2.1
PXG-AD	17247	PX Grill, Almondine Color	2.1
PXG-SN	17245	PX Grill, Satin Nickel Color	2.1
PXG-OB	17244	PX Grill, Oiled Bronze Color	2.1

NOTE: This is the quickest option when the factory installed heaters options are not in stock.

Accessories

MODEL	UPC	DESCRIPTION	SHIP WEIGHT lbs
PXSMF-WD	32695	PX Surface Mount Frame, White Dove Color (H 8-3/4 x W 16-15/16 x D 4-1/4)	2.4
PXSMF-AD	32696	PX Surface Mount Frame, Almondine Dove Color (H 8-3/4 x W 16-15/16 x D 4-1/4)	2.4
PXSMF-SN	32697	PX, Surface Mount Frame, Satin Nickel Color	2.4
PXSMF-OB	32698	PX, Surface Mount Frame, Oiled Bronze Color	2.4
PX-RP	32699	PX, Rough In Plate - For New Construction	0.5
PXIC	32704	PX Wall Can	3.0
TKIT-1BL	17346	Wall Heater Accessory SP Thermostat Kit Black	0.5
TKIT-2BL	17347	Wall Heater Accessory DP Thermostat Kit Black	0.5

** Kraft box packaging

Engineering Specifications

Contractor shall supply and install PX ComfortCraft Series in-wall forced-air electric heaters manufactured by King Electrical Mfg. Company, of the wattage and voltage as indicated on the plans.

Ratings: Heaters shall be available in wattages of 250 to 1,500 at 120 or 250-1750 at 208, or 240 Volts.

Blower and Motor: A whisper quiet tangential blower, delivering 75 CFM, shall be driven by a shaded pole, permanently lubricated, C-frame type motor with impedance protection and sealed bearings. Motors shall be the same voltage as the heater.

Elements: Element assemblies shall consist of three steel sheathed heating tubes in a furnace-brazed, plate-finned, block design. Each sheathed tube shall contain coiled Ni-Chrome wire embedded in an insulator of Magnesium Oxide. The element assembly shall provide up to seven (7) possible wattage configurations available for selection during field installation. The use of external resistors, diodes, or other weak links to obtain multiple wattages will not be acceptable.

Thermal Overload: Heaters shall be equipped with King's patented

thermal overload Smart Limit Protection®, which disconnects elements and motor in the event normal operating temperatures are exceeded.

If thermal overload trips due to abnormal operating temperatures, thermal overload shall remain open until manually reset by turning the heater off for 15 minutes. Automatic reset of thermal overloads, which allow the element to continue to cycle under abnormal conditions, will not be accepted.

Wall Cans: The wall can shall be 20 gauge electro-galvanized steel and shall contain a minimum of three (3) knockouts. The wall can shall have a factory installed, insulated and stranded copper ground-wire. Minimum 4" clearance to floors and 6" sidewalls. Zero clearance to combustibles.

Grill: The grill shall be a louvered, one-piece curved front design with rounded edges on all four sides, with duct flange on outlet to achieve maximum heat transfer. The grill shall be epoxy powder-coated in white dove, almondine, oiled bronze or satin nickel.

Approvals: cULus (E41422)

Dimensional Data

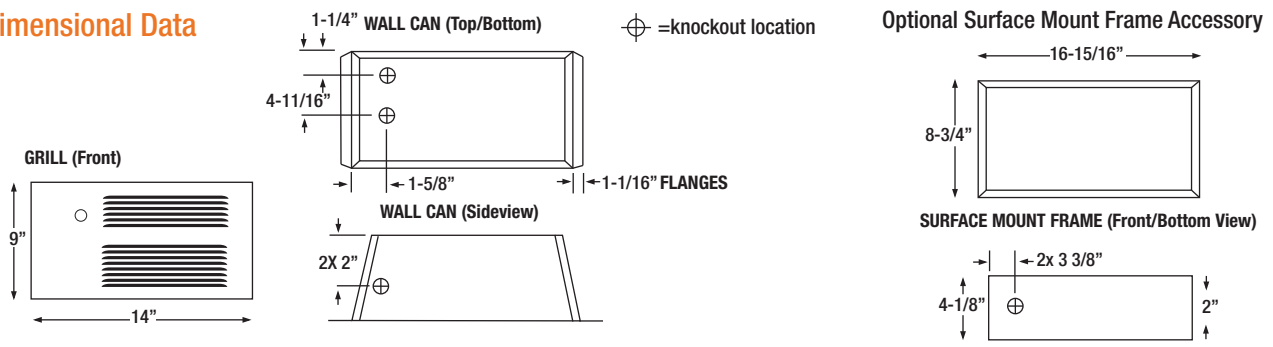

Electronic Wall Heater PX ECO2S Series Pic-A-Watt Selectable Wattage Element

Model Code:
PX 24 17 -ECO -WD
A B C D E
A: Series
B: 12 - 120V 20 - 208V 24 - 240V
C: Watts 15-(750-1500W)
17-(750-1750W)
D: ECO2S Controller
E: Color Grill
F: Color Box Packaging

- Modern curved design
- ECO2S electronic controller
- Energy efficient 2-stage heating
- Fan only & timer modes
- Remote control included
- Pic-A-Watt® element
- Multiple wattage options
- Whisper quiet blower design
- C-Frame motor
- Patented Smart Limit Protection®
- Standard color: white dove
- Designer colors available
- 120, 208, 240 volts
- 5 Year limited warranty



The PX Series Wall Heater

King redefines comfort with the energy saving smart series ECO2S Wall heater. Combining a sleek and modern design with unparalleled performance, energy efficiency and user control. The ECO2S controller ensures consistent comfort by minimizing temperature swings. In a cold room it utilizes full power to heat the room quickly. Once the desired temperature is achieved, the heater automatically reduces the wattage to maintain the room temperature and save energy. Includes both summer fan only and timer mode options, as well as a remote control for simple operation. In addition, King's exclusive Pic-A-Watt® selectable wattage element allows customers to select from a range of wattage options, tailoring the heater to a room's specific heating requirements. It's as easy as unplugging a wire to select the maximum wattage during installation. Now That's Smart!

DESIGNER COLORS AVAILABLE

"Complete" Stock Models For other color grill options use "Order A'la Carte" chart below to build your own complete heater.

BASE MODEL	VOLTS	COLOR	WATTS	AMPS	SHIP WEIGHT lbs
PX1215-ECO-WD-R	120	White Dove	750•1000•1250•1500	6.25 - 12.5	12.5
PX1215-ECO-AD-R	120	Almondine	750•1000•1250•1500	6.25 - 12.5	12.5
PX1215-ECO-SN-R	120	Satin Nickel	750•1000•1250•1500	6.25 - 12.5	12.5
PX1215-ECO-OB-R	120	Oiled Bronze	750•1000•1250•1500	6.25 - 12.5	12.5
PX2017-ECO-WD-R	208	White Dove	750•1250•1500•1000 • 1750	3.6 - 8.4	12.5
PX2017-ECO-AD-R	208	Almondine	750•1250•1500•1000 • 1750	3.6 - 8.4	12.5
PX2017-ECO-SN-R	208	Satin Nickel	750•1250•1500•1000 • 1750	3.6 - 8.4	12.5
PX2017-ECO-OB-R	208	Oiled Bronze	750•1250•1500•1000 • 1750	3.6 - 8.4	12.5
PX2417-ECO-WD-R	240/208*	White Dove	750•1250•1500•1000 • 1750	3.1 - 7.3	12.5
PX2417-ECO-AD-R	240/208*	Almondine	750•1250•1500•1000 • 1750	3.1 - 7.3	12.5
PX2417-ECO-SN-R	240/208*	Satin Nickel	750•1250•1500•1000 • 1750	3.1 - 7.3	12.5
PX2417-ECO-OB-R	240/208*	Oiled Bronze	750•1250•1500•1000 • 1750	3.1 - 7.3	12.5

(-R) Full color consumer packaging

*Dual rated heaters will draw 13% less amps and 25% less wattage when operated at 208V.

NOTE: Not all configurations listed above are stock items (A+ or A stock code). Refer to price book for the Stock code. For non-stock items refer to the table below to order heater parts separately.

Electronic Wall Heater PX ECO2S Series

Order A'la Carte **To build your own "Complete" with designer grill options (not noted above) select HRC model of proper voltage and PXG-ECO grill model of proper color.

STEP 1: Order Heatbox Interior and Recessed Wall Can

ADD SUFFIX	UPC	DESCRIPTION	SHIP WEIGHT lbs
PX1215-ECO-HRC	32692	PX ECO, 120V 1500W, Heatbox Interior & Recessed Wall Can	10.4
PX2017-ECO-HRC	32693	PX ECO, 208V 1750W, Heatbox Interior & Recessed Wall Can	10.4
PX2417-ECO-HRC	32694	PX ECO, 240V 1750W, Heatbox Interior & Recessed Wall Can	10.4

STEP 2: Order Grill

MODEL	UPC	DESCRIPTION	SHIP WEIGHT lbs
PXG-ECO-WD	17242	PX ECO, Grill, White Dove Color	2.1
PXG-ECO-AD	17243	PX ECO, Grill, Almondine Color	2.1
PXG-ECO-SN	17241	PX ECO, Grill, Satin Nickel Color	2.1
PXG-ECO-OB	17240	PX ECO, Grill, Oiled Bronze Color	2.1

NOTE: This is the quickest option when the factory installed heaters options are not in stock.

Accessories

MODEL	UPC	DESCRIPTION	SHIP WEIGHT lbs
PXSMF-WD	32695	PX ECO, Surface Mount Frame, White Dove Color	2.4
PXSMF-AD	32696	PX ECO, Surface Mount Frame, Almondine Color	2.4
PXSMF-SN	32697	PX ECO, Surface Mount Frame, Satin Nickel Color	2.4
PXSMF-OB	32698	PX ECO, Surface Mount Frame, Oiled bronze Color	2.4
PX-RP	32699	PX ECO, Surface Mount Frame, Oiled bronze Color	0.5
PXIC	32704	PX ECO, Wall Can	3.0
61747	61747	PX ECO Replacement Infrared Remote Control	0.125

** Kraft box packaging

Engineering Specifications

Contractor shall supply and install PX ECO2S Series electronic in-wall forced-air electric heaters manufactured by King Electrical Mfg. Company, of the wattage and voltage as indicated on the plans.

Ratings: Heaters shall be available in wattages of 750 to 1,500 at 120 or 750-1750 at 208, or 240 Volts.

ECO2S Electronic Control: Up, Down temperature mode. Automatic 2-Stage heating (High & ECO Modes). Start/Stop. Fan Only and Timer (1-9hours) Modes. Standard on all heaters. The control voltage is equal to the line voltage.

Blower and Motor: A whisper quiet tangential blower, delivering 75 CFM, shall be driven by a shaded pole, permanently lubricated, C-frame type motor with impedance protection and sealed bearings. Motors shall be the same voltage as the heater.

Elements: Element assemblies shall consist of three steel sheathed heating tubes in a furnace-brazed, plate-finned, block design. Each sheathed tube shall contain coiled Ni-Chrome wire embedded in an insulator of Magnesium Oxide. The element assembly shall provide up to seven (7) possible wattage configurations available for selection during field installation. The use of external resistors, diodes, or other weak links to obtain multiple wattages will not be acceptable.

Thermal Overload: Heaters shall be equipped with King's patented thermal overload Smart Limit Protection®, which disconnects the elements and motor in the event normal operating temperatures are exceeded. If thermal overload trips due to abnormal operating temperatures, thermal overload shall remain open until manually reset by turning the heater off for 15 minutes. Automatic reset of thermal overloads, which allow the element to continue to cycle under abnormal conditions, will not be accepted.

Grill: The grill shall be a louvered, one-piece curved front design with rounded edges on all four sides, with duct flange outlet to achieve maximum heat transfer. The grill shall be epoxy powder-coated in white dove, almondine, satin nickel or oiled bronze.

Wall Can: The wall can shall be 20 gauge electro-galvanized steel and shall contain a minimum of three (3) knockouts. The wall can shall have a factory installed, insulated and stranded copper ground-wire. Minimum 4" clearance to floors and 6" sidewalls. Zero clearance to combustibles in the wall.

Approvals: cULus (E41422)

Dimensional Data

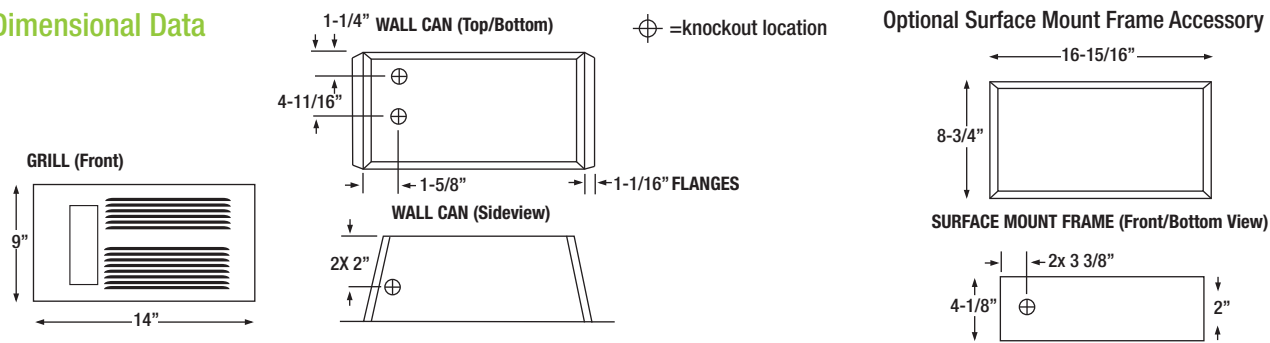

High Wall Heater WHF-HM Series



Model Code:

WHF-HM	12	10	-A
A	B	C	D
A: Series			
B: 12 - 120V 24 - 240V			
20 - 208V			
C: Watts (500 to 2000)			
D: Color			



- Mounts 6 feet above the floor
- Squirrel Cage Blower
- Whisper Quiet
- Ni-chrome Open-Coil Element
- Patented Smart Limit Protection*
- 20 gauge powder-coated grill
- Standard color: white
- C-Frame Motor
- 20 gauge electrogalvanized steel recess can with
- Wall can with QuickSet™ stud alignment tabs
- 120, 208, or 240 volts
- Dual Wattage
- 1 Year Warranty

The WHF-HM Wall Heater

The WHF-HM High Mount heater is designed for applications to be mounted 6' above the floor. It is commonly used where wall space is limited. The high wall mounting allows you to use absolutely any wall in a room without affecting the furniture or decor placement. The WHF-HM provides extreme value by combining an open coil Ni-chrome wire element and squirrel cage blower. For maximum comfort and efficiency, an electronic wall thermostat is recommended. The wall can shall be 20 gauge electro-galvanized steel and contain knockouts through which power leads are brought. The wall can shall be able to mount directly to wall studs in new or existing construction. The wall can shall be provided with QuickSet™ stud alignment tabs, used for maintaining proper depth during new installation. The wall can shall be supplied with a factory installed ground wire. Clearance: 6" to a side all, 4" from floor minimum, 12" from ceiling minimum.

Ordering Information *Add suffix -W for White Grill or -A for Almond Grill

	BASE MODEL	VOLTS	WATTS	AMPS	SHIP WEIGHT lbs
120V	WHF1210-HM	120	500 • 1000	4.2 - 8.4	8.0
	WHF1212-HM	120	600 • 1200	5.0 - 10.0	8.0
	WHF1215-HM	120	750 • 1500	6.3 - 12.5	8.0
208V	WHF2010-HM	208	500 • 1000	2.4 - 4.8	8.0
	WHF2015-HM	208	750 • 1500	3.6 - 7.2	8.0
	WHF2020-HM	208	1000 • 2000	4.8 - 9.6	8.0
240V	WHF2410-HM	240	500 • 1000	2.1 - 4.2	8.0
	WHF2412-HM	240	600 • 1200	2.5 - 5.0	8.0
	WHF2415-HM	240	750 • 1500	3.1 - 6.2	8.0
	WHF2420-HM	240	1000 • 2000	4.2 - 8.4	8.0

Factory Installed Options

ADD SUFFIX	DESCRIPTION	SHIP WEIGHT lbs
-W	White Color	8.0
-A	Almond Color	8.0
-H	Heatbox Interior Only (no can or grill)	3.5
-I	Heatbox Interior and Grill Only (no wall can)	5.5
-DS15	Factory Installed Double Pole Disconnect (10A/ 240V / 15A/120V)	8.0

NOTE: Not all configurations listed above are stock items (A+ or A stock code). Refer to price book for the Stock code. For non-stock items refer to the table below to order heater parts separately.

Order A'la Carte Follow steps 1, 2 and 3 below to order a heater from separate parts.

STEP 1: Order Heatbox Interior

ADD SUFFIX	DESCRIPTION	SHIP WEIGHT lbs
-H	Heatbox Interior Only (no can or grill)	3.5
-I	Heatbox Interior and Grill Only (no wall can)	5.5

High Wall Heater WHF-HM Series

STEP 2: Order Wall Can

MODEL	UPC	DESCRIPTION	SHIP WEIGHT lbs
UIC	12640	Recess Wall Can	3.5
UICF	12540	Recess Can with Flange (remodel)	4.0
WHSC-W	19204	Surface Can - White - 13.5" H x 10.125" W x 4" D	4.0
WHSC-A	19205	Surface Can - Almond - 13.5" H x 10.125" W x 4" D	4.0

STEP 3: Order Grill (not required for -I models)

MODEL	UPC	DESCRIPTION	SHIP WEIGHT lbs
WHFG-W	12020	WHF ACCY GRILL FOR HIGH MOUNT HEATER WHITE	2.0

NOTE: This is the quickest option when the factory installed heaters options are not in stock.

Accessories

MODEL	UPC	DESCRIPTION	SHIP WEIGHT lbs
TKIT-1BW	20654	Built-in Single Pole Single Throw Thermostat Kit, Bright White	0.5
TKIT-2BW	20655	Built-in Double Pole Single Throw Thermostat Kit, Bright White	0.5
TKIT-1A	11058	Built-in Single Pole Single Throw Thermostat Kit, Almond	0.5
TKIT-2A	11059	Built-in Double Pole Single Throw Thermostat Kit, Almond	0.5

Engineering Specifications

Contractor shall supply and install WHF-HM Series in-wall mounted forced-air electric heaters manufactured by King Electrical Mfg. Company. Heaters shall be of the wattage and voltage as indicated on the plans.

Ratings: Heaters shall be available in wattages of 500 to 2,000 at 120, 208, or 240 Volts

Blower and Motor: A whisper quiet tangential blower, delivering 75 CFM, shall be driven by a shaded pole, permanently lubricated, C-frame type motor with impedance protection and sealed bearings. Motors shall be the same voltage as the heater. The motor and all wiring shall be totally isolated from the heating chamber for protection from heated air.

Thermal Overload: Heaters shall be equipped with King's patented thermal overload Smart Limit ProtectionSM, which disconnects elements and motor in the event normal operating temperatures are exceeded. If thermal overload trips due to abnormal operating temperatures, thermal overload shall remain open until manually reset by turning the heater off for 15 minutes. Automatic reset of thermal overloads, which allow the element to continue to cycle under abnormal conditions, will not be accepted.

Elements: Element assemblies shall be constructed of coiled nickel chromium alloy, corrosion resistant wire strung through a minimum of four rows of mica insulator. Element assemblies shall have factory provided connection to allow field modification to 50% wattage at time of installation.

Wall Can: The wall can shall be 20 gauge electrogalvanized steel and shall contain knockouts. The wall can shall be provided with a depth gauge, extending the full length of the wall can. The wall can shall be supplied with a factory installed groundwire. Minimum clearance 72" to floors, 6" to sidewalls, and 4" to the ceiling. Zero clearance to down flow.

Grill: The grill shall be a louvered, one-piece design with rounded edges on all four sides, with rounded corners to prevent snags from contact with other materials. The grill shall be epoxy powder-coated in the color specified by the manufacturer

Approvals: cULus (E41422)

Dimensional Data

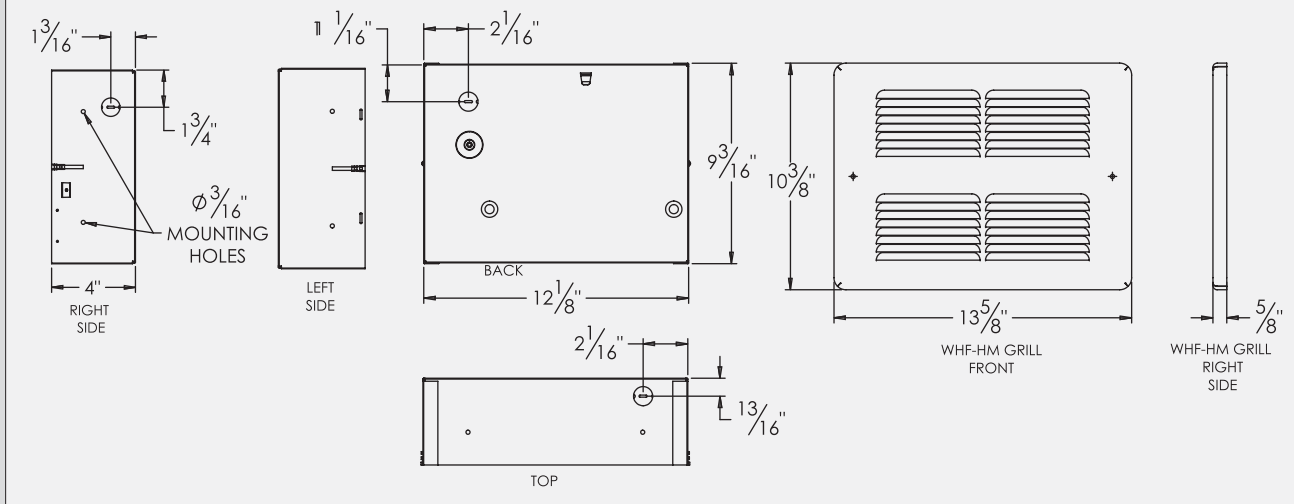

Surface Mount Heater SL Series



Model Code:

SL	12	15
A	B	C

A: Series
B: 12 - 120V 24 - 240V
20 - 208V
C: Watts (250 to 2250)



- Baseboard replacement
- Zero clearance to the floor
- Multiple wattages
- Standard color: bright white
- Whisper quiet
- C-Frame motor
- Surface mount
- 120, 208 or 240 volts
- Pic-A-Watt® element
- Patented Smart Limit Protection®
- 20 Gauge powder coated grill
- 5-year limited warranty
- Squirrel cage blower



The SL - Surface Mount Wall Heater

The Slim Line heater was specifically designed as a space-saving replacement for baseboard heaters, allowing you to reclaim up to 8 linear feet of valuable wall space. The unique slim surface-mounted wall can allows the heater to be mounted directly in contact with the finished floor (unlike other fan heaters that require to be installed at least 4" above the floor). The Pic-A-Watt® feature allows a customers to select from a range of wattage options, tailoring the heater to an area's specific heating requirements. Baseboard conversion made simple. 2 foot baseboard = 500W; 3 feet = 750W; 4 feet = 1000W; 5 feet = 1250W; 6 feet = 1500W; 8 feet = 1750W; 10 feet = 2250W. Same quiet and reliable design as the original PAW heater but in an easy-to install surface mounted package. For use with a field installed wall thermostat or field installed in-built thermostat.

Ordering Information

MODEL	UPC	VOLTS	WATTS	AMPS	SHIP WEIGHT lbs
SL1215	19550	120	250•500•750•1000•1250•1500	2.1-12.6	11
SL2022	19555	208	500•750•1000•1250•1500•1750•2250	2.4-10.8	11
SL2422	19560	240	500•750•1000•1250•1500•1750•2250	2.1-9.4	11

Engineering Specifications

Contractor shall supply and install SL Series wall surface-mounted forced air electric heaters manufactured by King Electrical Mfg. Company of the wattage and voltage as indicated on the plans.

Ratings: Heaters shall be available in wattages of 250 to 2,250 at 120, 208 or 240 volts. The heater shall be approved for surface mounting with zero clearance from the floor.

Blower and Motor: A tangential cylindrical blower, delivering 75 CFM, shall be driven by a shaded pole, permanently lubricated, C-frame type motor with impedance protection and sealed bearings. Motors shall be the same voltage as the heater.

Elements: Element assemblies shall consist of three steel sheathed heating tubes in a furnace-brazed, plate-finned, block design. Each sheathed tube shall contain coiled Ni-Chrome wire, embedded in an insulator of Magnesium Oxide. The element assembly shall provide up to seven (7) possible wattage configurations available for selection during field installation. The use of external resistors, diodes, or other weak links to obtain multiple wattages will not be accepted.

Thermal Overload: Heaters shall be equipped with King's patented

thermal overload Smart Limit Protection®, which disconnects elements and motor in the event normal operating temperatures are exceeded. If thermal overload trips due to abnormal operating temperatures, thermal overload shall remain open until manually reset by turning the heater off for 15 minutes. Automatic reset of thermal overloads, which allow the element to continue to cycle under abnormal conditions, will not be accepted.

Surface Can: The surface can shall be 20 gauge electro-galvanized steel and shall contain a minimum of three (3) knockouts. The surface can shall be epoxy powder coated and contain a stranded ground-wire. Minimum clearance to floors is 0" and 6" to any sidewall.

Grill: The grill shall be a louvered, one-piece design with rounded edges on all four sides, with rounded corners to prevent snags from contact with other materials. The grill shall be epoxy powder-coated in the color specified on the plans.

Approvals: cULus (E41422)

Surface Mount Heater SL Series

Dimensional Data

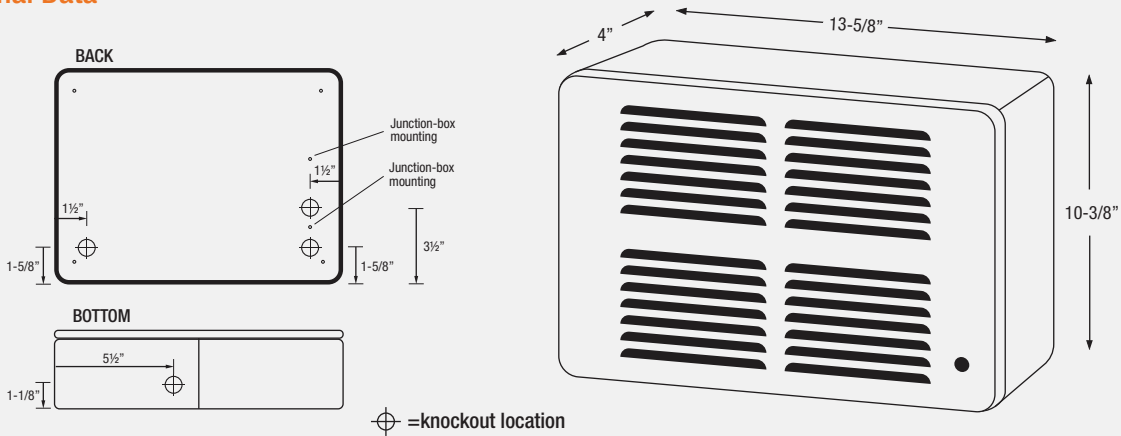

Factory Installed Options

ADD SUFFIX	DESCRIPTION	SHIP WEIGHT lbs
-DS15	Factory Installed Double Pole Disconnect (10A/ 240V / 15A/120V)	11

Accessories

MODEL	UPC	DESCRIPTION	WEIGHT lbs
SLT-1	19562	Single Pole Single Throw Thermostat Kit	0.5
SLT-2	19564	Double Pole Single Throw Thermostat Kit	0.5



Smart Heating Solutions

RECLAIM YOUR HOME



Standard Baseboard Heater



New Slimline Space Saving Heater

With the Slimline Fan Heater by

Multi-Watt Wall Heater EFW-MW Series



Model Code:

EFW-MW	24	40	-A	-I	-T
A	B	C	D	E	F

- A: Series
- B: 12 - 120V 24 - 240V
20 - 208V
- C: Watts (2000 to 4800)
- D: Color
- E: Interior & Grill
- F: Thermostat (optional)



- New multi-wattage design
- NiChrome open-coil element
- Cast aluminum motor
- 5-Blade aluminum fan
- Auto-Reset safety limit
- Standard color: white Optional: almond
- 20 gauge powder-coated grill
- Available in 120, 208, 240 volts
- 1-year limited warranty



The New EFW-MW Multi-Watt Wall Heater

The EFW-MW heater is designed to be a very affordable, large wattage wall heater. It is commonly used in apartment construction to heat rooms up to 400 square feet, or where a remote thermostat is required on a 4000 Watt-style heater. The NiChrome open-coil element dissipates heat quickly and offers multiple wattage options, tailoring the heater to a rooms' specific heating requirements. The 4-Pole cast aluminum unit bearing motor is permanently lubricated for years of trouble-free service. Intended to be used with wall mounted or built-in thermostat.

Ordering Information *Add suffix -W for White Grill or -A for Almond Grill

	MODEL	VOLTS	WATTS	AMPS	SHIP WEIGHT lbs
120V	EFW1230-MW	120	2000•3000	16.6/25	16.0
208V	EFW2040-MW	208	2000•3000•4000	9.6/14.4/19.2	16.0
240V	EFW2440-MW	240/208*	2000•3000•4000	8.3/12.5/16.6	16.0
	EFW2440-MW-T	240/208*	2000•3000•4000	8.3/12.5/16.6	16.0

*Dual rated heaters will draw 13% less amps and 25% less wattage when operated at 208V.

Factory Installed Options

ADD SUFFIX	DESCRIPTION	SHIP WEIGHT lbs
-W	White Color	
-A	Almond Color	
-HRC	Heatbox Interior & Recessed Wall Can	13.0

NOTE: Not all configurations listed above are stock items (A+ or A stock code). Refer to price book for the Stock code. For non-stock items refer to the table below to order heater parts separately.

Order A'la Carte **To build your own "Complete" with designer grill options (not noted above) select HRC model of proper voltage and EFWG grill model of proper color.

STEP 1: Order Heatbox Interior and Recessed Wall Can

ADD SUFFIX	UPC	DESCRIPTION	SHIP WEIGHT lbs
EFW1230-MW-HRC	67086	EFW Heatbox Interior & Recessed Wall Can Only 120V 3000W	13.0
EFW2040-MW-HRC	67087	EFW Heatbox Interior & Recessed Wall Can Only 208V 4000W	13.0
EFW2440-MW-HRC	67088	EFW Heatbox Interior & Recessed Wall Can Only 240V 4000W	13.0

STEP 2: Order Grill

MODEL	UPC	DESCRIPTION	SHIP WEIGHT lbs
EFWG-W	19439	Grill - White	3.0
EFWG-A	19440	Grill - Almond	3.0
EFWOG-W	19442	21¾" H x 15½" W Oversize Grill - White	4.0
EFWOG-A	19441	21¾" H x 15½" W Oversize Grill - Almond	4.0
EFWOG-XL-W	19443	21¾" H x 16½" W Oversize Grill	6.5

Multi-Watt Wall Heater EFW-MW Series

Accessories

MODEL	UPC	DESCRIPTION	SHIP WEIGHT lbs
UWIC	12590	Recessed Wall Can	6.5
UWSA	12599	Surface Can - White 3¾" Deep	7.5
UWSA-A	12595	Surface Can - Almond	7.5
EFT-1	19445	Single Pole 22 Amp Thermostat Kit	0.5
EFT-2	19448	Double Pole 22 Amp Thermostat Kit	0.5
LPW-TPC	18174	Tamper-proof Cover for Controls 3¼" x 3¼" x 18¾"	1.5
EFT-1-TP	19480	Tamper-proof Integral Stat Kit	0.5

Engineering Specifications

Contractor shall supply and install EFW-MW Series in-wall mounted forced-air electric heaters manufactured by King Electrical Mfg. Company. Heaters shall be of the wattage and voltage as indicated on the plans.

Motor: Heavy-duty cast aluminum 4 pole unit bearing, permanently lubricated with 10cc oil reservoir, 1440 RPM. Enclosed impedance protected with intake air cooling motor for increased bearing life.

Fan: High efficiency, dynamically balanced 5-blade aluminum fan. 185 CFM.

Multi-Wattage Elements: Element assemblies shall be constructed of coiled Nickel Chromium alloy, corrosion-resistant wire strung through a minimum of four rows of mica insulator. Element assemblies shall have factory provided connection to allow field modification to select from available wattages.

Auto Reset Safety Limit: The thermal cutout turns off power to the heater in the event of overheating and automatically resets when temperature returns to normal.

Wall-box: 20 gauge electro-galvanized steel with factory installed ground-wire. Minimum 4" clearance to floors and 6" to sidewalls. Zero clearance to insulation in the wall. Recommended 10" clearance to floors and 16" to sidewalls.

Grill: 20 gauge steel finished in a gloss white, powder-coated paint. Optional Almond color.

Options: 1-Pole or 2-Pole built-in thermostat 45-80°F operating range, retrofit grill, and surface wall-box.

Approvals: cCSAus

Dimensional Data

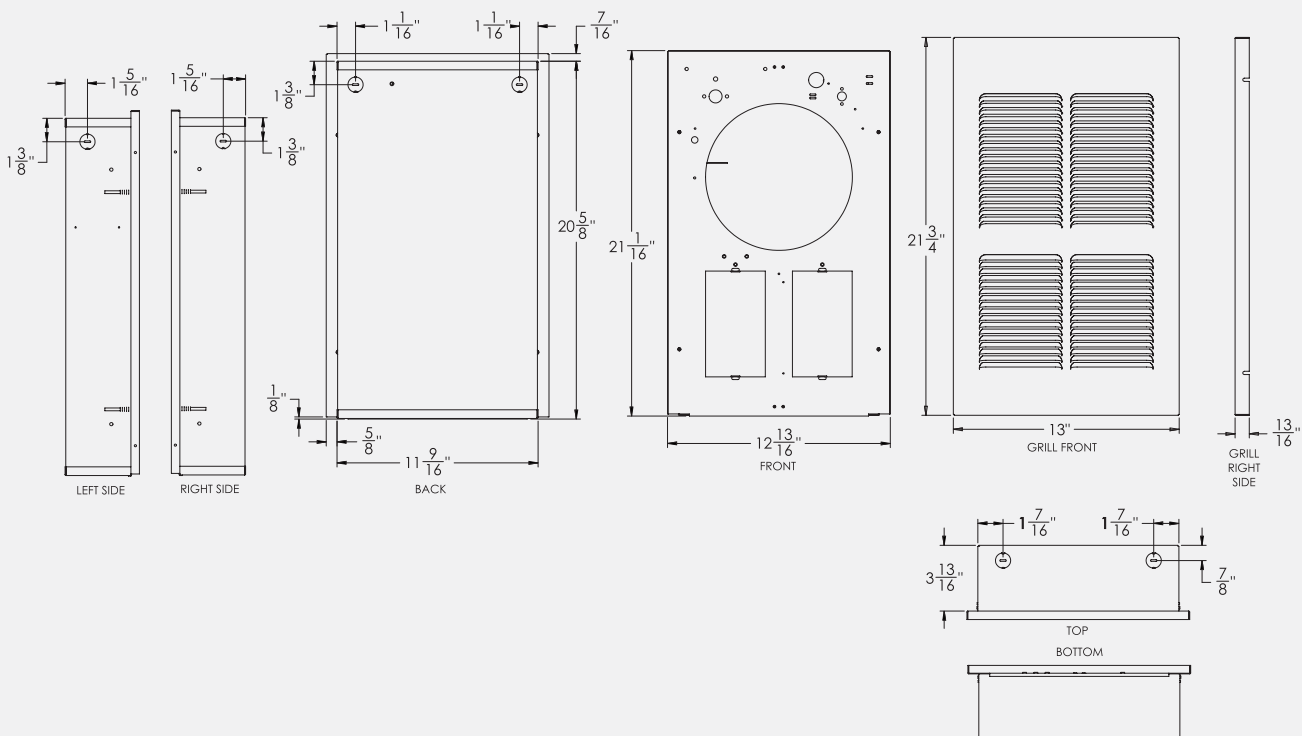

Large Wall Heater LPW ComfortCraft Series 2

Model Code:

LPW 24 45 -T -S2 -WD -R
A B C D E F G

- A: Series
- B: 12 - 120V 24 - 240V
20 - 208V 27 - 277V
- C: Watts (1250 to 4500)
- D: Thermostat (optional)
- E: Series 2
- F: Color
- G: Retail Packaging

ComfortCraft



Pic-A-Watt
Selectable Wattage Element

- Modern curved design
- Dual Pic-A-Watt® elements
- Multiple wattage options
- Long life unit bearing motor
- 5-blade aluminum fan
- 20 Gauge powder-coated grill
- Selector switch: fan/heat/off
- Patented Smart Limit Protection®
- Standard color: white dove
- Design colors available
- 120, 208, 240, or 277 volts
- 5-year limited warranty



The LPW ComfortCraft Series 2 Large Wall Heater

King redefines comfort with a sleek and modern new architectural design. Offerings higher output than our industry leading PAW heater. King's exclusive dual Pic-A-Watt steel fin elements allow customers to select from a range of wattage options, tailoring the heater to an area's specific heating requirements. With up to 4500W, this is our most popular large wall heater, used in both residential and commercial applications. Standard with a 3-position selector switch, it has a fan delay to help dissipate heat from the high-mass steel plate fin elements thereby prolonging heater life and increasing energy efficiency. The high quality built-in thermostat has degrees on the label so temperature selection is easy and accurate.

DESIGNER COLORS AVAILABLE



“Complete” Stock Models For other color grill options use "Order A'la Carte" chart below to build your own complete heater.

BASE MODEL	VOLTS	COLOR	WATTS	AMPS	SHIP WEIGHT lbs
LPW1227T-S2-WD-R	120	White Dove	1250•1500•1750•2000•2250•2750	10.4 - 22.9	19.0
LPW2045T-S2-WD-R	208	White Dove	2250•2750•3000•3250•3500•3750•4000•4500	10.8 - 21.6	19.0
LPW2445T-S2-WD-R	240/208*	White Dove	2250•2750•3000•3250•3500•3750•4000•4500	9.4 - 18.8	19.0
LPW2445T-S2-AD-R	240/208*	Almondine	2250•2750•3000•3250•3500•3750•4000•4500	9.4 - 18.8	19.0
LPW2445T-S2-SN-R	240/208*	Satin Nickel	2250•2750•3000•3250•3500•3750•4000•4500	9.4 - 18.8	19.0
LPW2445T-S2-OB-R	240/208*	Oiled Bronze	2250•2750•3000•3250•3500•3750•4000•4500	9.4 - 18.8	19.0

(-R) Full color consumer packaging

*Dual rated heaters will draw 13% less amps and 25% less wattage when operated at 208V.

NOTE: Not all configurations listed above are stock items (A+ or A stock code). Refer to price book for the Stock code. For non-stock items refer to the table below to order heater parts separately.

Order A'la Carte **To build your own “Complete” with designer grill options (not noted above) select HRC model of proper voltage and LPWG grill model of proper color.

STEP 1: Order Heatbox Interior and Recessed Wall Can

ADD SUFFIX	UPC	DESCRIPTION	SHIP WEIGHT lbs
LPW1227T-S2-HRC	32635	LPW SERIES 2, 120V 2750W, Heatbox Interior & Recessed Wall Can	11.5
LPW2045T-S2-HRC	32636	LPW SERIES 2, 208V 4500W, Heatbox Interior & Recessed Wall Can	11.5
LPW2445T-S2-HRC	32637	LPW SERIES 2, 240V 4500W, Heatbox Interior & Recessed Wall Can	11.5
LPW2740T-S2-HRC	32644	LPW SERIES 2, 277V 4000W, Heatbox Interior & Recessed Wall Can	11.5

STEP 2: Order Grill

MODEL	UPC	DESCRIPTION	SHIP WEIGHT lbs
LPWG-S2-WD	32624	LPW SERIES 2, Grill, White Dove Color	4.5
LPWG-S2-AD	32627	LPW SERIES 2, Grill, Almondine Color	4.5
LPWG-S2-SN	32625	LPW SERIES 2, Grill, Satin Nickel Color	4.5
LPWG-S2-OB	32626	LPW SERIES 2, Grill, Oiled Bronze Color	4.5

NOTE: This is the quickest option when the factory installed heaters options are not in stock.

Accessories

MODEL	UPC	DESCRIPTION	SHIP WEIGHT lbs
LPWSMF-WD	32620	LPW, Surface Mount Frame, White Dove Color	2
LPWSMF-AD	32623	LPW, Surface Mount Frame, Almondine Color	2
LPWSMF-SN	32621	LPW, Surface Mount Frame, Satin Nickel Color	2
LPWSMF-OB	32622	LPW, Surface Mount Frame, Oiled bronze Color	2

** Kraft box packaging

Engineering Specifications

Contractor shall supply and install LPW Series in-wall mounted forced-air electric heaters manufactured by King Electrical Mfg. Company, of the wattage and voltage as indicated on the plans.

Motor: Heavy-duty, cast iron, unit bearing, permanently lubricated with 20cc oil reservoir, 1440 RPM. Enclosed impedance protected with intake air cooling motor for increased bearing life.

Fan: High efficiency, dynamically balanced 5-blade aluminum fan. 185 CFM.

Thermostat: 1-Pole built-in thermostat 45-80°F operating range.

Elements: Element assemblies shall consist of three steel sheathed heating tubes in a furnace-brazed, plate-finned, block design. Each sheathed tube shall contain coiled Ni-Chrome wire, embedded in an insulator of Magnesium Oxide. The element assembly shall provide up to eight (8) possible wattage configurations available for selection during field installation. The use of external resistors, diodes, or other weak links to obtain multiple wattages will not be accepted.

Thermal Overload: Heaters shall be equipped with King's patented

thermal overload Smart Limit Protection®, which disconnects elements and motor in the event normal operating temperatures are exceeded. If thermal overload trips due to abnormal operating temperatures, thermal overload shall remain open until manually reset by turning the heater off for 15 minutes.

Fan / Heat / Off Switch: 3-position switch provides heating and summer fan-only operation. The DPST off switch provides a "positive off" that disconnects all ungrounded conductors.

Wall-box: 20 gauge electro-galvanized steel with factory installed ground-wire. Minimum 4" clearance to floors and 6" to sidewalls. Zero clearance to combustibles in the wall. Recommended 10" clearance to floors and 16" to sidewalls.

Grill: 20 gauge steel finished in a gloss white, powder-coated paint.

Options: Retrofit grill, and surface wall-box.

Approvals: cULus

Dimensional Data

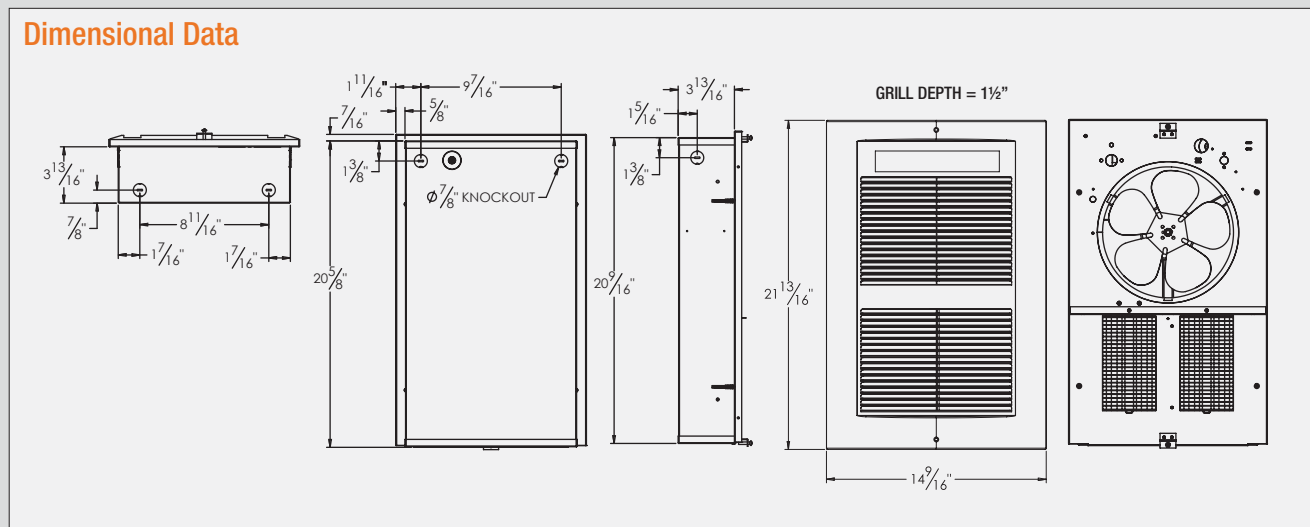

Electronic Wall Heater LPW ECO2S Series

Model Code:

LPW 24 45-ECO-WD-R
A B C D E F

- A: Series
- B: 12 - 120V 24 - 240V
20 - 208V
- C: Watts 45-(2500-4500W)
27-(1500-2750W)
- D: ECO2S Controller
- E: Color
- F: Retail Packaging



- Modern Curved Design
- ECO2S Electronic Controller
- Energy Efficient 2-Stage Heating
- Fan Only & Timer Modes
- Remote Control Included
- Dual Pic-A-Watt® Elements
- Patented Smart Limit Protection®
- 5-Blade Aluminum Fan
- 20 Gauge Powder-Coated Grill
- Long Life Unit Bearing Motor
- Standard Color: White Dove
- Design Colors Available
- 120, 208, or 240 Volts
- 5-Year Limited Warranty



The LPW ECO2S Series Electronic 2-Stage Smart Wall Heater w/ Remote

King redefines comfort with the smart series LPW ECO2S. Combining a sleek and modern architectural design with the unparalleled performance, energy efficiency and user control of the ECO2S 2-stage electronic controller with remote. The LPW ECO2S delivers maximum energy efficiency with automatic 2-stage heating, automatically uses the lowest wattage needed to heat the room. Includes both fan only and timer mode options, as well as a remote control for simple operation. King's exclusive dual Pic-A-Watt steel fin elements allow customers to select from a range of wattage options, tailoring the heater to an area's specific heating requirements, up to 4500W. An ideal choice for both residential and commercial applications.

ECO2S Electronic Controller Features:

- Electronic control for accuracy
- Energy-saving automatic 2-stage heating
- Large LED display
- Remote control and wall bracket included
- Thermostat timer mode (1-9 Hours)
- Fan only mode
- Built-In fan delay



DESIGNER COLORS AVAILABLE



"Complete" Stock Models For other color grill options use "Order A la Carte" chart below to build your own complete heater.

BASE MODEL	VOLTS	COLOR	WATTS	AMPS	SHIP WEIGHT lbs
LPW1227-ECO-WD-R	120	White Dove	1500•1750•2000•2250•2500•2750	10.4 - 22.9	19.0
LPW2045-ECO-WD-R	208	White Dove	2500•3000•3500•4000•4500	10.8 - 21.6	19.0
LPW2445-ECO-WD-R	240/208*	White Dove	2500•3000•3500•4000•4500	9.4 - 18.8	19.0
LPW2445-ECO-AD-R	240/208*	Almondine	2500•3000•3500•4000•4500	9.4 - 18.8	19.0
LPW2445-ECO-SN-R	240/208*	Satin Nickel	2500•3000•3500•4000•4500	9.4 - 18.8	19.0
LPW2445-ECO-OB-R	240/208*	Oiled Bronze	2500•3000•3500•4000•4500	9.4 - 18.8	19.0

(-R) Full color consumer packaging

*Dual rated heaters will draw 13% less amps and 25% less wattage when operated at 208V.

NOTE: Not all configurations listed above are stock items (A+ or A stock code). Refer to price book for the Stock code. For non-stock items refer to the table below to order heater parts separately.

Electronic Wall Heater LPW ECO2S Series

Order A'la Carte **To build your own "Complete" with designer grill options (not noted above) select HRC model of proper voltage and LPWG grill model of proper color.

STEP 1: Order Heatbox Interior and Recessed Wall Can

ADD SUFFIX	UPC	DESCRIPTION	SHIP WEIGHT lbs
LPW1227-ECO-HRC	32638	LPW ECO, 120V 2750W, Heatbox Interior & Recessed Wall Can	11.5
LPW2045-ECO-HRC	32639	LPW ECO, 208V 4500W, Heatbox Interior & Recessed Wall Can	11.5
LPW2445-ECO-HRC	32640	LPW ECO, 240V 4500W, Heatbox Interior & Recessed Wall Can	11.5

STEP 2: Order Grill

MODEL	UPC	DESCRIPTION	SHIP WEIGHT lbs
LPWG-ECO-WD	32628	LPW ECO, Grill, White Dove Color	4.5
LPWG-ECO-AD	32631	LPW ECO, Grill, Almondine Color	4.5
LPWG-ECO-SN	32630	LPW ECO, Grill, Satin Nickel Color	4.5
LPWG-ECO-OB	32629	LPW ECO, Grill, Oiled Bronze Color	4.5

NOTE: This is the quickest option when the factory installed heaters options are not in stock.

Accessories

MODEL	UPC	DESCRIPTION	SHIP WEIGHT lbs
LPWSMF-WD	32620	LPW, Surface Mount Frame, White Dove Color	2.0
LPWSMF-AD	32623	LPW, Surface Mount Frame, Almondine Color	2.0
LPWSMF-SN	32621	LPW, Surface Mount Frame, Satin Nickel Color	2.0
LPWSMF-OB	32622	LPW, Surface Mount Frame, Oiled bronze Color	2.0
61747	61747	ECO2S Replacement Infrared Remote Control	0.125

** Kraft box packaging

Engineering Specifications

Contractor shall supply and install LPW-ECO2S Series in-wall mounted forced-air electric heaters manufactured by King Electrical Mfg. Company, of the wattage and voltage as indicated on the plans.

Motor: Heavy-duty, cast iron, unit bearing, permanently lubricated with 20cc oil reservoir, 1440 RPM. Enclosed impedance protected with intake air cooling motor for increased bearing life.

Fan: High efficiency, dynamically balanced 5-blade aluminum fan. 185 CFM.

Electronic Control: Up, down temperature mode. Start/Stop. Standard on all heaters. The control voltage is equal to the line voltage.

Elements: Element assemblies shall consist of three steel sheathed heating tubes in a furnace-brazed, plate-finned, block design. Each sheathed tube shall contain coiled Ni-Chrome wire, embedded in an insulator of Magnesium Oxide. The element assembly shall provide up to six (6) possible wattage configurations available for selection during field installation. The use of external resistors, diodes, or other weak links to obtain multiple wattages will not be accepted.

Thermal Overload: Heaters shall be equipped with King's patented thermal overload Smart Limit Protection®, which disconnects elements and motor in the event normal operating temperatures are exceeded. If thermal overload trips due to abnormal operating temperatures, thermal overload shall remain open until manually reset by turning the heater off for 15 minutes.

Fan / Heat / Off: Electronic Controller provides heating and summer fan-only operation.

Wall-box: 20 gauge electro-galvanized steel with factory installed ground-wire. Minimum 4" clearance to floors and 6" to sidewalls. Zero clearance to combustibles in the wall. Recommended 10" clearance to floors and 16" to sidewalls.

Grill: 20 gauge steel finished in a gloss white, powder-coated paint.

Options: Wired for remote thermostat, retrofit grill, and surface wall-box.

Approvals: cULus

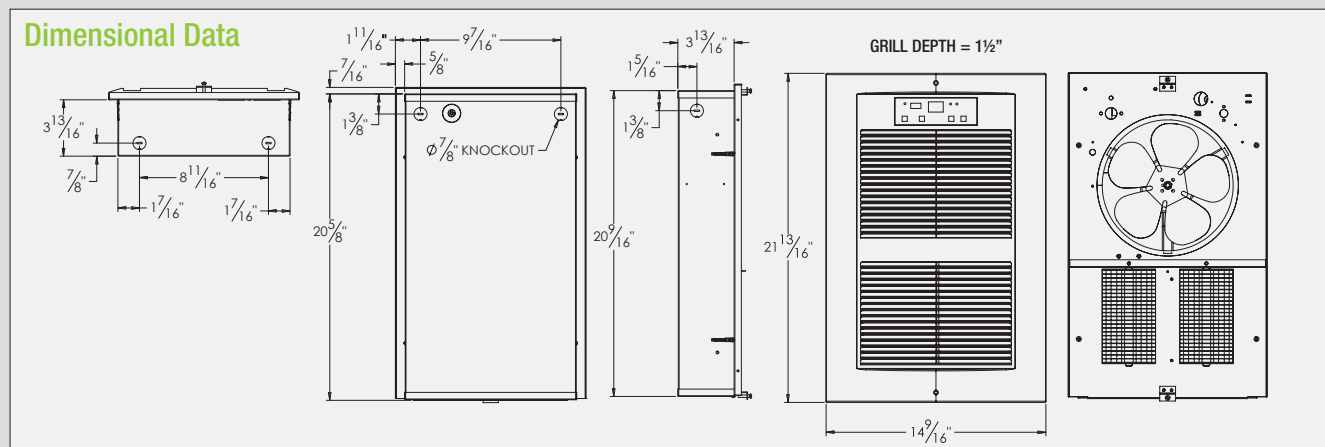

Vandal Resistant Heater LPWW Series



Model Code:

LPWW	24	15	-TP
A	B	C	D
A: Series			
B: 12 - 120V 24 - 240V			
20 - 208V 27 - 277V			
C: Watts (500 to 1500)			
D: Thermostat (optional)			



Pic-A-Watt



- Pic-A-Watt® element
- Impact/Vandal resistant
- Cast iron motor
- 5-Blade aluminum fan
- Patent Smart Limit Protection®
- Multiple wattages
- 3/16" plate steel grill
- Selector switch: fan/heat/off
- Available in 120, 208, 240, or 277 volts
- 5-year limited warranty



The LPWW Vandal Resistant Heater

High traffic areas, such as detention areas, public rest rooms, rest areas, and any public areas needing vandal resistance are best heated with the LPWW Series. The heavy grill and 3/16" solid steel frame can withstand heavy impact and abuse. Tamper-resistant screws prevent unauthorized disassembly of the grill. Controls are recessed out of reach of fiddling fingers. Moderate wattage and high airflow capacities replenish entryways and hallways to prevent drafts from entering the building's core. Minimum and maximum security level 3 & 4.

Ordering Information *Add suffix -BZ for Bronze finish

MODEL	UPC	VOLTS	WATTS	AMPS	SHIP WEIGHT lbs
LPWW1215	18286	120	1250 • 1500	10.4-12.5	24
LPWW2015	18287	208	500•750•1000•1500	2.4-7.2	24
LPWW2415	18288	240/208*	500•750•1000•1500	2.1-6.3	24
LPWW2715	18289	277	500•750•1000•1500	1.8-5.4	24

*Dual rated heaters will draw 13% less amps and 25% less wattage when operated at 208V.

Engineering Specifications

Contractor shall supply and install LPWW Vandal Resistant Series in-wall mounted forced-air electric heater manufactured by King Electrical Mfg. Company, of the wattage and voltage as indicated on the plans.

Grill: Heavy 3/16" thick plate with 5/16" hole pattern grille provides high impact resistance to damage. Grill is attached with tamper-proof 1/4"-20 screws (hex socket/pinned). All controls are accessed through grill with slotted screwdriver. Standard color is white. Optional dark bronze available.

Elements: Element assemblies shall consist of steel sheathed heating tubes in a furnace brazed, plate-finned, block design. Each sheathed tube shall contain coiled Ni-Chrome wire embedded in an insulator of Magnesium Oxide. The element assembly shall provide wattage configurations available for selection during field installation. The use of external resistors, diodes, or other weak links to obtain multiple wattages will not be accepted.

Optional Built-in Thermostat: Single Pole factory installed hydraulic capillary tube with precision control. Operating range 40°F to 90°F. Thermostat is tamper-proof to prevent unauthorized adjustment.

Fan Delay Switch: The fan continues to operate after the thermostat shuts off in order to remove the residual heat remaining in the elements.

Fan / Heat / Off Switch: Tamper-proof 3-position switch provides heating and summer fan-only operation. The DPST off switch provides a "positive off" that disconnects all ungrounded conductors. Controls are accessed through grill with slotted screwdriver.

Unit Bearing Motor: Permanently lubricated cast iron motor with enclosed rotor provides long-lasting, trouble-free operation and a 20cc oil reservoir. Thermally protected. 1300 RPM.

Thermal Overload: Heaters shall be equipped with King's patented thermal overload Smart Limit Protection®, which disconnects elements and motor in the event normal operating temperatures are exceeded. If thermal overload trips due to abnormal operating temperatures, thermal overload shall remain open until manually reset by turning the heater off for 15 minutes.

Wall-box: 20 gauge electro-galvanized steel with 18 gauge reinforcements. Factory installed ground-wire. Minimum 4" clearance to floors and 6" to sidewalls. Zero clearance to combustibles in the wall. Recommended 10" clearance to floors and 16" to sidewalls. Optional Circuit Breaker / Disconnect

Approvals: cULus

Dimensional Data

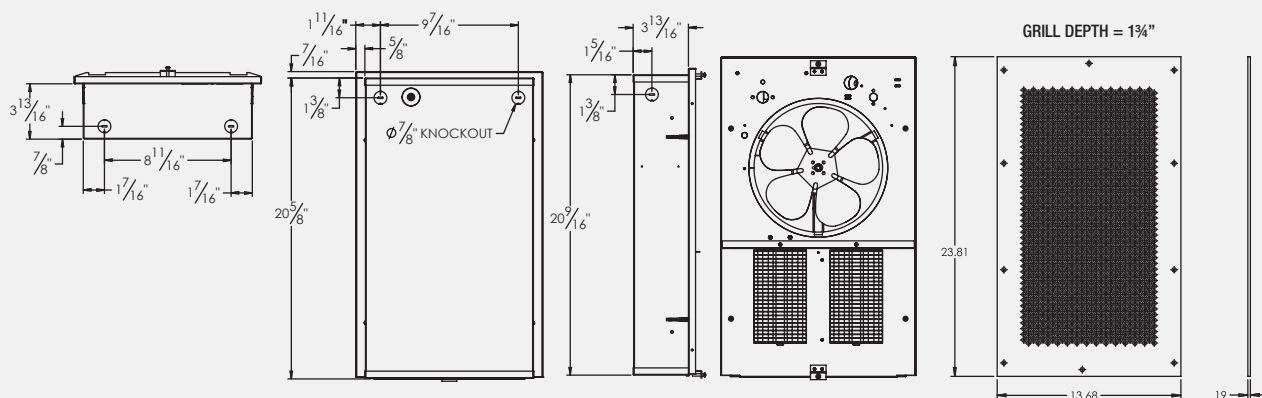

Options/Accessories

ADD SUFFIX	DESCRIPTION	WEIGHT lbs
-BZ	Grill - Bronze	24
-W	Grill - White	24
-CT24	Transformer that converts 208, 240 and 277 Volts to 24 Volt Control Circuit {add power contactor (-CX) for 3kW - 5kW 1-Phase models}	24.5
-TP	Factory Installed Tamper-proof Thermostat	24
-CB	Circuit Breaker / Disconnect 20A	0.5

MODEL	UPC	DESCRIPTION	WEIGHT lbs
UWICV	12593	Recess Wall Can	6.5
LPWSAV	12594	Surface Mount Wall Box White	6.5
LPWSAV-BZ	12596	Surface Mount Wall Box Bronze	3.0

Exploded View



WIRING DIAGRAM

for remote thermostat installation

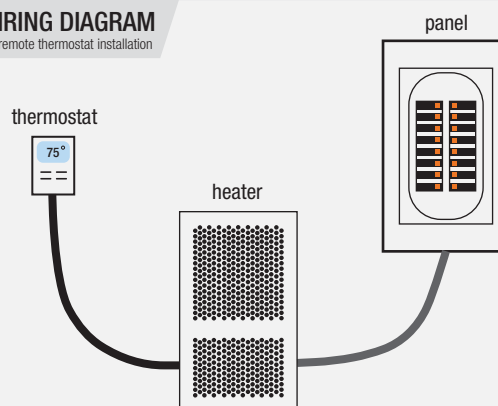

Power must be routed to heater first, then to remote thermostat.

Tamper-proof Screw

Grill is attached with tamper-proof 1/4"-20 screws (hex socket/pinned).



Architectural Heater LPWA Series



Model Code:

LPWA	24	45	-TP
A	B	C	D
A: Series			
B: 12 - 120V 24 - 240V			
20 - 208V 27 - 277V			
C: Watts (1500 to 4500)			
D: Thermostat (optional)			



Pic-A-Watt
Steel Fin Element



- Pic-A-Watt® Element
- Tamper Resistant
- Long life Unit Bearing Motor
- 5-Blade Aluminum Fan
- Patented Smart Limit Protection®
- Multiple wattages
- Extruded aluminum grill
- Selector Switch: Fan/Heat/Off
- 120, 208, 240, or 277 Volts
- Standard color silver,
- bronze white & black optional
- 5-year limited warranty



The LPWA Architectural Heater

Entryways, corridors and all public areas are best heated with the LPWA Series. The heavy duty grill and frame can withstand heavy traffic and abuse. Tamper-resistant screws prevent unauthorized disassembly of the grill. Controls are recessed out-of-reach of fiddling fingers. High wattage and airflow capacities replenish entryways and hallways to prevent drafts from entering the building's core.

Ordering Information *Add suffix -BZ for bronze, -W for white and -B for black

	MODEL	UPC	COLOR	VOLTS	WATTS	AMPS	SHIP WEIGHT lbs
120V	LPWA1215	18370	Silver	120	1500	12.5	24
	LPWA1220	18372	Silver	120	2000	16.7	24
	LPWA1227	18250	Silver	120	2750	22.9	24
208V	LPWA2020	18374	Silver	208	2000	9.6	24
	LPWA2030	18376	Silver	208	3000	14.4	24
	LPWA2040	18251	Silver	208	4000	19.2	24
	LPWA2045	18240	Silver	208	4500	21.6	24
	LPWA2420	18378	Silver	240/208*	2000/1500	8.3/7.2	24
240V	LPWA2430	18380	Silver	240/208*	3000/2250	12.5/10.9	24
	LPWA2440	18382	Silver	240/208*	4000/3000	16.6/14.4	24
	LPWA2445	18193	Silver	240/208*	4500/3375	18.75/16.3	24
277V	LPWA2720	18384	Silver	277	2000	7.2	24
	LPWA2730	18386	Silver	277	3000	10.8	24
	LPWA2740	18252	Silver	277	4000	14.4	24

*Dual rated heaters will draw 13% less amps and 25% less wattage when operated at 208V.

Engineering Specifications

Contractor shall supply and install LPWA Series in-wall mounted forced-air electric heaters manufactured by King Electrical Mfg. Company, of the wattage and voltage as indicated on the plans

Grill: Heavy duty extruded 12 gauge aluminum provides high impact resistance to damage. Grill is attached with tamper-proof screws (hex socket/pinned). All controls are easily accessed through grill with slotted screwdriver. Standard color is anodized silver. Dark bronze or white is available.

Elements: Element assemblies shall consist of steel sheathed heating tubes in a furnace-brazed, plate finned, block design. Each sheathed tube shall contain a coiled Ni-Chrome wire embedded in an insulator of Magnesium Oxide. The element assembly shall provide the specific wattage as indicated.

Optional Built-in Thermostat: Single Pole factory installed hydraulic capillary tube with precision control. Operating range 40°F to 90°F. Thermostat is tamper-proof to prevent unauthorized adjustment.

Fan / Heat / Off Switch: Tamper-proof 3-position switch provides heating and summer fan-only operation. The DPST off switch provides a "positive off" that disconnects all ungrounded conductors. Controls are easily accessed through grill with slotted screwdriver.

Thermal Overload: Heaters shall be equipped with King's patented thermal overload Smart Limit Protection®, which disconnects elements and motor in the event normal operating temperatures are exceeded. If thermal overload trips due

to abnormal operating temperatures, thermal overload shall remain open until manually reset by turning the heater off for 15 minutes.

Fan Delay Switch: The fan continues to operate after the thermostat shuts off in order to remove the residual heat left in the elements.

Unit Bearing Motor: Permanently lubricated cast iron motor with enclosed rotor provides long-lasting, trouble-free operation and a 20cc oil reservoir. Thermally protected. 1300 RPM.

Wall box: 20 gauge electro-galvanized steel. Factory installed ground-wire. Minimum 4" clearance to floors and 6" to sidewalls. Zero clearance to combustibles in the wall. Recommended 10" clearance to floors and 16" to sidewalls.

Thermal Overload: Heaters shall be equipped with King's patented thermal overload Smart Limit Protection®, which disconnects elements and motor in the event normal operating temperatures are exceeded.

Optional Circuit Breaker / Disconnect: 20 Amp or 30 Amp
Control: Transformer Relay 24V
Approvals: cULus

Dimensional Data

MINIMUM CLEARANCE: Zero clearance to insulation recommended 10" above floor 6" from adjacent wall surface

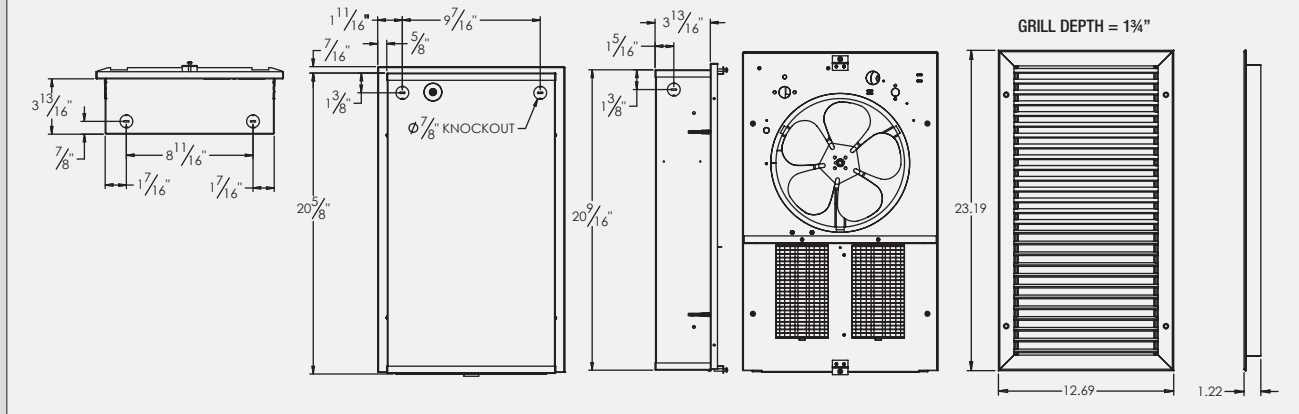

Options

ADD SUFFIX	DESCRIPTION	WEIGHT lbs
-B	Grill - Black	24
-BZ	Grill - Bronze	24
-W	Grill - White	24
-CT24	Transformer that converts 208, 240 and 277 Volts to 24 Volt Control Remote Circuit (add power contactor (-CX) for 3kW - 5kW 1-Phase models)	24.5
-S	Surface Can Included	24
-TP	Factory Installed Tamper-proof Thermostat	24
-CB2	20 Amp Double Pole Circuit Breaker / Disconnect	0.5
-CB3	30 Amp Double Pole Circuit Breaker / Disconnect	0.5

Accessories

MODEL	UPC	DESCRIPTION	WEIGHT lbs
LPWAIC	18200	Architectural Recess Wall Can	6.5
LPWASA-B	17345	Surface Can Black	5
LPWASA-BZ	18202	Surface Can Bronze	5
LPWASA	18197	Surface Can Silver	5
LPWASA-W	18201	Surface Can White	5
LPWAG-G	18158	LPWA Series Grill - Silver	7
LPWA-TP	18140	Tamper-proof Thermostat Replacement	2

WIRING DIAGRAM

for remote thermostat installation

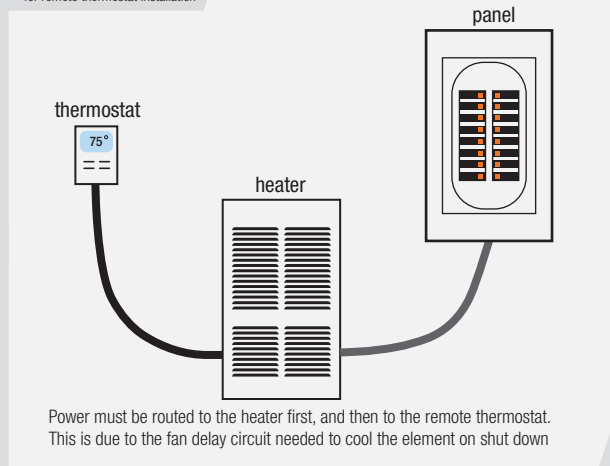

Colors

Standard



Silver

Bronze

White

Black

Kickspace Heater KT-MW Series



Model Code:

KT	12	10	-T
A	B	C	D
A: Series			
B: 12 - 120V 24 - 240V			
C: Watts (500 to 1500)			
D: Thermostat (optional)			



- Open coil nichrome elements
- C-Frame motor
- Squirrel cage blower
- Patented Smart Limit Protection®
- 20 gauge powder coated grill
- Dual wattage
- Standard color: white
- Optional almond, black, & stainless steel
- 120 or 240 volts
- Low profile
- 1-year limited warranty



The KT-MW Kickspace Heater

This narrow profile heater is only 3½" tall and specifically designed to conveniently fit under kitchen or bathroom cabinets, providing warm air for cold bathroom or kitchen. Valuable floor and wall space is saved. The optional KTG-24W Retrofit Grill allows for easy replacement of older kickspace heaters. Install heater and fit with long grill to cover existing cutout. For applications other than kickspace use KTG-OL Grill. Check floor covering manufacturer's recommendation for acceptable surface temperature.

Ordering Information *Add suffix -W for White Grill or -B for Black Grill

BASE MODEL	VOLTS	WATTS	AMPS	SHIP WEIGHT lbs
KT1215-MW	120	250•500•750•1000•1250•1500	2.1 - 12.5	8.5
KT2415-MW	240/208*	250•500•750•1000•1250•1500	1.0 - 6.25	8.5

*Dual rated heaters will draw 13% less amps and 25% less wattage when operated at 208V.

Factory Installed Options

ADD SUFFIX	DESCRIPTION	SHIP WEIGHT lbs
-B	Black Color	0
-W	White Color	0
-SS	Stainless Steel Color	0
-T	Factory Installed Single Pole Thermostat Kit	9
-T2	Factory Installed Double Pole Thermostat Kit	9
-HRC	Interior & Recessed Wall Can	7.5
-DS15	Factory Installed Double Pole Disconnect (10A/ 240V / 15A/120V)	11

NOTE: Not all configurations listed above are stock items (A+ or A stock code). Refer to price book for the Stock code. For non-stock items refer to the table below to order heater parts separately.

Order A'la Carte **To build your own "Complete" with designer grill options (not noted above) select HRC model of proper voltage and KTG grill model of proper color.

STEP 1: Order Heatbox Interior

ADD SUFFIX	UPC	DESCRIPTION	SHIP WEIGHT lbs
KT1215-MW-HRC	32714	KT Kick Space HTR 120V 1500W Interior & Recessed Wall Can	7.5
KT2415-MW-HRC	32718	KT Kick Space HTR 240/208V 1500W/1125W Interior and Recessed Wall Can	7.5

STEP 2: Order Grill

MODEL	UPC	DESCRIPTION	SHIP WEIGHT lbs
KTG-A	12296	Grill - Almond - 3-1/2" x 16-1/2"	1.0
KTG-B	12297	Grill - Black - 3-1/2" x 16-1/2"	1.0
KTG-W	12295	Grill - White - 3-1/2" x 16-1/2"	1.0
KTG-SS-3-1/2	12267	Grill - Overlap 1/2" on All Sides - Stainless Steel - 4-1/2" x 16-1/2"	1.1
KTG-OL-B	12268	Grill - Black - 3-1/2" x 16-1/2"	1.1
KTG-OL-W	12275	Grill - Overlap 1/2" on All Sides - White - 4-1/2" x 16-1/2"	1.1
KTG-SS	12269	Grill - Overlap 1/2" on All Sides - Stainless Steel - 4-1/2" x 16-1/2"	1.1

NOTE: This is the quickest option when the factory installed heaters options are not in stock.

Kickspace Heater KT-MW Series

Accessories

MODEL	UPC	DESCRIPTION	SHIP WEIGHT lbs
TKIT-1BW	20654	Built-in Single Pole Single Throw Thermostat Kit, Bright White	0.5
TKIT-2BW	20655	Built-in Double Pole Single Throw Thermostat Kit, Bright White	0.5
TKIT-1A	11058	Built-in Single Pole Single Throw Thermostat Kit, Almond	0.5
TKIT-2A	11059	Built-in Single Pole Single Throw Thermostat Kit, Almond	0.5
TKIT-1BL	17346	Wall Heater Accessory SP Thermostat Kit Black	0.5
TKIT-2BL	17347	Wall Heater Accessory DP Thermostat Kit Black	0.5

Engineering Specifications

Contractor shall supply and install KT Series limited space-mounted forced air electric heaters manufactured by King Electrical Mfg. Company. Heaters shall be of the wattage and voltage as indicated on the plans.

Ratings: Heaters shall be available in wattages of 500 to 1,500 at 120 Volts or dual rated from 208 Volts to 240 Volts.

Blower and Motor: A tangential cylindrical blower, delivering 70 CFM, shall be driven by a shaded pole, permanently lubricated, C-frame type motor with impedance protection and sealed bearings. Motors shall be the same voltage as the heater.

Elements: Element assemblies shall be dual element construction of coiled Nickel Chromium alloy, corrosion resistant wire strung through a minimum of four rows of mica insulator. Element assemblies shall have factory provided connection to allow field modification to 50% wattage at time of installation.

Grill: The grill shall be a louvered, one-piece design. The grill shall be epoxy powder-coated in the color specified on the plans.

Thermal Overload: Heaters shall be equipped with King's patented thermal overload Smart Limit Protection®, which disconnects elements and motor in the event normal operating temperatures are exceeded. If thermal overload trips due to abnormal operating temperatures, thermal overload shall remain open until manually reset by turning the heater off for fifteen minutes. Automatic reset of thermal overloads, which allow the element to continue to cycle under abnormal conditions, will not be accepted.

Wall Can: The wall can shall be 20 gauge electrogalvanized steel and contain knockouts. The wall can shall be supplied with a factory installed ground wire. Zero Clearance to floors and 6" to sidewalls.

Approvals: cULus (E41422)

Dimensional Data

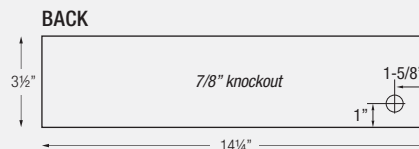
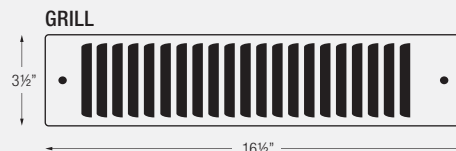
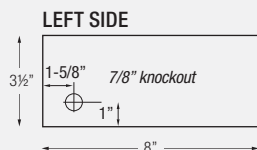
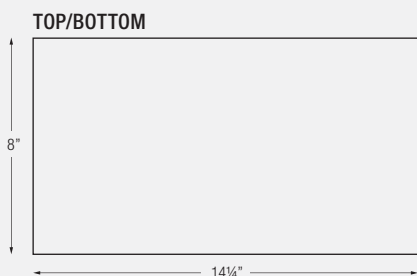

Installation

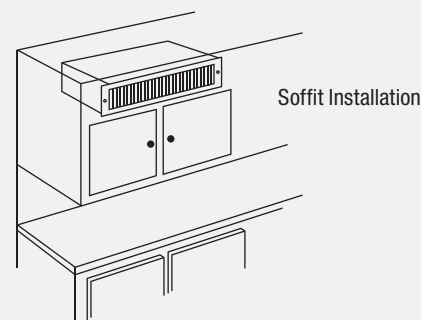
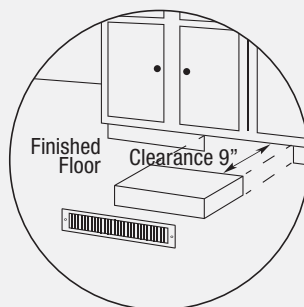
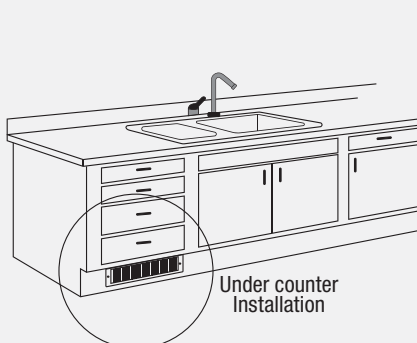

Multi-Watt Horizontal/Vertical Heater KTW Series



Model Code:
KTW 12 15-HLS -RGB -T
A B C D E F
A: Series
B: 12 - 120V 24 - 240V
C: Watts (250 to 1500)
D: High/Low Switch
E: Grill Style
F: Thermostat (optional)



- Triple Coil Nichrome Element
- C-Frame Motor
- Squirrel Cage Blower
- Patented Smart Limit Protection®
- 20 Gauge Powder Coated Grill
- 7 Wattages in one heater
- Standard Color: Black, (optional almond, white or stainless)
- Low Profile
- 120 or 240 volts
- 2-year limited warranty



Horizontal / Vertical Heater

King introduces another first. The only convertible cabinet heater that can be installed either vertically or horizontally on the market. This narrow profile heater is only 3-5/8" tall and specifically designed to fit into kitchen or bathroom cabinets, providing warm comfortable air for a cold bathrooms or kitchens saving valuable floor and wall space. For application other than kickspace, use the KTW-TG Grill.

Order A'la Carte **To build your own "Complete" select HRC model of proper voltage and KTW-RG grill model of proper color.

STEP 1: Order Heatbox Interior and Recessed Wall Can

ADD SUFFIX	UPC	DESCRIPTION	SHIP WEIGHT lbs
KTW1215-HLS-HRC	14005	KTW HTR 120V 1500W W/HI-LOW SW Heatbox Interior & Recessed Can Only	10.0
KTW2415-HLS-HRC	14006	KTW HTR 240/208V 1500/1125 W/HI-LOW SW Heatbox Interior & Recessed Can Only	10.0

STEP 2: Order Grill

MODEL	UPC	DESCRIPTION	SHIP WEIGHT lbs
KTW-RG-B	20578	Grill, Recessed - Black	1.0
KTW-RG-A	20577	Grill, Recessed - Almond	1.0
KTW-RG-SS	20579	Grill, Recessed - Stainless Steel	1.0
KTW-RG-W	20580	Grill, Recessed - White	1.0
KTW-TG-A	20581	Grill, SurfaceTrim - Almond	1.0
KTW-TG-B	20582	Grill, SurfaceTrim - Black	1.0
KTW-TG-SS	20583	Grill, SurfaceTrim - Stainless Steel	1.0
KTW-TG-W	20584	Grill, SurfaceTrim - White	1.0

NOTE: This is the quickest option when the factory installed heaters options are not in stock.

Accessories

MODEL	UPC	DESCRIPTION	SHIP WEIGHT lbs
TKIT-1BW	20654	Built-in Single Pole Single Throw Thermostat Kit, Bright White	0.5
TKIT-2BW	20655	Built-in Double Pole Single Throw Thermostat Kit, Bright White	0.5
TKIT-1A	11058	Built-in Single Pole Single Throw Thermostat Kit, Almond	0.5
TKIT-2A	11059	Built-in Double Pole Single Throw Thermostat Kit, Almond	0.5
TKIT-1BL	17346	Wall Heater Accessory SP Thermostat Kit Black	0.5
TKIT-2BL	17347	Wall Heater Accessory DP Thermostat Kit Black	0.5

Engineering Specifications

Contractor shall supply and install, KTW Series limited space forced-air electric heaters, manufactured by King Electrical Mfg. Company.

Heaters shall be of the wattage and Voltage as indicated on the plans.

Ratings: Heaters shall be available in wattages of 250 to 1,500 at 120 volts or dual rated from 208 volts to 240 volts.

Blower and Motor: A tangential cylindrical blower, delivering 70

CFM, shall be driven by a shaded pole, permanently lubricated, C-frame type motor with impedance protection and sealed bearings. Motors shall be the same voltage as the heater.

Multi-Watt Horizontal/Vertical Heater KTW Series

Elements: Element assemblies shall have a 3-wattage element construction of coiled nickel chromium, alloy corrosion resistant wire strung with a minimum of two rows of muscovite insulator.

Element assemblies shall have factory provided connection to allow field modification of wattage at time of installation.

Thermal Overload: Heaters shall be equipped with King's patented thermal overload Smart Limit Protection®, which disconnects elements and motor in the event normal operating temperatures are exceeded. If thermal overload trips due to abnormal operating temperatures, thermal overload shall remain open until manually reset by turning the heater off for fifteen minutes. Automatic reset of thermal overloads, which allow the element to continue to cycle under abnormal conditions, will not be accepted.

Hi/Lo selector switch: Wattage can be adjusted from 250-1250 watts in the low position and 750-1500 watts in the hi position (HLS Optional).

Wall Can: The wall can shall be 20-gauge steel and shall contain two 1/2" knockouts for power leads. The wall can shall be supplied with a factory installed grounding wire.

Grill: The grill shall be louvered, one piece design. The grill shall be epoxy powder coated in the color specified on the plans or stainless steel.

Approval: cULus (E41422)

Internal View of the KTW

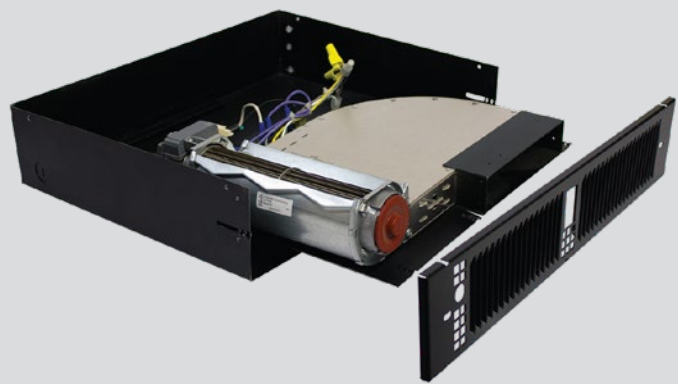

Dimensional Data - KTW

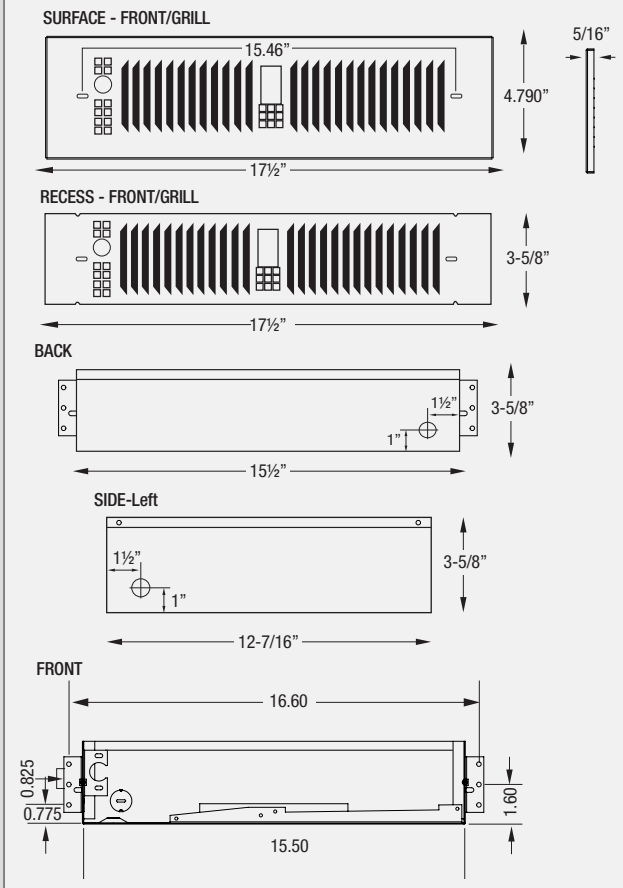

Location for Heater: KTW

This heater has been designed to allow it to be recessed at floor level in the toe space of cabinets or under counters or at the base of walls.

Minimum Clearance In Wall, Vertical Installation

When placed in a wall or a filler section of a cabinet.

Front	Top	Bottom	Sides
36"	0"	2"	0"
91cm	0cm	5cm	0cm

Mounting Options

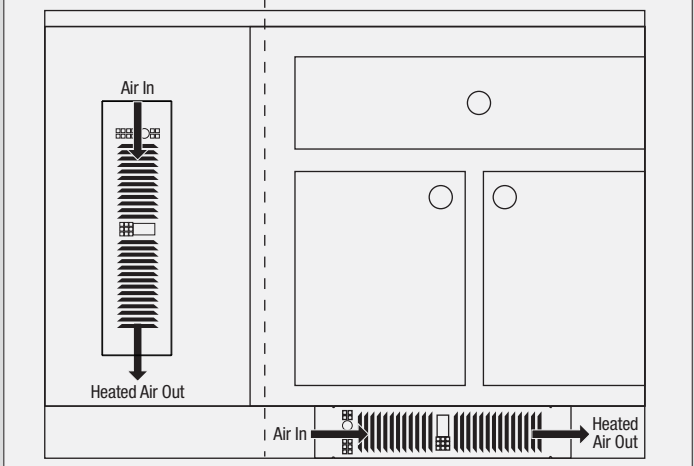

Minimum Clearance In Toe Space Installation

When placed in a wall or a filler section of a cabinet.

Front	Top	Bottom	Sides
36"	0"	0"	6"
91cm	0cm	0cm	15.24cm

Ceiling Heater WHFC Series



Model Code:

WHFC	12	10
A	B	C

A: Series
 B: 12 - 120V 20 - 208V 24 - 240V
 C: Watts (500 to 1500)



- Nichrome open-coil element
- C-Frame motor
- Squirrel cage blower
- Patented Smart Limit Protection®
- Whisper quiet
- Ceiling mount
- Dual wattage
- Recess can with QuickSet™ stops
- Powder coated grill
- Standard color: white (almond optional)
- 3 -year limited warranty

The WHFC Ceiling Heater

This value-priced ceiling heater provides all of the features offered by the original WHF but adds the benefits of a ceiling mounted design. Its extreme value comes from combining the rapid heat transfer of a NiChrome element with the performance of a squirrel cage blower.

Ordering Information *Add suffix -W for White Grill or -A for Almond Grill color

	MODEL	VOLTS	WATTS	AMPS	SHIP WEIGHT lbs
120V	WHFC1210	120	500 • 1000	4.2-8.4	8 lbs
	WHFC1212	120	600 • 1200	5-10	8 lbs
	WHFC1215	120	750 • 1500	6.3-12.5	8 lbs
208V	WHFC2010	208	500 • 1000	2.4-4.8	8 lbs
	WHFC2015	208	750 • 1500	3.6-7.2	8 lbs
240V	WHFC2410	240/208*	500 • 1000	2.1-4.2	8 lbs
	WHFC2415	240/208*	750 • 1500	3.1-6.3	8 lbs

*Dual rated heaters will draw 13% less amps and 25% less wattage when operated at 208V.

Options / Accessories

ADD SUFFIX	DESCRIPTION	SHIP WEIGHT lbs
-W	White Color	
-A	Almond Color	
-I	Interior and Grill Only (no wall can)	6.0
-H	Heat Box Only (no wall can)	5.0
-DS15	Factory Installed Double Pole Disconnect (10A/ 240V / 15A/120V)	8.0

MODEL	UPC	DESCRIPTION	SHIP WEIGHT lbs
WHIC-C	12650	Ceiling Recess Can	3.5
WHSC-C-W	12230	Surface Can - White	4.0
WHFG	12520	Grill - White	2.0
WHFC T-Bar Panel	12133	T-Bar Panel	4.0

Engineering Specifications

Contractor shall supply and install WHFC Series ceiling-mounted forced-air electric heaters manufactured by King Electrical Mfg. Company. Heaters shall be of the wattage and voltage as indicated on the plans.

Ratings: Heaters shall be available in wattages of 500 to 1,500 at 120, 208, or 240 Volts.

Blower and Motor: A tangential cylindrical blower, delivering 70 CFM, shall be driven by a shaded pole, permanently lubricated, C-frame type motor with impedance protection and sealed bearings. Motors shall be the same voltage as the heater. The motor and all wiring shall be totally isolated from the heating chamber for protection from heated air.

Elements: Element assemblies shall be constructed of coiled Nickel Chromium alloy, corrosion resistant wire strung through a minimum of four rows of mica insulator. Element assemblies shall have factory provided connection to allow field modification to 50% wattage at time of installation.

Thermal Overload: Heaters shall be equipped with King's patented thermal overload Smart Limit Protection®, which disconnects elements and motor in the event normal operating temperatures

are exceeded. If thermal overload trips due to abnormal operating temperatures, thermal overload shall remain open until manually reset by turning the heater off for 15 minutes. Automatic reset of thermal overloads, which allow the element to continue to cycle under abnormal conditions, will not be accepted. U.S. PATENT #6,748,163 B2 • CIPO PATENT #2,393,882

Ceiling Surface Can: The can shall be 20 gauge electrogalvanized steel and shall contain knockouts. The can shall be provided with a depth gauge, extending the full length of the can. The can shall be supplied with a factory installed groundwire.

Grill: The grill shall be a louvered, one-piece design with rounded edges on all four sides, with rounded corners to prevent snags from contact with other materials. The grill shall be epoxy powder-coated in the color specified by manufacturer.

Approvals: cULus (E41422)

Large Ceiling Heater LPWC Series



Model Code:

LPW	12	27	C
A	B	C	D
A: Series			
B: 12 - 120V 24 - 240V			
20 - 208V 27 - 277V			
C: Watts (1250 to 4500)			
D: C - Ceiling			
G - Ground			



- Pic-A-Watt® element
- Long life unit bearing motor
- 5-Bladed Aluminum fan
- Patented Smart Limit Protection®
- Multiple wattages
- Ceiling mount
- Standard color: white (almond optional)
- 20 gauge powder-coated grill
- 120, 208, 240, or 277 volts
- 5-year limited warranty



Large Pic-A-Watt Ceiling Heater

Designed for commercial and industrial applications, the LPWC offers a high-capacity, heavy-duty ceiling heater where wall space is not available. King's exclusive dual Pic-A-Watt steel fin elements allow customers to select from a range of wattage options, tailoring the heater to an area's specific heating requirements. Available wattages range between 1250 to 4500 watts. It has a fan delay to help dissipate heat from the steel plate fin elements thereby prolonging heater life and increasing energy efficiency.

Ordering Information *Add suffix -W for White Grill or -A for Almond Grill color

	MODEL	VOLTS	WATTS	AMPS	SHIP WEIGHT lbs
120V	LPW1227C	120	1250•1500•1750•2000•2250•2750	10.4-22.9	19 lbs
	LPW1227C	120	1250•1500•1750•2000•2250•2750	10.4-22.9	25 lbs
208V	LPW2040C	208	2250•2750•3000•3250•3500•3750•4000	10.8-19.2	19 lbs
	LPW2040C	208	2250•2750•3000•3250•3500•3750•4000	10.8-19.2	25 lbs
240V	LPW2445C	240	2250•2750•3000•3250•3500•3750•4000•4500	9.4-16.7	19 lbs
	LPW2445C	240	2250•2750•3000•3250•3500•3750•4000•4500	9.4-16.7	25 lbs
277V	LPW2740C	277	2000•3000•4000	7.2-14.4	19 lbs
	LPW2740C	277	2000•3000•4000	7.2-14.4	25 lbs

Options & Accessories

ADD SUFFIX	DESCRIPTION	SHIP WEIGHT lbs
-W	White Color	
-A	Almond Color	
-I	Heatbox Interior and Grill Only (recessed)	15 lbs
-H	Heatbox Interior Only (no can or grill)	15 lbs

MODEL	UPC	DESCRIPTION	SHIP WEIGHT lbs
LPWC-G-W	N/A	T-BAR GRID adapter 2X2 FOR LPWC	6 lbs
UWSA-C	12598	Ceiling Surface Can	7.5 lbs
UWIC-C	12592	Ceiling Recess Can For Advance Install	6.5 lbs

Engineering Specifications

Contractor shall supply and install LPWC Series ceiling-mounted forced-air electric heaters manufactured by King Electrical Mfg. Co. of the wattage and voltage as indicated on the plans.

Motor: Permanently lubricated, unit bearing motor. 20cc of oil. Enclosed motor for long-lasting, trouble-free operation. Thermally protected. 1300 RPM.

Fan: High efficiency, dynamically balanced, 5-bladed aluminum impeller fan. 185 CFM.

Elements: 3 steel sheathed heating tubes in a furnace-brazed, plate-finned, block design containing coiled Ni-Chrome wire embedded in a Magnesium Oxide insulator. Assembly provides up to 7 possible wattage configurations available for field installation selection. The use of external resistors, diodes, or other weak links to obtain multiple wattages will not be accepted.

Thermal Overload: Heaters shall be equipped with King's patented thermal overload Smart Limit Protection, which disconnects elements and motor in the event normal operating temperatures are exceeded. If thermal overload shall remain open until manually reset by turning the heater off for fifteen minutes.

Fan Delay Switch: Fan continues to operate after thermostat shuts off to remove residual heat left in element.

Wall-box: 20 GA electro-galvanized steel. Factory installed ground wire. Zero clearance to insulation. Optional surface box.

Grill: 20 gauge steel finished in a gloss white powder-coated paint.

Approvals: cULus (E41422)

*See LPWC product page for Dimensional Data

Commercial Ceiling Heater KDS Series

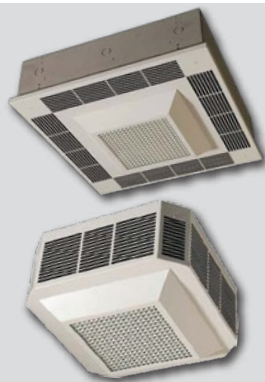

Model Code:

KDS	A	24	20
A	B	C	D

A: Series

B: A=Surface R=Recessed mount

C: 20 - 208V 24 - 240V

27 - 277V 48 - 480V

D: Watts (20=2000 - 100=10000)

E: -1 single phase -3 three phase



- Totally enclosed fan and lifetime-lubricated ball bearing motor
- Three stainless steel tubular heating elements with aluminum fins
- High-limit temperature control with automatic reset
- Fan delay purges heater of residual heat
- Installation recessed into a T-bar ceiling for KDSR units
- Installation surface mounted for KDSA or KDSB units
- Recommended installation height: 8-12 ft. (2.4-3.6m)
- Standard color: white (-BW) (Almond optional)
- Built-in contactor for: all units at 347V, 480V, 600V, all units from 5-10 kW, and all units at 3-Phase
- Continuous circulation controlled by a built in switch (with power-on indicator light (-CV))
- 208V, 240V, 277V, 347V, 480V, 600V, 1 or 3-Phase
- Standard finish: epoxy/polyester powder paint
- Outlet grill made of flat ribbon wire
- 1-year warranty against defects, 10-year on element

The KDS Series Ceiling Heater

Designed for ceiling mount, this unit heater provides a high level of comfort. Driven by a powerful motor, the fan creates circulation by blowing downward warm air accumulation near ceilings.

Engineering Specifications

Contractor shall supply and install KDS Series electric heaters of the wattage and voltage as indicated on the plans.

Color: Standard: white Optional: Almond, metallic silver, bronze, metallic charcoal, aluminum, semi-gloss black. Custom colors available upon request.

Finish: Standard: epoxy/polyester powder paint.

Voltage: 208V, 240V, 277V, 347V, 480V, 600V, 1 or-3 phase.

Construction: Grill made of flat ribbon wire. High-limit temperature control with automatic reset.

Fan: Totally enclosed and lifetime-lubricated ball bearing motor. Fan delay purges heater of residual heat.

Heating element: Three stainless steel tubular heating elements with aluminum fins.

Warranty: 1-year warranty against defects. 10-year warranty on the heating elements.

Control: Line voltage control standard. Built-in 240V contactor for: all units from 5 to 10kW, all units at 347V, 480V, 600V, all units at 3-phase. 24V and 120V control circuit available. Built-in tamperproof thermostat available. 24V relay (with or without transformer) available. Continuous circulation controlled by a built-in switch with power-on indicator light available (-CV). Any remote thermostat or relay must be connected to the heater control terminal block. 4

Installation: Recommended height: between 8 ft. (2.4 m) and 12 ft. (3.6 m). Recessed into insulated or T-bar ceiling (KDSR). Surface mounting (KDSA and KDSB).

Application: Apartment building, commercial building, drop ceiling, stairwell, garage.

Commercial Ceiling Heater KDS Series

Ordering Information *Add suffix -A for optional almond color

	SURFACE MODEL <i>KDSA</i>	UPC	RECESS MODEL <i>KDSR</i>	UPC	SURFACE MODEL <i>KDSB</i>	UPC	VOLTS <i>1ph</i>	WATTS
240V	KDSAU2420-1	30850	KDSRU2420-1	30906			240	2000
	KDSAU2430-1	30852	KDSRU2430-1	30908			240	3000
	KDSAU2440-1	30854	KDSRU2440-1	30910			240	4000
	KDSAU2450-1	30856	KDSRU2450-1	30912			240	5000
					KDSBU2475-1	30962	240	7500
				KDSBU24100-1	30964	240	10000	
208V	KDSAU2020-1	30858	KDSRU2020-1	30914			208	2000
	KDSAU2030-1	30860	KDSRU2030-1	30916			208	3000
	KDSAU2040-1	30862	KDSRU2040-1	30918			208	4000
	KDSAU2050-1	30864	KDSRU2050-1	30920			208	5000
					KDSBU2075-1	30966	208	7500
				KDSBU20990-1	30968	208	9900	
277V	KDSAU2720-1	30866	KDSRU2720-1	30922			277	2000
	KDSAU2730-1	30868	KDSRU2730-1	30924			277	3000
	KDSAU2740-1	30870	KDSRU2740-1	30926			277	4000
	KDSAU2750-1	30872	KDSRU2750-1	30928			277	5000
					KDSBU2775-1	30970	277	7500
				KDSBU27100-1	30972	277	10000	
480V	KDSAU4820-1	30874	KDSRU4820-1	30930			480	2000
	KDSAU4830-1	30876	KDSRU4830-1	30932			480	3000
	KDSAU4840-1	30878	KDSRU4840-1	30934			480	4000
	KDSAU4850-1	30880	KDSRU4850-1	30936			480	5000
					KDSBU4875-1	30974	480	7500
				KDSBU48100-1	30976	480	10000	
	SURFACE MODEL <i>KDSA</i>	UPC	RECESS MODEL <i>KDSR</i>	UPC	SURFACE MODEL <i>KDSB</i>	UPC	VOLTS <i>3ph</i>	WATTS
240V	KDSAU2420-3	30882	KDSRU2420-3	30938			240	2000
	KDSAU2430-3	30884	KDSRU2430-3	30940			240	3000
	KDSAU2440-3	30886	KDSRU2440-3	30942			240	4000
	KDSAU2450-3	30888	KDSRU2450-3	30944			240	5000
					KDSBU2475-3	30978	240	7500
				KDSBU24100-3	30980	240	10000	
208V	KDSAU2020-3	30890	KDSRU2020-3	30946			208	2000
	KDSAU2030-3	30892	KDSRU2030-3	30948			208	3000
	KDSAU2040-3	30894	KDSRU2040-3	30950			208	4000
	KDSAU2050-3	30896	KDSRU2050-3	30952			208	5000
					KDSBU2075-3	30982	208	7500
				KDSBU20990-3	30984	208	9900	
480V	KDSAU4820-3	30898	KDSRU4820-3	30954			480	2000
	KDSAU4830-3	30900	KDSRU4830-3	30956			480	3000
	KDSAU4840-3	30902	KDSRU4840-3	30958			480	4000
	KDSAU4850-3	30904	KDSRU4850-3	30960			480	5000
					KDSBU4875-3	30986	480	7500
				KDSBU48100-3	30988	480	10000	

Commercial Ceiling Heater KDS Series

Dimensional Data

= knockout location

KDSA - Surface 2-5kW, 25 lbs (11.4 kg)

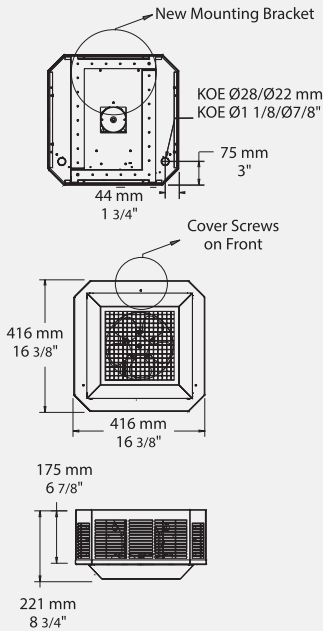

KDSB - Surface 7.5-10kW, 34 lbs (15.5 kg)

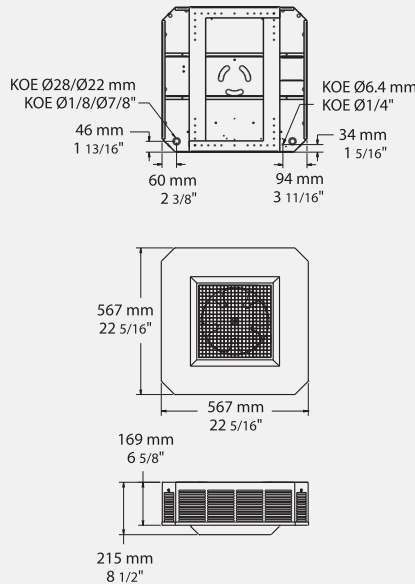

KDSR - Recessed 2-5kW, 31 lbs (14.1 kg)

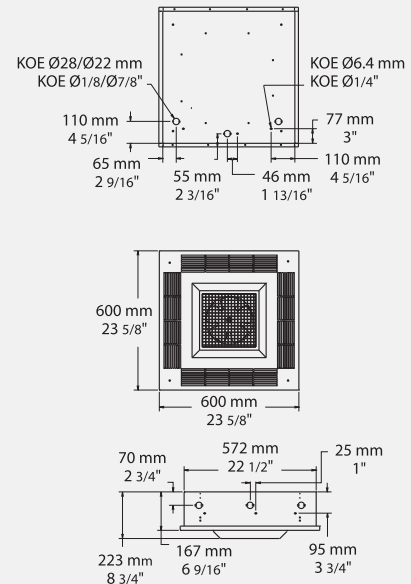

Control Options

MODEL	DESCRIPTION
Product no-RT	Factory installed (Only) 24V relay with transformer
Product no-R	Factory installed 24V relay without transformer
Product no-120	Factory installed 120V control circuit
Product no -RCV24	Factory installed summer fan 24V remote control + pilot light (switch not included)
Product no -RCV240	Factory installed summer fan 240V remote control + pilot light (switch not included)
KDSA-T-BAR KDSB-T-BAR	Adapter for T-bar ceiling (KDSA/KDSB kits)
Product no-CV	Factory installed summer fan switch + pilot light
Product no -DIS20	Factory installed disconnect switch 277V and less, double pole, 20 Amp
Product no -DIS40	Factory installed disconnect switch 600V max, three pole, 40 Amp
Product no -DIS80	Factory installed disconnect switch 600V, three pole, 80 Amp
KDS-T-AV	Built-in tamper-proof thermostat kit
Product #-T-AV	Factory installed built-in tamper-proof thermostat

Options

ADD SUFFIX	DESCRIPTION
-A	Almond color
-AE	Metallic Silver color (10% up-charge applies)
-BZ	Bronze color (10% up-charge applies)
-CM	Metallic Charcoal color (10% up-charge applies)
-AL	Aluminum color (10% up-charge applies)
-NL	Semi-Gloss Black (10% up-charge applies)
-BW	White

Baseboard Heater K Series



Model Code:

4 K 24 10 -BW -HAL
A B C D E F

A: Length
B: Series
C: Volts
D: Watts (375 to 2400)
E: Color (BW) Bright White (A) Almond
F: -HAL (High Altitude Limit)



- Aluminum ribbon fin element
- Full length safety cutout
- Crushproof element
- Natural convection heat
- Back wire design
- Built-in clamps coming soon
- Baked enamel finish
- Dent resistant die form cover
- 120, 208, 240 or 277 volts
- Standard color: bright white (optional almond color)
- 1-year limited warranty

The K Series Baseboard Heater

Baseboard heaters are an economical way to provide heat. They are typically used in apartment construction and other rental properties because of low initial cost and maintenance. Quality components guarantee a long-lasting, reliable heater. Standard color is bright white. Almond color available. Institutional grade 18 gauge front covers and 22 gauge back cans are available for special applications. All other specifications are the same as the standard heater.

Dimensional Data Standard Backwire Junction Box

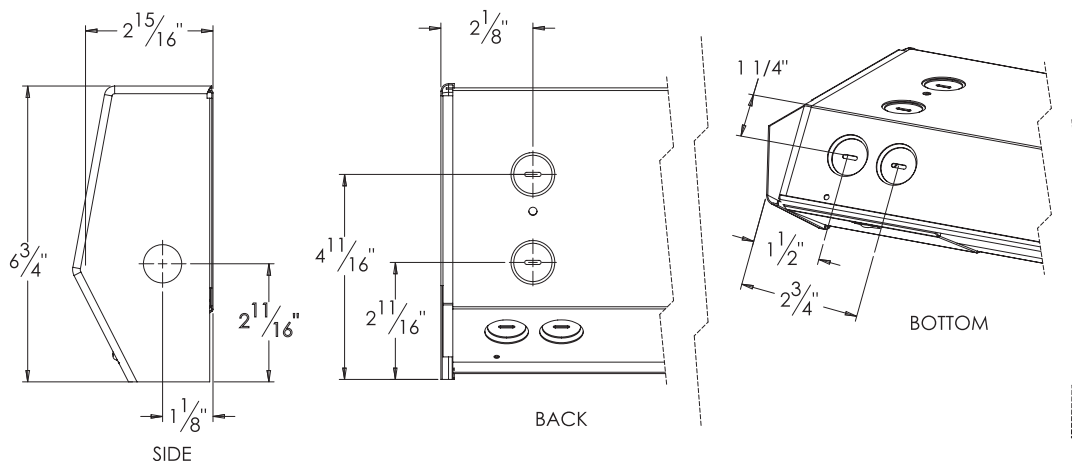

Engineering Specifications

Contractor shall supply and install K Series electric convection baseboard heaters manufactured by King Electrical Mfg. Company of the wattage, voltage and length indicated on the plans.

Construction:

- The heater shall take room air in the bottom (lower front) and discharge it through the top front.
- The heater back, bottom, and top shall be fabricated from electro-galvanized 22 gauge steel. Front panels shall be fabricated from 22 gauge electro-galvanized steel, ribbed longitudinally for extra strength and have center support to resist impact loads.
- The heater casing shall have modern rounded ends and corners to provide a smooth appearance, finished with a baked enamel.
- The heater shall be provided with a continuous capillary sensor tube for thermal protection, extending the full length of the heating element, rated at 175° F, and be a fail-safe type.

- The heater shall have a 44 cubic inch junction box at both ends, furnished with five 1/2" knockouts located on the back, bottom, and side.
- Heater elements shall consist of high quality 80% Nickel and 20% Chromium alloy corrosion-resistant wire completely surrounded by Magnesium Oxide and enclosed in a rust-resistant sheath. Ribbon aluminum finning shall be compression welded to the sheathed element to provide chimney-type flue for heat transfer.
- Heaters shall be supplied with a one year limited warranty.

Rating and Approval:

- The heaters shall be available in ratings from 375 through 1,500 Watts at 120 Volts, and 375 to 2,400 Watts at 208-240 and 277 Volts.
- The heaters shall be available in 187 or 250 Watts per lineal foot.
- cULus (E29778)

Baseboard Heater K Series

Ordering Information Standard models Add suffix BW for bright white color and A for optional almond color.

	MODEL	VOLTS	WATTS	AMPS	LENGTH	SHIP WEIGHT lbs
120V	2K1205	120	500	4.2	27"	6.5
	3K1207	120	750	6.3	3 ft.	8
	4K1210	120	1000	8.3	4 ft.	10.5
	5K1212	120	1250	10.4	5 ft.	13
	6K1215	120	1500	12.5	6 ft.	15
208V	2K2005	208	500	2.4	27"	6.5
	3K2007	208	750	3.6	3 ft.	8
	4K2010	208	1000	4.8	4 ft.	10.5
	5K2012	208	1250	6.0	5 ft.	13
	6K2015	208	1500	7.2	6 ft.	15
240V	8K2020	208	2000	9.6	8 ft.	19
	8K2024	208	2400	11.5	8 ft.	19
	2K2405	240/208	500/375	2.1/1.8	27"	6.5
	3K2407	240/208	750/563	3.1/2.7	3 ft.	8
	4K2410	240/208	1000/750	4.2/3.7	4 ft.	10.5
277V	5K2412	240/208	1250/938	5.2/4.5	5 ft.	13
	6K2415	240/208	1500/1125	6.3/5.5	6 ft.	15
	8K2420	240/208	2000/1500	8.3/7.2	8 ft.	19
	8K2424	240/208	2400/1800	10.0/8.7	8 ft.	19
	2K2403	277	500	1.8	27"	6.5
277V	3K2405	277	750	2.7	3 ft.	8
	4K2407	277	1000	3.6	4 ft.	10.5
	5K2410	277	1250	4.5	5 ft.	13
	6K2412	277	1500	5.4	6 ft.	15
	8K2415	277	2000	7.2	8 ft.	19
	8K2418	277	2400	9.0	8 ft.	19

Ordering Information *Low Density: 187 Watts per foot Add suffix BW for bright white color and A for optional almond color.

	MODEL	VOLTS	WATTS	AMPS	LENGTH	SHIP WEIGHT lbs
	2K2405	208	375	1.8	27"	6.5
	3K2407	208	563	2.7	3 ft.	8
	4K2410	208	750	3.6	4 ft.	10.5
	5K2412	208	938	4.5	5 ft.	13
	6K2415	208	1125	5.4	6 ft.	15
	7K2418	208	1313	6.3	7 ft.	19
	8K2420	208	1500	7.2	8 ft.	19
	8K2424	208	1800	9.0	8 ft.	19
	2K2403	240	375	1.6	27"	6.5
	3K2405	240	563	2.3	3 ft.	8
	4K2407	240	750	3.1	4 ft.	10.5
	5K2410	240	938	3.9	5 ft.	13
	6K2412	240	1125	4.7	6 ft.	15
	8K2415	240	1500	6.3	8 ft.	19
	8K2418	240	1800	7.8	8 ft.	19

Factory Installed Options

ADD SUFFIX	DESCRIPTION	SHIP WEIGHT lbs
BW	Bright White Color	0
A	Almond Color	0
-HAL	High Altitude Limit	N/A
-BK	Optional Backwire Junction Box	N/A

Optional Backwire Junction Box

Technical drawings of the optional backwire junction box. Dimensions include: 3 3/16" (width), 6 3/4" (height), 1 1/8" (base width), 2 3/4" (top width), 2 1/8" (top offset), 1 1/2" (top offset), 1 1/2" (top offset), 2 7/8" (bottom offset), and 4 5/8" (bottom offset). A knockout is labeled as $\phi 7/8$ KNOCKOUTS.

Crush Proof Design

Crush Proof Design diagram showing the internal components: Advanced Ribbon Finning Bonded to Metal Sheath, MgO Packed Element, and Coiled Nichrome Wire.

Baseboard Heater Accessories K & CB Series

Accessories

MODEL	UPC	DESCRIPTION	SHIP WEIGHT lbs
BKC-BW	11474	Corner Connector - Bright White, inside cover	1.5
BKR120-BW	11494	Duplex Cover Plate (includes 120V receptacle) - Bright White (See below)	0.5
BKLT120-BW*	11481	Load Transfer Cover Plate (Heat/Cool/Off) 120V - Bright White	0.5
BKLT240-BW*	11483	Load Transfer Cover Plate (Heat/Cool/Off) 240V - Bright White	0.5
BKCB1-BW	11532	3-3/4" Relay Control Box - Bright White	1.5
BKCB2-BW	11534	7-1/8" Dual Relay Control Box - Bright White	3.0
BKT1BW	11484	Built-In Thermostat Kit (SPST) - Bright White (5 Pack)	0.6
BKT1BW-TP	11542	Built-In Tamperproof Stat Kit (SPST) - Bright White (5 Pack)	0.3
BKT2BW	11488	Built-In Thermostat Kit (DPST) - Bright White (5 Pack)	0.5
BKT2BW-TP	11544	Built-In Tamperproof Stat Kit (DPST) - Bright White (5 Pack)	0.6
-HAL	N/A	High Altitude Limit for Baseboards used over 7000 feet	N/A
BKT-TIMER3HR-BW	11487	3 Hour spring wound timer/wire leads 16 amp/250 Vac. 15 Amp/125 Vac.	0.6

*Requires BKCB1 Control box, order separately.

Shield Options * Specify Color: Almond or White NON Cancel-able - NON Returnable item (NCNR)

MODEL	UPC	DESCRIPTION	SHIP WEIGHT lbs
SHIELD-33"	10290	Heater Shield for 27" Baseboard	6
SHIELD-42"	10291	Heater Shield for 3' Baseboard	7
SHIELD-54"	10292	Heater Shield for 4' Baseboard	8.5
SHIELD-66"	10293	Heater Shield for 5' Baseboard	10
SHIELD-78"	10294	Heater Shield for 6' Baseboard	11
SHIELD-102"	10295	Heater Shield for 8' Baseboard	14

Cover Options * Specify Color: Almond or White NON Cancel-able - NON Returnable item (NCNR)

MODEL	UPC	DESCRIPTION	SHIP WEIGHT lbs
BB-18ga Cover 2'	52054	18 Gauge Cover for 27" Baseboard	1.5
BB-18ga Cover 3'	52056	18 Gauge Cover for 3' Baseboard	2
BB-18ga Cover 4'	52058	18 Gauge Cover for 4' Baseboard	2.6
BB-18ga Cover 5'	52060	18 Gauge Cover for 5' Baseboard	3.65
BB-18ga Cover 6'	52062	18 Gauge Cover for 6' Baseboard	4
BB-18ga Cover 8'	52064	18 Gauge Cover for 8' Baseboard	5.3

Thermostats, Options & Accessories

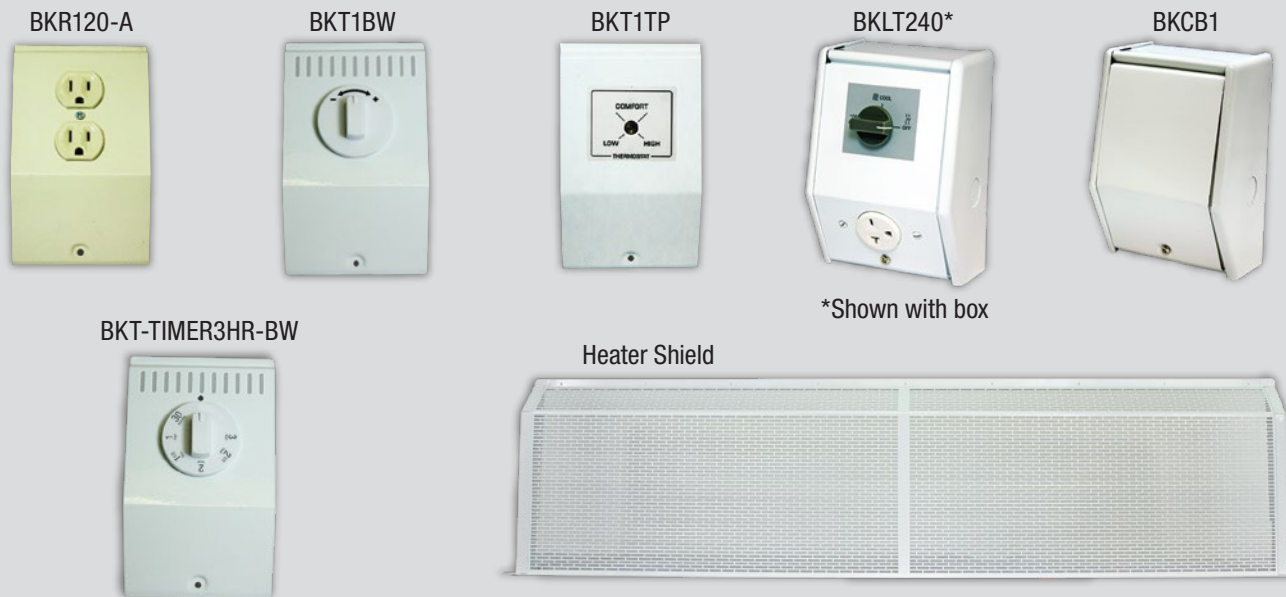

Ceramic Core Baseboard Heater CB Series



Model Code:

2	CB	240	03	BW	-HAL
A	B	C	D	E	F

A: Length
B: Series
C: 12 - 120V 24 - 240V 20 - 208V
D: Watts (350 to 1500)
E: Color (BW) Bright White (A) Almond
F: -HAL (High Altitude Limit)



- High mass ceramic heating-core
- Natural convection heat
- Low density heat
- Quiet running
- Fluid-free design
- Standard color: bright white (optional almond color available)
- Available in three voltages 120V / 208V / 240V
- 5 year limited warranty



The CB Ceramic Core Baseboard Heater

King's premium ceramic baseboard has over 55 years of proven reliability and performance. The high mass ceramic element design far exceeds the performance of a standard baseboard with thermal storage from the ceramic core and more efficient heat transfer from oversized aluminum fins. The result is more gentle heating with fewer on/off cycles as the ceramic core slowly heats up and then continues to dissipate heat during the off cycle. Lower surface temperatures and reduced watt density making the heater much safer. A better alternative to water or oil-filled baseboard heaters that can leak due to high pressure created when heating the fluid in a self-contained vessel.

Ordering Information * Add suffix (-A) for optional Almond finish Note: Over 8500 ft Altitude 210 degree high limits will need to be used.

	MODEL	VOLTS	WATTS	AMPS	LENGTH	SHIP WEIGHT lbs
120V	2CB1203	120	350	2.9	27"	7
	3CB1205	120	500	4.2	3 ft.	8
	4CB1207	120	750	6.3	4 ft.	10.5
	5CB1210	120	1000	8.3	5 ft.	13
	6CB1212	120	1250	10.4	6 ft.	16
	208V	2CB2003	208	350	1.7	27"
3CB2005		208	500	2.4	3 ft.	8
4CB2007		208	750	3.6	4 ft.	10.5
5CB2010		208	1000	4.8	5 ft.	13
6CB2012		208	1250	6.0	6 ft.	16
240V		8CB2015	208	1500	7.2	8 ft.
	2CB2403	240	350	1.5	27"	7
	3CB2405	240	500	2.1	3 ft.	8
	4CB2407	240	750	3.1	4 ft.	10.5
	5CB2410	240	1000	4.2	5 ft.	13
	6CB2412	240	1250	5.2	6 ft.	16
	8CB2415	240	1500	6.3	8 ft.	20.5

*Refer to accessories page for options

Factory Installed Options

ADD SUFFIX	DESCRIPTION	SHIP WEIGHT lbs
BW	Bright White Color	0
A	Almond Color	0
-HAL	High Altitude Limit	N/A
-BK	Optional Backwire Junction Box	N/A

Dimensional Data

See Pg 36 for Standard Backwire Junction Box

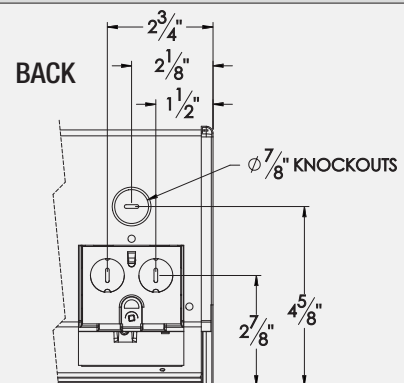
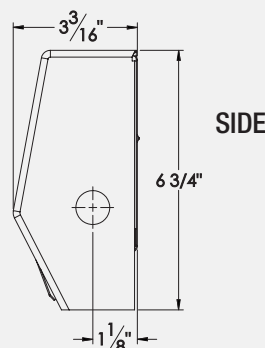
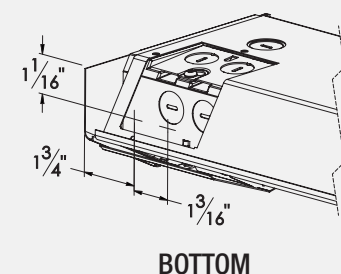

Ceramic Core Baseboard Heater CB Series

Engineering Specifications

Contractor shall supply and install CB ceramic baseboard heaters, manufactured by King Electrical Mfg. Company. Heaters shall be of the wattage and voltage as indicated on the plans.

Typical Application: The rugged construction makes this a very durable heater suitable as a primary heat source for everyday use.

Element: The superior performance comes from the proven technology of the ceramic heater core. A 7/8" diameter aluminum tube is filled with a special high density ceramic that stores the thermal energy. The oversized fins (4.875 in²) are made from durable (0.015" thick) high grade aluminum which produces better heat transfer than other elements. The benefit of the technology comes when the thermostat is turned off and the element continues to radiate heat. It also reduces temperature swings by heating and cooling more evenly.

Safety: The large heating element and low watt density produce low surface temperatures making it very safe.

Thermal Cutout: A continuous capillary sensor extends the full length of the baseboard, turning the element off when an over temperature

condition occurs. Automatically resets when the normal temperature returns. Optional manual reset available.

Construction: Expansion noise is eliminated by welding the junction boxes and element hangers to the baseboard case. 22 gauge steel adds strength across the entire length of the baseboard.

Quick Wiring: Identical junction boxes with knockouts in the rear, side and bottom allow the baseboard to be wired from either end. One screw makes quick access to the wiring compartment.

Exterior: Durable baked enamel finish. Colors include standard bright white with almond as an option. Custom colors are available upon request. Commercial Construction: Optional 18 gauge front cover for commercial use.

Options: Single Pole or Double Pole unit-mount thermostat 45°-80°F.

Quiet: The low temperature element heats cleanly and quietly.

Warranty: 5 year product warranty.

Approvals: cULus (E29778)



Over 55 years of Proven Performance

CB Baseboards Can Save Money on Your Heating Bills!

Ceramic Core Element (Liquid-Free Design)

The CB baseboard produces quiet convection heat with fewer on/off cycles as the ceramic core slowly heats up and then continues to dissipate heat during the off cycle which dramatically reduces the temperature swings associated with standard electric baseboards. Every one degree decrease in the thermostat setting results in approximately a 3% decrease in energy savings. The CB baseboard enables you to feel comfortable at a lower thermostat setting which can result in a 3% to 5% saving on your energy bills.

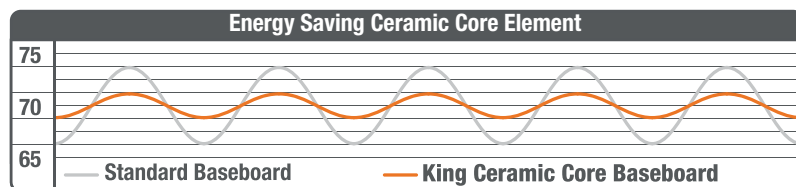

*Reduces temperature swings

When combined with an electronic thermostat the saving can be over 10% as the temperature swing will be decreased even more. The optimum results of up to 25% savings can be achieved with the CB heater and a programmable thermostat that will turn the temperature down automatically at bedtime and while you are away. (Refer to King's broad selection of electronic line voltage thermostats)

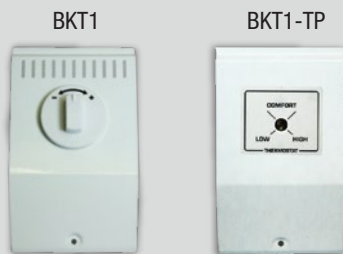
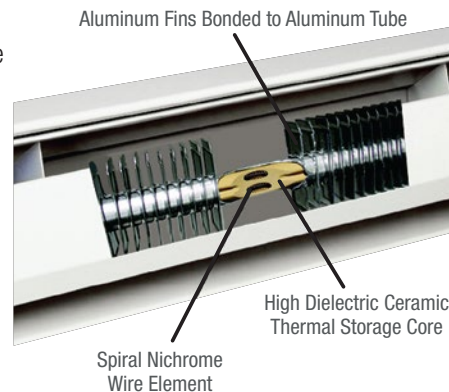

Ceramic Core Element Diagram

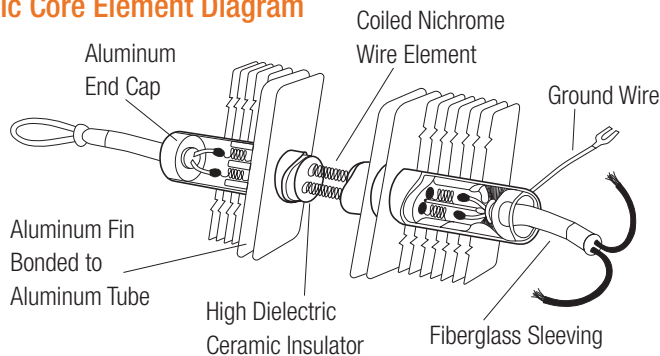

Cove Heater KCV Series

Model Code:

KCV	12	10
A	B	C
A: Series		
B: 12 - 120V 20 - 208V		
24 - 240V		
C: Watts (210 - 1800)		



- Radiant & Convection Heat
- Long Life Elements
- Silent Running
- Junction box at each end
- Extruded aluminum front panel
- Powder coated high temp. finish
- Easy surface-mount installation
- Ribbed front for maximum surface radiation
- Open-back design for maximum convection
- 1/2" diameter knockouts for 1/2" conduit
- Standard color: almond (white optional)
- 2-year limited warranty



The KCV Series Cove Heater

The KCV cove heater is a radiant heater that also produces convection heat by heating the air similar to a baseboard. By combining the quick comfort of radiant heat along with the sustained warmth of convection heat, warm air is uniformly dispersed throughout the room. The cove heater is mounted near the ceiling, eliminating furniture placement problems. Surface temperatures are lower than baseboard or fan heaters, making a pleasant form of heat similar to older ceiling cable heating systems. With no moving parts this heater is quiet and maintenance free. Typical uses are day care centers, assisted living housing, housing developments, laundry rooms, bathrooms, bedrooms.

Ordering Information * Add suffix -W for White or -A for Almond

	MODEL	VOLTS	WATTS	AMPS	LENGTH	SHIP WEIGHT lbs
120V	KCV1202	120	210	1.8	24"	5.5
	KCV1204	120	420	3.5	34"	6.7
	KCV1206	120	560	4.7	47"	9.3
	KCV1207	120	700	5.8	59"	11.2
	KCV1209	120	840	7.0	71"	11.2
	KCV1210	120	935	7.8	83"	15.3
	KCV1212	120	1125	9.4	94"	16.8
	KCV1215	120	1400	11.7	118"	26.0
208V	KCV2004	208	420	2.0	34"	6.7
	KCV2006	208	560	2.7	47"	9.3
	KCV2007	208	700	3.4	59"	11.2
	KCV2009	208	840	4.0	71"	13.1
	KCV2010	208	935	4.5	83"	15.3
	KCV2012	208	1125	5.4	94"	16.8
	KCV2015	208	1400	6.7	118"	21.2
	KCV2018	208	1800	8.7	118"	21.2
240V	KCV2404	240/208*	420/315	1.8/1.5	34"	6.7
	KCV2406	240/208*	560/420	2.3/2.0	47"	9.3
	KCV2407	240/208*	700/525	2.9/2.5	59"	11.2
	KCV2409	240/208*	840/630	3.5/3.0	71"	13.1
	KCV2410	240/208*	935/701	3.9/3.4	83"	15.3
	KCV2412	240/208*	1125/844	4.7/4.0	94"	16.8
	KCV2415	240/208*	1400/1050	5.8/5.0	118"	26.0
	KCV2418	240/208*	1800/1350	7.5/6.5	118"	26.0

*Dual rated heaters will draw 13% less amps and 25% less wattage when operated at 208V.

Cove Heater KCV Series

Accessories/Options

MODEL	DESCRIPTION	SHIP WEIGHT lbs
KCVT-1R	Single Pole Right side wiring thermostat	.25
KCVT-1L	Single Pole left side wiring thermostat	.25
KCVT-2R	Double Pole Right side wiring thermostat	.25
KCVT-2L	Double Pole Left side wiring thermostat	.25
-04-09	Joint Cover (To Combine 2 KCVs) Almond	.09
-04-09-W	Joint Cover (To Combine 2 KCVs) White	.09
-W	White	
-A	Almond	

Engineering Specifications

Construction:

- Constructed of extruded aluminum with a maximum cross section thickness of .962".
- With sawtooth profile to increase radiating surface area.
- Open on top and bottom for maximum convection heating room air.
- With 32 cubic inch junction box at both ends, furnished with 1/2" knockouts on back and top.
- Ni-Chrome wire embedded in Magnesium Oxide powder enclosed and sealed in aluminum sheath.

- Element wattage density of approximately 150 watts per linear foot.
- With full length back case constructed of 22 gauge electrogalvanized steel with baked enamel finish.
- Two year limited warranty.

Ratings and Approvals:

- The heaters shall be available in ratings from 250 - 1800 watts at 120 and 208/240 Volts.
- cULus

Dimensional Data

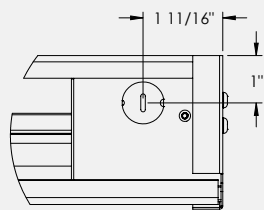

TOP VIEW
DETAIL B
SCALE 1 : 2

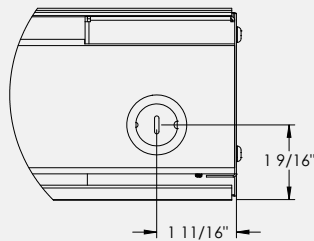

BACK VIEW
DETAIL C
SCALE 1 : 2

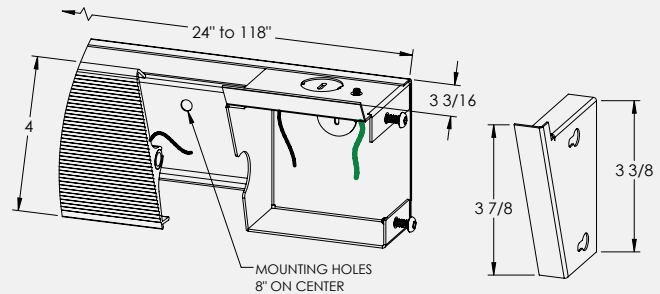

DETAIL A
SCALE 1 : 2

MINIMUM CLEARANCE

Heaters are not to be mounted closer than 2 1/2" from drywall ceiling or 6" from vinyl or drop ceiling. Heaters to be mounted at least 6 feet from floor.

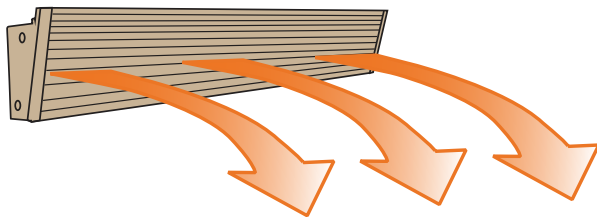

Radiant:
Heat produced is emitted as radiant infrared invisible rays

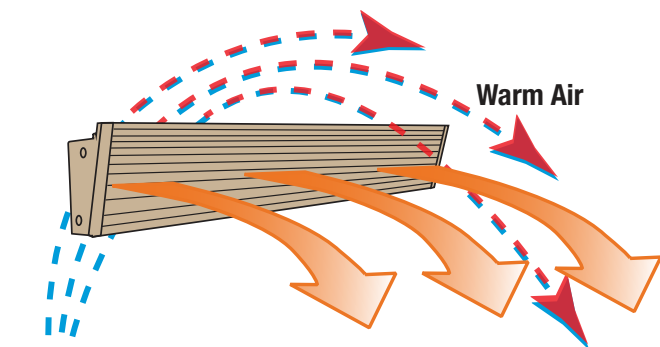

Convection:
Heat produced is also transmitted by natural convection from the top of the heater

WiFi Elec. Prog. Thermostat ATMOZ WiFi Series



Wifi **ATMOZ**



- Programmable with Atmoz Smart Phone App
- Single or double pole line voltage
- Back-lit display for easy viewing
- Temperature range 41° - 90°F (5° - 32°C)
- Program 4 or 6 time periods for maximum flexibility

- Electronic sensing for accurate temperature control ($\pm 1^\circ\text{F}$)
- For use on baseboard, fan forced & radiant electric heaters
- Large back-lit buttons allow easy adjustment & programming
- Mounts directly to a 2x4 inch vertical electrical outlet box

Wifi



The ATMOZ WiFi Enabled Thermostat & Smart Phone App

Wifi Enabled: King's Atmoz WiFi enabled thermostat combines the latest technology with a sleek modern design, offering unparalleled user control. It's highly accurate sensing technology saves up to 28% on heating costs. This feature achieves higher comfort levels with reduced temperature swings as compared to economy models. With its simple, intuitive smart phone app interface you can control all thermostats in your home with ease. Control is always in the palm of your hands.

Ordering Information

MODEL	UPC	DESCRIPTION
ATMOZ1-240-WIFI	10396	1P WIFI Programmable Electronic Thermostat, 240V
ATMOZ2-240-WIFI	10397	2P WIFI Programmable Electronic Thermostat, 240V

Engineering Specifications

Temperature Range: 41° - 90°F (5° - 32°C) **Accuracy:** +1° F
Max Power: 3328W @ 208VAC (16A)
Max Power: 3840W @ 240VAC (16A)
Sensing Element: Electronic



Smart Phone iPhone or Android App



- ✓ Connect Via WIFI For Convenient Programming & Use
- ✓ Easy To Navigate Menus For Quick Programming
- ✓ Control Multiple Thermostats For Total Home Control
- ✓ Available for Android and iOS.

Wifi



WiFi Elec. Prog. Thermostat ATMOZ WiFi Series

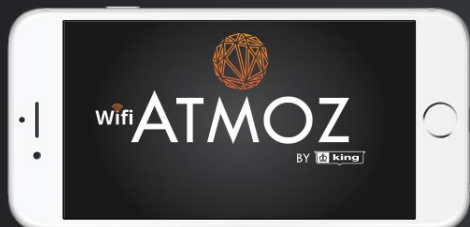

In-Home mobility

Convenient **Wifi** connectivity allows for total user comfort throughout the home. Control from anywhere with cell service or Wifi. With the **ATMOZ** smart phone app, you can adjust the temperature of your thermostat from the comfort of the couch. The climate of your home will become a customized atmosphere that you control, or let **ATMOZ** do it for you.



Comfort just a click away

The **ATMOZ** menu & interface were designed to create an excellent experience for all users. Including password protection to block unauthorized users from making unwanted changes. Each menu is easy to navigate and includes large buttons, allowing for quick and simple programming of all your custom settings. Making changes is no longer a hassle. Going on vacation, simply pre-schedule your Vacation Mode Settings. With **ATMOZ**, your home is in good hands.



Infinite possibilities

While using **ATMOZ**, total home control becomes your reality. The app allows the user to control multiple thermostats, with no limit, throughout the home. **ATMOZ** thermostats are programmable with up to six time periods in a day. By selecting Boost Mode, the current period can be extended up to 3 additional hours, without altering the programmed schedule. Let **ATMOZ** find new possibilities in your home.

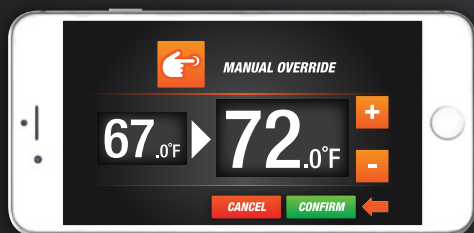

Changes made easy

Manually override your programmed settings at any time with the app or directly through the thermostat. Your presets will still retain the same settings, and the override temperature will only remain until the end of the current period. However, by activating Hold Mode, you can lock the current temperature for any duration until manually changed. **ATMOZ** gives your home the comfort that you deserve.

Electronic Prog. Thermostat CLEAR TOUCH Series



K302PE



K312RELAY

- 7 day programmable
- Modern design with clear Acrylic panel
- Touch sensitive buttons
- Large LCD display with blue backlight
- Temperature lock feature: set a min & Max temp limit
- Save up to 28% on your heating costs
- 3 minute cycle rate reduces temperature swings
- Complies with all codes requiring anticipated/electronic thermostats
- System On/Standby switch



The ClearTouch™ Electronic 7 Day Programmable Thermostat

King's ClearTouch K302PE combines user-friendly touch sensitive buttons with a sleek modern design, offering unparalleled user comfort control. ClearTouch is an energy-saving fully programmable solution for providing highly accurate temperature control for line voltage electric heaters. It's highly accurate sensing technology saves up to 28% on heating costs. Program a full 7 day schedule with ease for total room control.

Ordering Information

MODEL	UPC	DESCRIPTION
K302PE	10399	Thermostat Programmable DP 120/208/240V 15A
K312RELAY	10400	Thermostat Slave Relay DP 120/208/240V 15A

Engineering Specifications

Temperature Range: 41° - 95°F (5° - 35°C) **Accuracy:** +1° F
Max Power: 1800W @ 120VAC (15A)
Max Power: 3120W @ 208VAC (15A)
Max Power: 3600W @ 240VAC (15A)
Sensing Element: Electronic



Want To Control Multiple Heaters?

K302PE thermostats are compatible with K312RELAY (Shown Below) to extend the heating zone beyond 15A & control from one master location.

ClearTouch™



K312RELAY

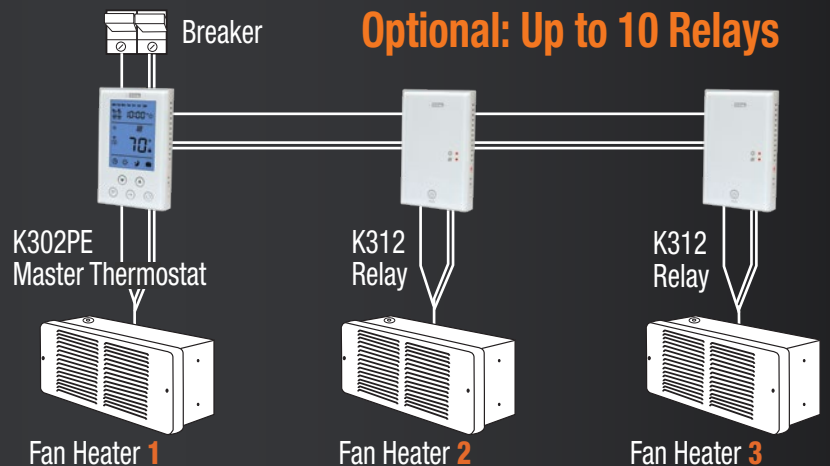

Optional: Up to 10 Relays

- Add up to 10 Relays to extend the heating zone
- Settings controlled by master thermostat
- Receives signal & activates heat when required
- ♦ ON/STANBY switch to disable heating independently

Electronic Non-Prog. Thermostat CLEAR TOUCH Series



K322E



K312RELAY

- Simple Up & Down temperature selection
- Electronic sensing for accurate temperature control ($\pm 1^\circ\text{F}$, $\pm 0.5^\circ\text{C}$)
- Modern design with clear Acrylic panel
- Touch sensitive buttons
- Large LCD display with blue backlight
- Temperature lock feature: set a min & Max temp limit
- Save up to 15% on your heating costs
- 3 minute cycle rate reduces temperature swings
- Complies with all anticipated/electronic codes
- System On/Standby switch
- Dual Voltage – 120V or 208/240V



The ClearTouch™ Non-Programmable Electronic Thermostat

King's ClearTouch K322E combines user-friendly touch sensitive buttons with a sleek modern design, offering simple control of a room's temperature. ClearTouch's electronic sensing, provides highly accurate temperature control ($\pm 1^\circ\text{F}$, $\pm 0.5^\circ\text{C}$) for line voltage electric heaters, saving up to 15% on your heating costs.

Ordering Information

MODEL	UPC	DESCRIPTION
K322E	40360	Thermostat Non-Programmable 120/208/240V 15A
K312RELAY	10400	Thermostat Slave Relay DP 120/208/240V 15A

Engineering Specifications

Temperature Range: 41° - 95°F (5° - 35°C) **Accuracy:** +1° F
Max Power: 1800W @ 120VAC (15A)
Max Power: 3120W @ 208VAC (15A)
Max Power: 3600W @ 240VAC (15A)
Sensing Element: Electronic



Want To Control Multiple Heaters?

K322E thermostats are compatible with K312RELAY (Shown Below) to extend the heating zone beyond 15A & control from one master location.

ClearTouch™

LIMITED
1 Year
Warranty



K312RELAY

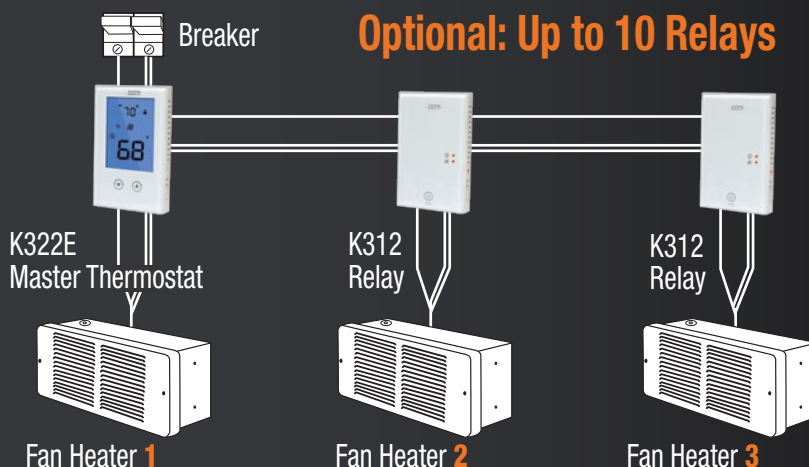

Optional: Up to 10 Relays

- Add up to 10 Relays to extend the heating zone
- Settings controlled by master thermostat
- Receives signal & activates heat when required
- ON/STANBY switch to disable heating independently

Personalized Presets SIMPLSTAT Series



SIMPLSTAT



- 3 programmable presets (Home / Away / Sleep)
- Single pole battery powered or double pole line voltage
- Large back-lit Display for easy viewing
- Temperature range 41° - 95°F (5° - 35°C)
- Clean, beveled style suits any décor
- Electronic sensing for accurate temperature control ($\pm 1^\circ\text{F}$)
- For use on baseboard, fan forced & radiant electric heaters
- Large back-lit buttons allow easy temperature adjustment
- Fully vented cover allows air sensing in all directions
- Mounts directly to a single gang vertical electrical outlet box
- 1-year limited warranty

The SIMPLSTAT Electronic Thermostat with Personalized Presets

No Programming Required. Featuring a user-friendly interface of 3 oversized, back-lit preset temperature buttons that can be personalized (Home / Away / Sleep). Simply press the custom comfort preset button that applies and have confidence that the room will reach optimal temperature within minutes. Combining industry leading temperature sensing technology with a modern sleek design, King's K700E series achieves lower energy consumption with higher comfort levels by reducing temperature swings as compared to economy models.

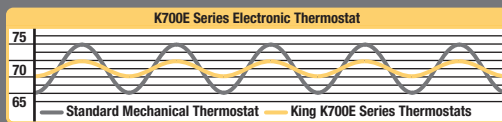

Ordering Information

MODEL	UPC	DESCRIPTION
K702E-2	10393	208/240V, 2P Line Voltage Electronic Thermostat
K701E-B	10392	120/208/240V, 1P AA Battery Powered Electronic Thermostat (Batteries included)

Engineering Specifications

Temperature Range: 41° - 95°F (5° - 35°C) **Accuracy:** $\pm 1^\circ\text{F}$
Max Power: 1920W @ 120VAC (16A) *K701E-B Only
Max Power: 3328W @ 208VAC (16A)
Max Power: 3840W @ 240VAC (16A)
Sensing Element: Electronic



SIMPLSTAT Interface

Push Button To Select Status



Home

70°



Away

55°



Sleep

60°

*Default Settings

Simple, Real-Time Control. Simply press the custom comfort temperature button that applies and have confidence that the room will reach optimal temperature within minutes. Right out of the box, use the factory-default temperatures or personalize by simply updating the defaults with new personalized comfort settings.



Electronic Thermostat ES120/ES230/ESP230



**ES120
ES230**
Non Programmable



ESP230
Programmable



Dimensional Data

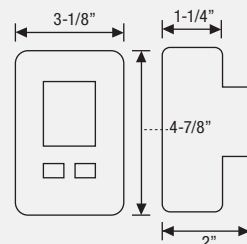

- ES saves up to 15% on your heating costs
- ESP saves up to 28% on your heating costs
- Even temperature control
- 3-wire installation
- LCD display of room temperature
- Red LED heater ON indicator
- Comfort color back light display (Red at 75°F / Blue at 65°F)

- Electronic temperature sensing is the most accurate technology
- 3 minute cycle rate reduces temperature swings and increases comfort at all control settings
- Complies with all codes requiring anticipated or electronic thermostats
- Single pole design with third wire to power display
- Shallow design allows more wiring room inside full electrical boxes
- Available in 120V or 208/240V
- System On/Off switch

- 1 year warranty

Ordering Information

MODEL	UPC	TYPE	WIRE LEADS	VOLTS	AMPS	TEMP. RANGE
ES120-R	10372	Electronic Line Voltage	3 Wire	120	22	40°F-95°F
ES230-R	10374	Electronic Line Voltage	3 Wire	208/240	22	40°F-95°F
ESP120-R	10378	7-Day Programmable	3 Wire	120	22	44°F-95°F
ESP230-R	10380	7-Day Programmable	3 Wire	208/240	22	44°F-95°F

The ES Electronic Thermostat

This line voltage thermostat is one of-a-kind in features then improved with memory backup for power outages. All the features you want with only two buttons. Simple has always been better. Two keys on the front control the temperature up and down. With comfort color back lighting and an on/off switch to control the illumination and system. Comfort color back light display is blue at 65°F and red at 75°F and varies in color between making it quick and easy to know your temperature. The illuminated LCD display can be read across the room making it easy to see at night. Simple, accurate control is the goal of the ES model. No fancy programming, just dependable temperature control for your home, saving money on your heating bills.

ES Technical Specifications

- Temperature Range:** 40°F - 95°F (4°-35°C)
- Temperature Default:** Your saved setting
- Display Format:** LCD
- Illumination:** Blue/Red LED
- Sample Rate:** Every 60 seconds
- Room Temp. Display:** Large LCD
- Delay:** 3 minutes on or off
- Accuracy:** NEMA TEST 1.5°F @ 22 Amps, 1.4°F @ 16 Amps, 1.2°F @ 10 Amps, 0.9°F @ 4.2 Amps
- Power Source:** 120 VAC (ES120), 208/240 VAC (ES230), 50 - 60Hz
- Battery Backup**
 - 22 Amps at 240V, 5280 Watts
 - 22 Amps at 208V, 4576 Watts
 - 22 Amps at 120V, 2640 Watts
 - Wire leads #12 AWG
 - 40°F to 95°F set point range
 - Electronically anticipated
- 120V or 208/240V models only
- Digital thermometer/set point
- Meets energy requirements
- Three wire installation
- Snap action relay built-in
- 30 Amp relay
- 3 min. delay between cycles
- For use on all types of electric heaters, fan-forced, baseboard, radiant, etc.
- Single button operation
- Thermistor sensor
- Contemporary styling
- LCD display
- 1.5 degrees maximum
- 3/4" depth into wire box
- On/Off switch for back light
- On/Off switch for system

The ESP Electronic Programmable

This thermostat took years to develop and has become a popular model. All the features you want without too many buttons. Simple is always better. We have added backlighting to the full-size display and an on/off switch to control the illumination. On the front two simple buttons control the temperature up and down, while all the programming keys are hidden under the front cover, protected from wandering, unauthorized fingers. Comfort and convenience is always our primary goal at King.

ESP Technical Specifications

- Temperature Range:** 44°F - 95°F (7°-35°C)
- Temperature Default:** Your saved setting
- Display Format:** LCD
- Illumination:** Green LED
- Sample Rate:** Every 60 seconds
- Room Temp. Display:** Large LCD
- Delay:** 3 minutes on or off
- Accuracy:** NEMA TEST 1.5°F @ 22 Amps, 1.4°F @ 16 Amps, 1.2°F @ 10 Amps, 0.9°F @ 4.2 Amps
- Power Source:** 208/240 VAC (ES230), 50 - 60Hz
- 22 Amps at 240V, 5280 Watts
- 22 Amps at 208V, 4576 Watts
- 22 Amps at 120V, 2640 Watts
- Wire leads #12 AWG
- 44°F to 95°F set point range
- Electronically anticipated
- 120V or 208/240V models only
- Digital thermometer/set point
- Meets energy requirements
- Three wire installation
- Snap action relay built-in
- 30 Amp relay
- 3/4" depth into wire box
- Single button operation
- Thermistor sensor
- Contemporary styling
- LCD display
- 1.5 degrees maximum
- 3 min. delay between cycles
- For use on all types of electric heaters, fan-forced, baseboard, radiant, etc.
- On/Off switch for backlight
- On/Off switch for system
- Battery backup

Programmable Thermostat WR/WRP

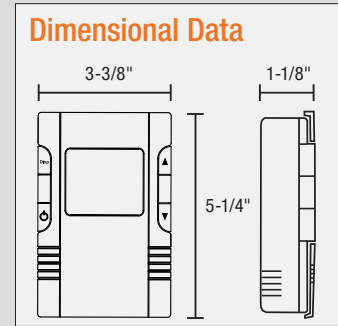

- **Models available:**
 - WR230: simple electronic thermostat
 - WRP230: adds 7 day programming
- Temperature range: 40° to 75°F (4° - 24°C)
- Power failure Restart: occupant's set point
- Display Format: Liquid Crystal Display (LCD)
- Remote-Controlled Set Back: yes (volt-free)
- Occupancy Sensing - 1, 3 or 6 hour delay
- Window Activation: OFF (on display)
- 40°F (4°C) set back when window is open
- 60°F (14°C) Unoccupied temp
- Relay Rating: 16 Amps resistive or inductive
- Illumination: Seattle blue, on touch of key
- Heat Indicator: LCD, "Heater On"
- Sample Rate: 1 minute
- Delay On Or Off: 2-3 minutes
- Accuracy: ±.9°F
- Max Watts: @ 208/240V = 3320/3840
- Minimum Watts: zero
- Power Supply: 120 or 208/240 Volts
- 150 ft total loop distance

Ordering Information

MODEL	UPC	TYPE	PACKAGING	WIRE LEADS	VOLTS	AMPS	TEMP. RANGE
WR120-B	19183	Electronic Line Voltage	Single Box	3 Wire	120	16	40°F-75°F
WRP120-B	19182	Electronic Line Voltage	Single Box	3 Wire	120	16	40°F-75°F
WR230-B	19181	Electronic Line Voltage	Single Box	3 Wire	208/240	16	40°F-75°F
WRP230-B	19180	Electronic Line Voltage	Single Box	3 Wire	208/240	16	40°F-75°F

The WRP Series WINDOW WATCHER Thermostat

Residential housing projects, motels, and ski resorts often face unnecessarily high and very costly energy bills when windows and/or doors are left open for long periods of time, usually with the heating system on. Until now little could be done to curb this energy waste and expense. Introducing the WINDOW WATCHER™ thermostat, the newest addition to King's energy saving product line. This thermostat is designed to reinforce positive energy habits while limiting landlord energy expenses. With a maximum temperature of 75° the WINDOW WATCHER™ can be customized to your energy saving goals. Sensors placed in a window or door allow this smart thermostat to monitor when they are open. When the volt-free remote contacts are opened the WINDOW WATCHER™ will automatically set the thermostat back to 40°, instantly saving you money! When the window or door is closed the thermostat will automatically return to the originally set comfort temperature. An optional occupancy sensor in line allows the WINDOW WATCHER™ to set the thermostat back when a room is unoccupied, potentially saving you even more. Motels can use contacts that are key card or key activated to begin room heating when the room is occupied, keep the heat to a minimum when unoccupied. How smart and cost effective is that?! Window open set back is clearly displayed on the large back-lit LCD screen when "OFF" appears. That is when you know money is staying in your pockets, not flying carelessly out the window! With no user hold or bypass possible, the WINDOW WATCHER™ is the perfect temperature control anywhere you can not monitor but need to. The WINDOW WATCHER™: real world, confirmed energy savings. Helping to save our resources and curb less desirable energy habits.

How It Works

Small bell-type wire, 90°C (22 gauge) connected to the back of this thermostat senses if a window or door is open.

Simple magnetic switches used in alarm systems can be used as the contacts. Combined with occupancy sensors potential savings are maximized.

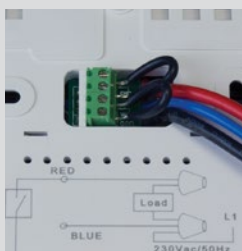

WINDOW WATCHER

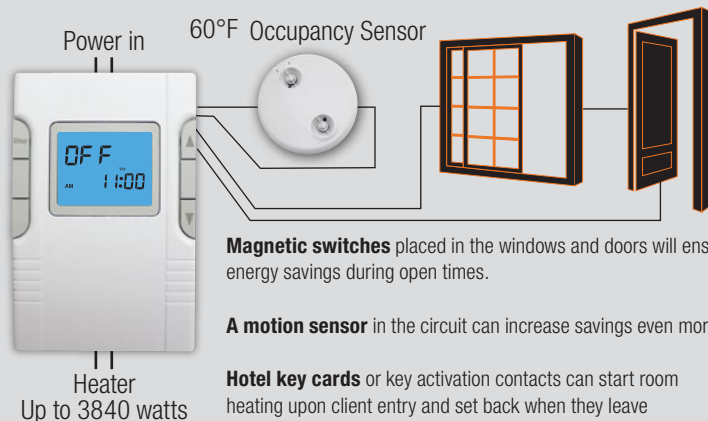

Magnetic switches placed in the windows and doors will ensure energy savings during open times.

A motion sensor in the circuit can increase savings even more.

Hotel key cards or key activation contacts can start room heating upon client entry and set back when they leave

Two Circuit Thermostat HP Series

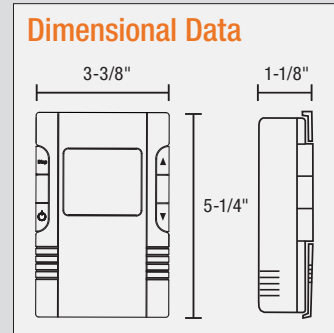

- 7 day programming
- Save Up to 28% on heating costs
- Dual single pole design with 4 wires
- Easy dial program operation
- Snap action relays
- Shallow design allows more wiring room inside full electrical boxes
- 3 minute cycle rate reduces temperature swings
- Even temperature control
- Power Failure Restart: occupant's set point
- Complies with all codes requiring anticipated or electronic thermostats
- Heat Indicator: LCD, "Heater On"
- White color with gray print
- Accuracy: $\pm 9^{\circ}\text{F}$
- Battery Powered AA

Ordering Information

MODEL	UPC	TYPE	PACKAGING	WIRE LEADS	VOLTS	AMPS	TEMP RANGE
HP30	19068	Electronic Line Voltage	Single Box	4 Wire	120/208/240	16 per pole	40°F-93°F

The HP Series Thermostat

Two Circuit Thermostat - Allows 2 independent 15 or 20 amp 2 pole circuit breakers to be controlled by one thermostat location. When a large room needs multiple heater circuits but requires one control location.

Featuring a new dial, protected from wandering fingers under the front cover, function selection is an easy twist to the left or right.

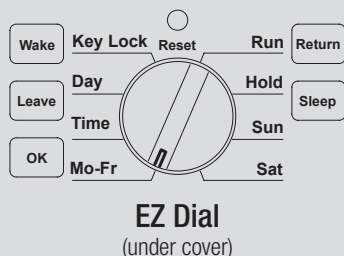

Need to quickly raise or lower the heat? Just push the up or down arrows. Tap the display button to show time, set point or current temperature. This smart thermostat will conveniently tell you by LCD icon when to change the batteries! At King we know what you want and always strive to give it to you.

2 Independent 2-Pole Breakers

OPERATION SCHEMATIC

TWO CIRCUIT
16 AMPS MAX.
PER CIRCUIT

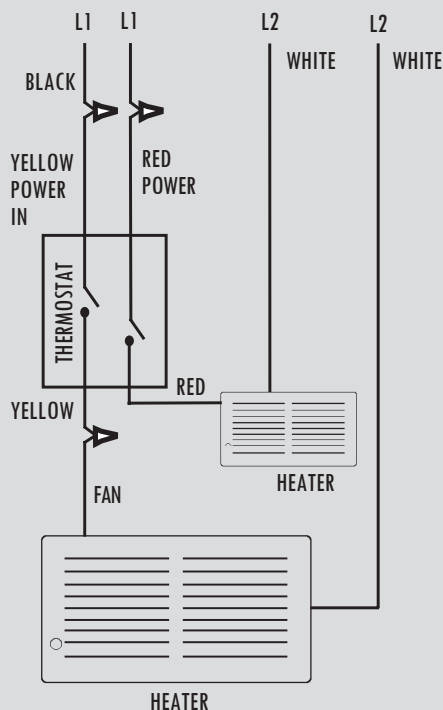

Specifications

Temperature Range: 40°F - 93°F (4°-34°C)

Temperature Default: Programs Set Point

Display Format: LCD

Display Size: Large Format

illumination: Seattle blue, on touch of key

Sample Rate: Every 60 seconds

Delay On: 1 second for relay 2

Heat Indicator: LCD "heater On"

Relay Rating: 16 Amps x (2) resistive or inductive

Relay: AA battery powered

Mounting: 2x4 electrical box

Accuracy: $\pm .9^{\circ}\text{F}$

Maximum Amps: 16 resistive or inductive

Maximum Watts per Pole:

7700 @ 240V

6656 @ 208V

3840 @ 120V

Minimum Watts: 0

Power Supply: 1 to 240 Volts AC

1 to 30 Volts DC

Installation: Leveling of the thermostat is not required. Mounting screws are provided. Mount the thermostat about five feet above the floor in an area with good air circulation. Avoid mounting the thermostat where it will be affected by drafts, air from ducts and radiant heat sources such as appliances, the sun or plumbing pipes. Typically the best location is above a light switch for that room.

Autonomous Dual Timed Stat



Timed Heating
For Building Managers
Timed Occupant Heating

- ✓ Rental Apartments
- ✓ Student Housing
- ✓ Vacation Rentals
- ✓ Air BnB
- ✓ Motels



- 2 preset setback temperatures
- 2 preset times Minor & Major
- Simple 2 button operation
- Double Pole Line Voltage
- Max room temp set point of 74°F Min 55°F
- Simple 2 button operation
- Electronic sensing for accurate temperature control ($\pm 1^\circ\text{F}$)
- For use on baseboard, fan forced & radiant electric heaters
- Manual temperature range 55° - 74°F (5° - 24°C)
- Fully vented cover allows air sensing in all directions
- Mounts directly to a single gang vertical electrical outlet box
- 1-year limited warranty

Autonomous Dual Timed Electronic Thermostat with Setback Presets

No Programming Required, Timed Comfort with tenant able to raise the temperature. Two selectable timed, minor and Major set-back temperatures, The minor setback allows for comfort up to 74 degrees for 1, 2, 3, 4, 8, 12, 16 hours before setting back to 66, 62, or 58 degrees, Major setback happens in 12, 24, 48, 36 or 60 hours and drops the temperature back to 58, 50, or 40 degrees. Simple jumper pins on the circuit board allow you to select the times and the temperatures for your application.

*Consult factory regarding options for custom time and temperature setbacks. MOQ would apply.

Ordering Information

MODEL	UPC	DESCRIPTION
K702E-DTSB		208/240V, 1P Line Voltage Electronic
Set Back Temperatures		
Minor		Major
66, 62, 58		58, 50, 40
Times: 1, 2, 3, 4, 8, 12, 16		Times: 12, 24, 36, 48, 60

Engineering Specifications

Single Pole 3 Wire
Temperature Range: 55° - 74°F (5° - 24°C) **Accuracy:** $\pm 1^\circ\text{F}$
Max Power: 3328W @ 208VAC (16A)
Max Power: 3840W @ 240VAC (16A)
Sensing Element: Electronic
 16 Amp 3850 Watts



Auto-Double Setback Stat Reduces Energy Waste

Ideal for building managers of dorms and multi-family housing motel & hotel units. Reduces energy waste by automatically setting back the room temperature. Tenant sets the desired room temperature, after a few hours the temperature automatically sets back to the Minor set point. After many hours of no temperature adjustment it sets back to the Major set point.



Line Voltage Thermostat K101, K102 & K101-C

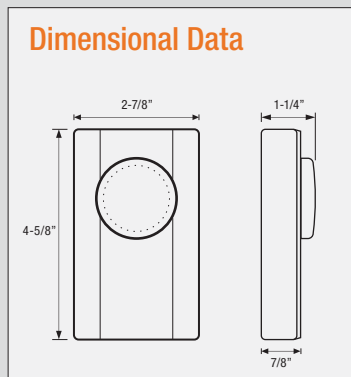

- Clean, beveled style suits any decor
- Sits flush against wall
- Includes °C and °F control dials
- Bi-metal mechanical sensing element
- Operates 41° - 90° F (3°- 32°C)
- Mounts directly to a 2x4 inch vertical electrical outlet box
- Large knob allows easy adjustment to all temperatures
- Single or Double Pole (positive off) available
- No ground wire design
- 1-year limited warranty



The K101 & K102 Series Thermostats

The K101 & K102 Series thermostats have a larger, more sensitive, mechanical bi-metal sensor that improves temperature accuracy to $\pm 3^\circ$ F. This feature achieves a better comfort level with a reduced temperature swing as compared to economy models. Modern appearance with large knob for easy adjustments. No ground wire required, making installation fast and easy.

The K101-C Cooling Thermostat

The K101-C cooling thermostat has a larger, more sensitive, bi-metal sensor that improves temperature accuracy to $\pm 3^\circ$ F. This feature achieves a better comfort level with a reduced temperature swing as compared to other mechanical thermostat models. Modern appearance with large knob for easy adjustments. No ground wire required, making installation fast and easy. For cooling only.

Ordering Information

MODEL	UPC	DESCRIPTION
K101	20576	Single Pole - WHITE
K101-R	20626	Single Pole - WHITE, RETAIL
K101A	20525	Single Pole - ALMOND
K102	20623	Double Pole (Positive Off) - WHITE
K102-R	20627	Double Pole (Positive Off) - WHITE, RETAIL
K102A	20624	Double Pole (Positive Off) - ALMOND
K101-C	20631	Single Pole - WHITE, Cooling Only

Specifications

Temperature Range: 41° F-90° F (5° C- 32° C)

Accuracy: $\pm 3^\circ$ F (1.6°C)

Max Power: 2640W@ 120VAC (22A)

Max Power: 4576W@208VAC (22A)

Max Power: 5280W@ 240VAC (22A)

Max Power: 6094W@ 277VAC (22A)

Sensing Element: Bi-metal mechanical

Line Voltage Cooling Thermostat K101-C

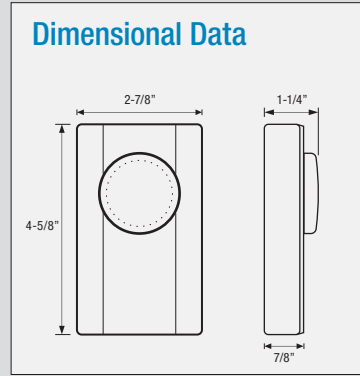

- For line voltage cooling applications
- Clean, beveled style suits any decor
- Sits flush against wall
- Includes °C and °F control dials
- Bi-metal sensing element
- Mounts directly to a 2x4 inch vertical electrical outlet box
- Fully vented cover allows air sensing in all directions
- Large knob allows easy adjustment to all temperatures
- Single Pole, Operates 41° - 90° F (3°- 32°C)
- No ground wire design

The K101-C Cooling Thermostat

The K101-C cooling thermostat has a larger, more sensitive, bi-metal sensor that improves temperature accuracy to $\pm 3^\circ$ F. This feature achieves a better comfort level with a reduced temperature swing as compared to economy models. Modern appearance with large knob for easy adjustments. No ground wire, making installation fast and easy. For cooling only.

Ordering Information

MODEL	UPC	DESCRIPTION
K101-C	20631	Single Pole - WHITE, Cooling Only

Specifications

Temperature Range: 41° F-90° F (5° C- 32° C)

Accuracy: $\pm 3^\circ$ F (1.6°C)

Max Power: 2640W@ 120VAC (22A)

Max Power: 4576W@208VAC (22A)

Max Power: 5280W@ 240VAC (22A)

Max Power: 4986W@ 277VAC (22A)

Sensing Element: Bi-metal

Certification:

Installation

Single Pole wiring
K101-C

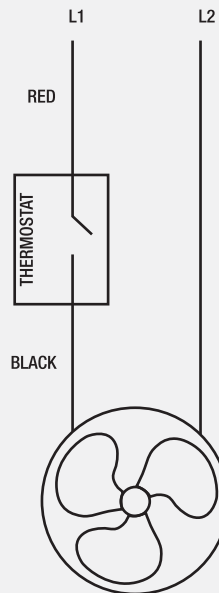

Specialty Thermostats EP3-1F56W/1F57/1E30 - N.E.M.A. 4X



EP-3 Series
Electronic Programmable Thermostat

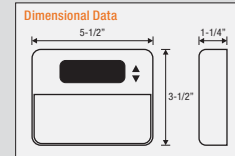

- Preprogrammed: energy saving 5-1-1 schedule, four time periods per day
- Separate baseplate to aid installation
- Battery operated: allows maximum system compatibility (two "AA" batteries included)
- Energy usage monitor: keeps track of actual operational time
- Hold mode operation: allows for manual operation. May be used for vacation setback
- Detailed wiring diagrams and instructions
- 1-year limited warranty

Ordering Information

MODEL	UPC	VOLTS	TYPE	TEMP. RANGE
EP-3	10370	24	Programmable, LCD Display - white	50°F - 90°F

Specifications

Temperature Range: 50°F to 90°F (10°C to 32°C)

Electrical Load Limit: 1.0 Amps at 24 VAC / DC

Compressor Protection Delay: 4 minutes

Temperature Display: Selectable Celsius or Fahrenheit

Time Display: Selectable 12 or 24 hour

Temperature Differential Fahrenheit:

Preset: = 3° : 2° above, 1° below set point

Selectable: 1° to 18° : +0° to 9°, -0° to 9°.

Temperature Adjustment: 1°

Display Range: 32°F to 99°F, ±2°F

Control Range: 44° to 95°F (7°C - 35°C)

Heating Unit Switch: E - Fan controlled by thermostat;

G - Fan controlled by heating unit

System Switch: 3 position (COOL - OFF - HEAT)

Fan Switch: 2 position (ON - AUTO)



1F56W/1F57/1E30 Series
Low Voltage Thermostats

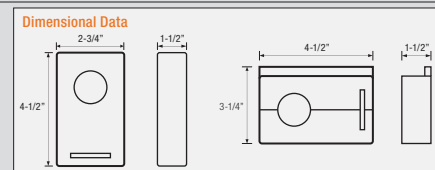

- Heating and cooling anticipators provide narrow differential control of room temperature
- Snap-on cover with clear faceplate
- Accessories available: adapter plates to allow mounting to vertical or horizontal junction boxes and to cover wall blemishes
- Removable faceplate for easy cleaning
- Beige case with gold and black dial
- 1 year warranty

Ordering Information

MODEL	UPC	VOLTS	TYPE	TEMP. RANGE
1E30-910	19000	24	Mercury Free, Vertical Mount - beige	50°F to 90°F
1F56W-444	19010	24	Mercury Free, Heat / Cool / Fan, Horizontal - white	50°F to 90°F
1F57-312	19015	24	Two Stage Heat Plus Fan Only	50°F to 90°F

Specifications

Temperature Range: 50°F to 90°F (10°C to 32°C)

Temperature Default: 55°F or 68°F (13°C or 20°C)

Display: 5° increments

Rate: 2 cycles per hour

Accuracy: ±3°F

Power Source: 24 VAC

• Three wire installation

• Snap action switch

• Flexible wire leads

• 50° to 90°F (10°C - 32°C)

• Anticipated (resistor style)

• Large bi-metal sensor

• Meets most energy codes

• For use on all types of electric heater relays; fan-forced, baseboard, radiant

with 24 Volt control circuits



TF115 NEMA 4X
Industrial Control

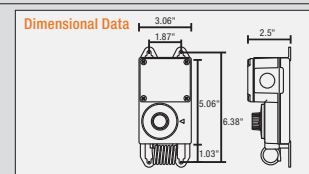

- One control for heating & cooling, makes use centralized & easy.
- Large, visible dial, making set point temperatures clear.
- UL listed & CSA certified.
- Rugged, weather resistant enclosure, enabling placement most anywhere.
- Tolerates moist conditions, performs despite water spray, high humidity, airborne contaminates & moderately corrosive conditions.
- Enclosures comply with N.E.C. Article 547, giving code compliance peace-of-mind.
- Built from corrosion resistant materials, allowing long life & reliable performance in most demanding climates.

Ordering Information

MODEL	UPC	TYPE	VOLTS	AMPS	TEMP. RANGE
TF115	19150	N.E.M.A. 4X Heating or Cooling Thermostat - Single Pole, Double Throw	120/240/277/480	25	40°F-100°F

Specifications

Amperage:

Full load -25 Amps at 120/240/277VAC;

Control: One stage heat or cool

Switch: single pole double throw

Construction: 2-piece weather resistant plastic enclosure and stainless steel exposed parts.

Ground: Leadwire

Listing: U.L., C.S.A. & N.E.M.A.

Temp: 40° - 100°F (4°C - 38°C)

• N.E.M.A. 4X enclosure complies with N.E.C. Article 547 when used with appropriate watertight connections.

• Rugged weather-resistant enclosure made of corrosion resistant materials for long life.

• One control for both heating and cooling applications

• Low mass, high surface area of stainless steel coiled sensor provides rapid response to temperature change.

• Multi-positional mounting offers flexibility in either new or existing installations.

Electronic Portable Heater PH-7

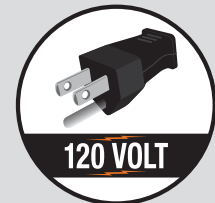

120 VOLT

NEMA 5-15P



- Energy Saving Electronic Thermostat for Accuracy
- ALCI Plug for Wet Area Protection
- 2 Heat Settings (750W/1500W)
- Ceramic Heating Element
- Large LED display
- 6 Foot Cord with 15A Plug
- Features Summer Fan Only & Timer Modes
- Power indicator light
- Internal Overheat Protection
- 1-year limited warranty

The PH-7 Electronic Portable Heater

The PH-7 Electronic portable heater is designed to provide a back-up heating source at an affordable price and includes an ALCI plug for wet area protection. By combining industry leading temperature sensing technology with a modern sleek design, the PH-7 achieves lower energy consumption with higher comfort levels by reducing temperature swings as compared to standard models with a mechanical thermostat. The convenient 6 foot cord allows greater mobility to areas needing heat. Easily set the desired temperature with the built-in electronic thermostat and the heater automatically maintains the temperature. Includes a summer fan only mode and a 1-12 hour timer. Standard color: grey body, black grill and accents. 1 year limited warranty.

Ordering Information

Dimensions

11" h x 8" w x 4 1/4" d

MODEL	UPC	VOLTS	WATTS	AMPS	LENGTH OF CORD	Plug Type
PH-7	20990	120	750/1500	6.25/12.5	6 ft.	ALCI-120V Plug

Electronic Thermostat Control For Accuracy

Control Features

- 2 Heat Setting (750/1,500W)
- Summer Fan Only Mode
- Timer Mode (1-12 hours)
- Eco Mode: 68°F Preset

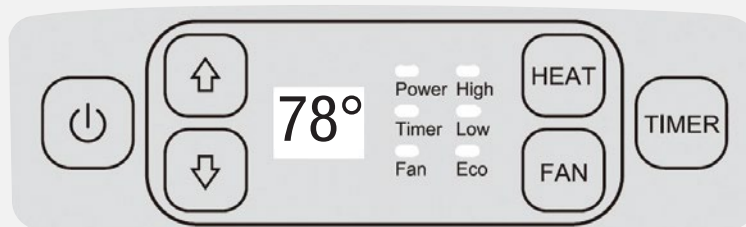

ALCI Plug
For Wet Area Protection



This heater features an ALCI (Appliance Leakage Current Interrupter) SAFETY DEVICE. This device provides protection against electric shock due to ground fault currents by automatically shutting off the power.

Can be used in wet locations such as bathrooms without worry because of the ALCI plug.

Portable Heater PH-2



Specifications

BTU..... 5120
 Watts..... 750/1500W
 Power..... 120V~60Hz
 Amps..... 12.5 A
 Heat Settings..... 2
 Cord Length..... 6 ft.

Minimum Clearance

front.....3 ft.
 top.....1 ft.
 sides.....1 ft.
 rear.....1 ft.

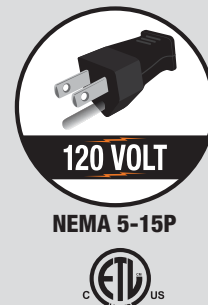

- 4 position switch, fan only/low/high/off
- Ceramic heating element
- 6 foot cord 120V plug
- Safety tip-over switch
- Adjustable thermostat
- Comfort grip handle on back
- Overheat Protection
- Power indicator light
- 1-year limited warranty

The PH-2 Portable Ceramic Fan Heater

The PH-2 portable ceramic heater with thermostat delivers comfortable warmth wherever it's needed most. This portable ceramic heater has 2 heat settings with a thermostat that helps regulate the heat automatically. The PH-2 is equipped with a Summer fan feature as well. This portable heater warms, cools and circulates air through out any room.

Ordering Information

Dimensions
 10¾"h x 7½"w x 5½"d

MODEL	UPC	VOLTS	WATTS	AMPS	Plug Type
PH-2	20986	120	750/1500	12.5	120V Plug

Portable Heater PH-16



Specifications

BTU..... 5120
 Watts..... 750/1500W
 Power..... 120V~60Hz
 Amps..... 12.5 A
 Heat Settings..... 2
 Cord Length..... 6 ft.

Minimum Clearance

front.....3 ft.
 top.....1 ft.
 sides.....1 ft.
 rear.....1 ft.

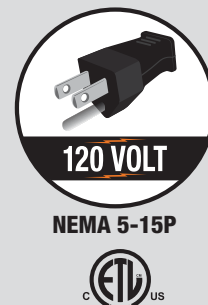

- 4 position switch, fan only/low/high/off
- Ceramic heating element
- 6 foot cord 120V plug
- Safety tip-over switch
- Adjustable thermostat
- Comfort grip handle on back
- Overheat Protection
- Power indicator light
- 1-year limited warranty

The PH-16 Portable Ceramic Fan Heater

The PH-16 portable ceramic heater with thermostat delivers comfortable warmth wherever it's needed most. This portable ceramic heater has 2 heat settings with a thermostat that helps regulate the heat automatically. The PH-16 is equipped with a Summer fan feature as well. This portable heater warms, cools and circulates air through out any room.

Ordering Information

Dimensions
 7¾"h x 71/8"w x 71/8"d

MODEL	UPC	VOLTS	WATTS	AMPS	Plug Type
PH-16	20989	120	750/1500	12.5	120V Plug

Milkhouse Heater PHM-1



Specifications

BTU..... 5120
 Watts..... 1300/1500W
 Power..... 120V~60Hz
 Amps..... 12.5 A
 Heat Settings..... 2
 Cord Length..... 6 ft.

Minimum Clearance

front.....3 ft.
 top..... 1 ft.
 sides.....1 ft.
 rear..... 1 ft.

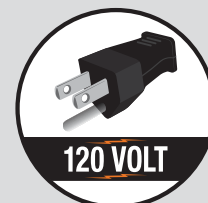

120 VOLT

NEMA 5-15P



- 4 position switch, fan only/low/high/off
- Ni-chrome heating element
- 6 foot cord 120V grounded plug
- 2 heat settings 1300/1500 watts
- Safety tip-over switch
- Adjustable thermostat
- Convenient carrying handle
- Power indicator light
- Overheat protection
- Durable powder coated steel housing
- 1-year limited warranty

The PHM-1 Portable Milkhouse Heater

The PHM-1 portable utility heater is a durable heater designed for use in garage/shop applications, where supplemental heat is needed. The PHM-1 portable utility heater is a durable heater designed for use in garage/shop applications, where supplemental heat is needed. It features a rugged and durable metal housing. The easy-to-use thermostat lets you adjust heat to the perfect level for your space. For safety, an internal switch automatically cuts off power if heater accidentally tips, falls or overheats.

Ordering Information

Dimensions

15¾" h x 9¾" w x 7½" d

MODEL	UPC	VOLTS	WATTS	AMPS	Plug Type
PHM-1	20992	120	1300/1500	12.5	120V Plug

Portable Radiant Tower Heater PHTR-9



Specifications

BTU..... 4100
 Watts..... 600/1200W
 Power..... 120V~60Hz
 Amps..... 10 A
 Heat Settings..... 2
 Cord Length..... 6 ft.

Minimum Clearance

front.....3 ft.
 top..... 1 ft.
 sides.....1 ft.
 rear..... 1 ft.

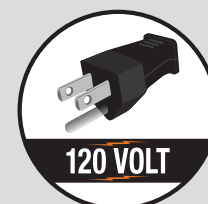

120 VOLT

NEMA 5-15P



- 2 heat settings 600/1200W
- Dual quartz radiant tower heater
- 6 foot cord 120V plug
- Safety tip-over switch
- Adjustable thermostat
- Comfort grip handle on back
- Durable powder coated steel grill stays cool to the touch
- Overheat Protection
- Power indicator light
- 1-year limited warranty

The PHTR-9 Portable Radiant Tower Heater

The PHTR-9 Dual quartz radiant tower heater has reflective heating technology that replicates the sun's healthy rays, directly warming the object or person in front of the heater. As the temperature of the heated surface rises, the warming effect is felt throughout the air and surrounding areas. Reflective heaters are great for open or large rooms, and actually save you energy by warming objects and not the entire room. Reflective heating is both safe and healthy—it produces no odors, chemicals or fumes and doesn't stir up dust. Remarkably efficient, our heater uses less power to create the same amount of heat as traditional heaters. Equipped with safety tip-over switch and overheat auto-off protection, the heater is safe and reliable.

Ordering Information

Dimensions

22¼" h x 11" w x 7½" d

MODEL	UPC	VOLTS	WATTS	AMPS	Plug Type
PHTR-9	20999	120	600/1200	5-10	120V Plug

2 Stage ECO Portable Baseboard KP1215-ECO

750/1500 Watt 2-Stage Heating

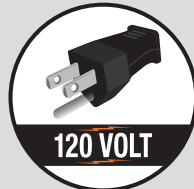

NEMA 6-15P



Model Code:

KP	12	15	-ECO
A	B	C	D

A: Series
B: 12 - 120V
C: Watts (1500)
D: Energy Saving ECO-stat



- Dual wattage 750/1500W element
- 2-Stage, Energy saving ECO-stat
- ECO-indicating lights
- High temperature limit
- Lighted ON/OFF power switch
- 6 foot cord with grounded plug
- All angle tip-over switch
- White finish/Gray trim
- Quiet and efficient convection heat
- Convenient carry handle on back
- With rounded corners and wide base feet
- 1-year limited warranty



The KP1215-ECO Portable Baseboard Heater

King Electric's KP1215-ECO with EcoStat automatically uses the lowest wattage required to heat the room, reducing energy consumption. The EcoStat ensures consistent comfort by minimizing room temperature swings. In a cold room it utilizes full power to heat a room quickly. Once the desired temperature is achieved, the heater automatically reduces the wattage to maintain the room temperature. Maximum comfort is achieved.

Ordering Information

MODEL	UPC	VOLTS	WATTS	LENGTH	BTUH	AMPS	PLUG TYPE	WEIGHT (lbs.)
KP1215-ECO	20794	120	750/1500	5 FT.	2560/5120	6.25-12.5	120V Plug	11.5

KP1215-ECO

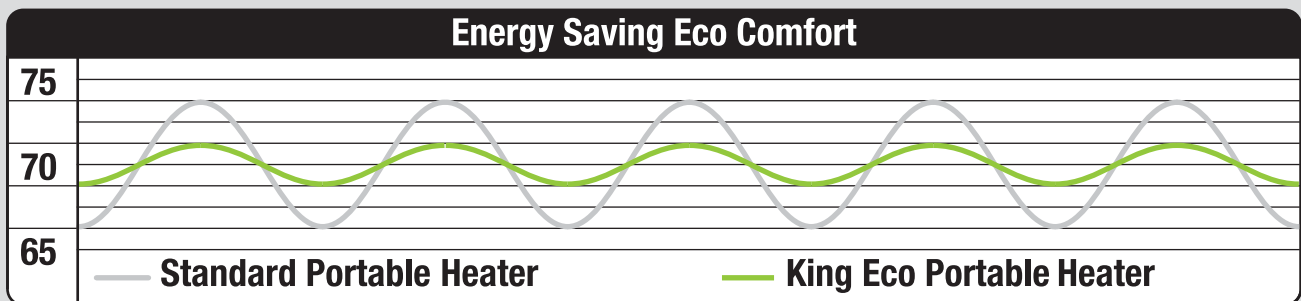

Dimensional Data

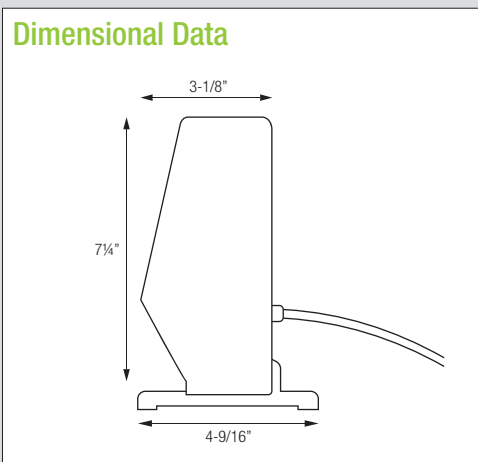

Crush Proof Design - dual wattage element

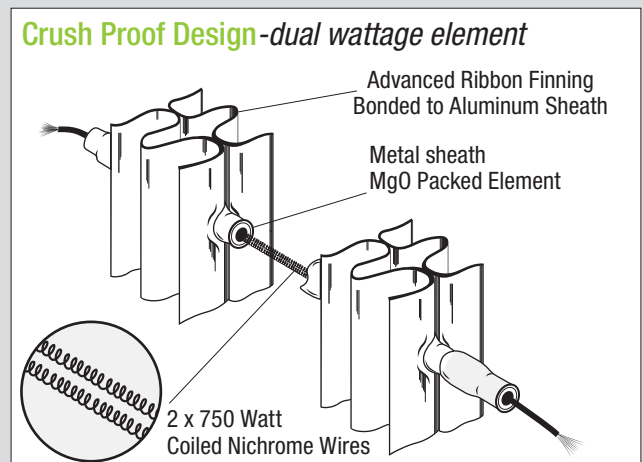

Portable Baseboard KP/KPH Series



Model Code:

KP	12	10
A	B	C

A: Series
B: Volts 120V
C: Watts 1000



- Aluminum finned element
- Convection heat
- All angle tip-over switch
- 6 ft. cord w/ grounded plug, 120V
- Baked enamel finish
- Molded base feet
- Carrying handle on back
- Standard Color: white
- Full length safety cutout
- Quiet running
- Pilot light
- Built in thermostat
- 1-year limited warranty

The KP/KPH Series Portable Baseboard Heater

A portable baseboard is an easy way to add supplementary heat to any room. Baseboards are quiet and trouble-free. A tip-over switch is standard so if the heater is knocked over it will automatically shut off. A built-in thermostat and a 6 foot, 3-wire grounded outlet plug for additional safety are provided. This heater is so rugged it is approved for U.S. government contracts.

Ordering Information

MODEL	UPC	VOLTS	WATTS	AMPS	LENGTH	SHIP WEIGHT lbs
KP1210	10142	120	1000	8.3	4 ft.	11.5
KPH1210	10143	120	1000	8.3	3 ft.	9.0

Engineering Specifications

Approvals: UL (E29778)

Plug Configurations

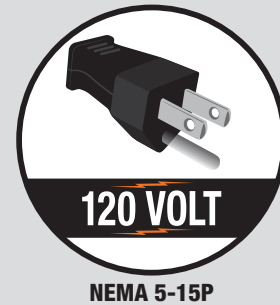

Dimensional Data

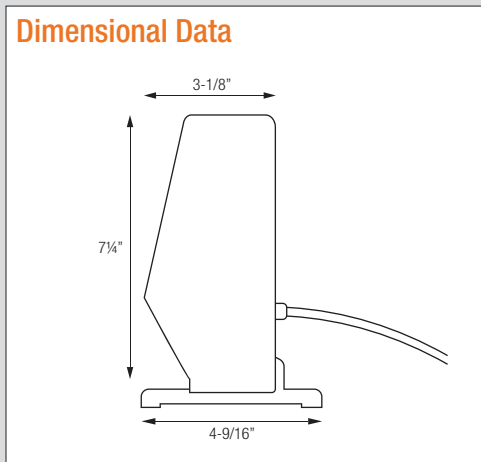

Crush Proof Design

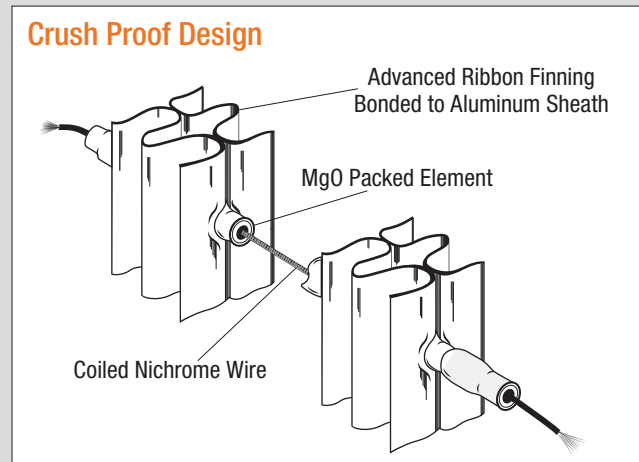

Portable Utility Heater PUH Series



Model Code:

PUH	12	15	T
A	B	C	D
A: Series			
B: 12 - 120V			
C: Watts (1500)			
D: T - Thermostat			



- Built-in thermostat (45°-85°F)
- Dual On/off rocker switches (750W ea.)
- 6 foot cord with 15A plug
- 120V (750W/1500W)
- Rugged metal case
- Comfort grip handle
- Ceramic heating elements
- Power indicator light
- Permanently lubricated motor ensures long life
- Durable scratch and rust resistant finish
- 1-year limited warranty

The PUH1215T Portable Utility Heater

The PUH1215T personal utility heater is designed to provide a back-up heating source at an affordable price.

The convenient 6 foot cord allows greater mobility to areas needing heat. Easily set the desired temperature with the built-in thermostat. The auto-reset high-limit temperature control provides overheat protection. Standard color: grey body, black grill and handle. 1 year limited warranty.

Ordering Information

Dimensions

7½"h x 6½"w x 5"d

MODEL	UPC	VOLTS	WATTS	AMPS	Plug Type
PUH1215T	20982	120	750/1500	12.5	120V Plug



Specifications

BTU.....	5100B
Watts.....	750W / 1500W
Power (Volts).....	120V~60Hz
Amps.....	12.5 A
Cord Length.....	6 ft.
Switch.....	(2) 750/1500 ON/OFF
Air Flow.....	216 CFM Fan

Minimum Clearance

front.....	3 ft.
top.....	1 ft.
sides.....	1 ft.
rear.....	1 ft.

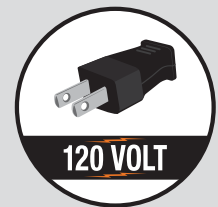

NEMA 1-15P

Portable Shop Heater PSH1215T



Model Code:

PSH	12	15	T
A	B	C	D

A: Series
 B: 12 - 120V
 C: Watts (1500)
 D: T - Thermostat

Yellow Jacket Mini™



- Built-in thermostat
- On/off switch
- Adjustable tilt control
- Spiral finned heating element
- 6 Foot Cord with 15 Amp plug
- Comfort grip handle
- Auto-reset safety limit
- Power indicator light
- Permanently lubricated motor
- Durable scratch and rust resistant finish
- 1-year limited warranty

The PSH1215T Portable Shop Heater

The PSH1215T is a rugged portable heater designed to provide supplemental heat at an affordable price. Perfectly suited for personal use applications and small workshops/worksites. The convenient 6 foot cord allows greater mobility to areas needing heat. Easily set the desired temperature with the built-in thermostat. Sure stop high-limit temperature control provides overheat protection. Standard color: yellow body, black grill and handle. 1 year warranty.

Ordering Information

MODEL	UPC	VOLTS	WATTS	AMPS	Plug Type
PSH1215T	20634	120	1500	12.5	120V Plug



Specifications

BTU..... 5100B
 Watts..... 1500W
 Power (Volts)..... 120V~60Hz
 Amps..... 12.5 A
 Cord Length..... 6 ft.
 Switch..... ON / OFF
 Air Flow..... 216 CFM

Minimum Clearance

front..... 3 ft.
 top..... 1 ft.
 sides..... 1 ft.
 rear..... 1 ft.

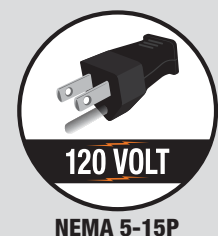

Portable Shop Heater PSH2440TB



Model Code:

PSH	24	40	T	B
A	B	C	D	E

A: Series
B: 24 - 240V
C: Watts (4000)
D: T - Thermostat
E: B - Bracket

Yellow Jacket Junior™



- Standard color: Yellow with black accents
- Includes both comfort grip & storage handle
- High limit temperature control with manual reset
- 300 CFM fan
- Stainless steel tubular heating element
- Built-in thermostat (45-85°F)
- Standard finish epoxy/polyester paint
- Handle may be used as a reel for the electric cable
- Mounting bracket for wall or ceiling installation included
- Power indicating light
- 3 pronged 20A 250 VAC outlet required
- 6 ft. (2m) cord NEMA 6-20P
- 51° F temperature rise
- Auto fan delay
- 1-year limited warranty

The PSH Portable Shop Heater

The PSH is a high power portable heater designed to provide a back-up heating source at an affordable price. Perfectly suited for the workshop, garage or construction sites. The convenient 6 foot cord allows greater mobility to areas needing heating, while the handle serves as a reel for the cord when not in use. Easily set the desired temperature with the built-in thermostat. Sure stop high-limit temperature control with manual reset provides overheat protection. With a 300 CFM fan, heat is dispersed efficiently. Standard color: Yellow. 240 Volt Single Phase. 1-year warranty.

Ordering Information

MODEL	UPC	VOLTS	WATTS	AMPS	Plug Type
PSH2440TB	20637	240/208*	4,000/3,000	16/14	NEMA #6-20P

*Dual rated heaters will draw 13% less amps and 25% less wattage when operated at 208V.

Easy Installation

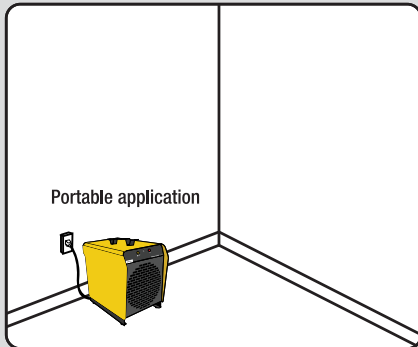

Place on the floor and plug into 20 Amp outlet

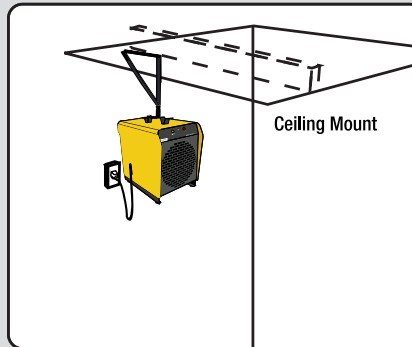

Mount bracket to ceiling joist and attach heater

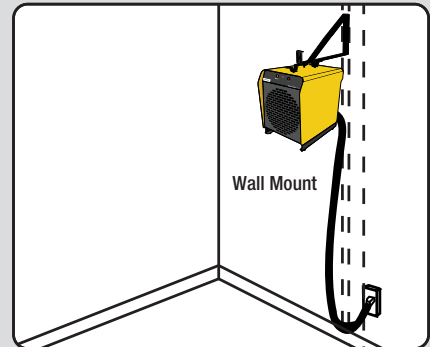

Mount bracket to wall stud and attach heater

Specifications

BTU.....	13,000B
Watts.....	3,750W
Heating Area (ft²).....	450 ft²
Power (Volts).....	240V~60Hz
Amps.....	16 A
Heat Settings 1.....	On/Off
Heat Settings 2.....	Thermostat

Minimum Clearance

front.....	3 ft.
top.....	1 ft.
sides.....	1 ft.
rear.....	1 ft.

Receptacle Type:

**20A-240V
NEMA #6-20R**
(NOT INCLUDED)

Ground

NOT 120 VOLT

**240 VOLT
Receptacle
Required**

*WILL NOT operate on 120V household receptacles

*See label on front panel for specific receptacle type

Portable Garage Heater PGH Series



Receptacle Type:
30A-250V
NEMA #6-30R
Ground (NOT INCLUDED)

NOT 120 VOLT
WILL NOT operate on 120V household receptacles

240 VOLT
Receptacle Required
*See label on front panel for specific receptacle type

Model Code:

PGH	24	48	-ETB
A	B	C	D

A: Series
B: 24 - 240V
C: Watts (4800)
D: ETB - Electronic
Thermostat & Bracket



- ECO2S controller
- Energy efficient 2-stage heating
- Fan only mode
- Timer mode (1-9 Hours)
- Remote control with wall-mount holder included
- Large LED display
- SureStop™ Limit Protection
- Stainless steel tube elements
- 6 foot cord
- Carrying handle with built-in cord storage
- Universal wall/ceiling bracket included
- Limited 1-year warranty

The ECO2S 2-Stage Portable Garage Heater with IR Remote Control

The ECO2S PGH Series portable garage heater offers unparalleled performance, energy efficiency and user control by incorporating another King innovation, the in-built ECO2S electronic thermostat with remote control. Offering energy efficient 2-stage heating, with ECO mode that automatically uses the lowest wattage needed to heat the room, integrated fan only and timer modes, as well as a remote control for simple operation. The included universal wall / ceiling bracket and convenient 6 foot cord, allows for greater mobility to areas needing heat. The SureStop™ high-temperature limit, with auto-rest provides protection from overheating.

Ordering Information

MODEL	UPC	VOLTS	WATTS	AMPS	Plug Type
PGH2448-ETB	20980	240/208*	4800/3600	20/17	30A-250V NEMA 6-30P

*Dual rated heaters will draw 13% less amps and 25% less wattage when operated at 208V.

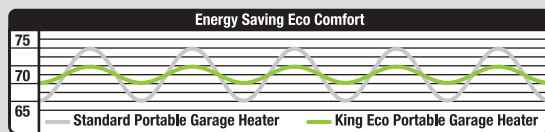

*4800W

Receptacle Type:
30A-250V
NEMA #6-30R
Ground (NOT INCLUDED)

**4000W

Receptacle Type:
20A-240V
NEMA #6-20R
Ground (NOT INCLUDED)

NOT 120 VOLT
WILL NOT operate on 120V household receptacles

240 VOLT
Receptacle Required
*See label on front panel for specific receptacle type

Model Code:

PGH	24	48	T	B
A	B	C	D	E

A: Series
B: 24 - 240V
C: Watts (4000) (4800)
D: T - Thermostat
E: B - Bracket



- In-built thermostat and On/Off Switch
- SureStop™ Limit Protection
- Auto-reset Fan Delay increases efficiency
- Stainless Steel tube elements
- 6 foot cord
- Carrying handle with built-in cord storage
- Universal wall / ceiling bracket included
- Durable scratch and rust resistant finish
- Limited 1-year warranty

The PGH Series Portable Garage Heater

The PGH Series is a rugged portable heater designed to provide a high capacity heating source at an affordable price. Perfectly suited for workshops, garages or construction sites. Easily set the desired temperature with the in-built mechanical thermostat. Offering a SureStop™ high temperature-limit, with auto-reset providing protection from overheating.

Ordering Information

MODEL	UPC	VOLTS	WATTS	AMPS	Plug Type
PGH2448TB*	20984	240/208	4800/3600	20/17	30A-250V NEMA 6-30P+
PGH2440TB*	20998	240/208	4000/3000	16/14	20A -240V NEMA 6-20P++

*Does not come with electronic control or remote

Radiant Heater RSH1215



Model Code:

RSH	12	15
A	B	C

A: Series
B: 12 - 120V
C: Watts (1500)

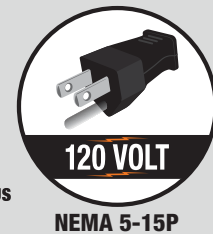

- 1500W Infrared quartz heating tube
- For dry locations only
- 6 foot cord 120V grounded plug
- Anti-freeze function
- Adjustable thermostat
- Overheat Protection
- Durable extruded aluminum housing
- Wall or ceiling mount bracket included
- 1-year limited warranty

The RSH1215 Infrared Quartz Heater

The RSH1215 1500W Infrared quartz heater has the ability to transfer heat to a person or object without heating the surrounding air. The RSH1215 is commonly used for indoor or outdoor covered spaces spot heating. Perfect for garages, covered patios, or workshops. The universal wall and ceiling mounting bracket is easy to install and angle is adjustable to suit your needs.

Ordering Information

Dimensions
7½" h x 34½" w x 3¾" d

MODEL	UPC	VOLTS	WATTS	AMPS	Plug Type
RSH1215	20983	120	1500	12.5	120V Plug

Accessories

MODEL	UPC	DESCRIPTION	WEIGHT
RLAMP1215	20981	REPLACEMENT LAMPS	1

Specifications

Watts.....	1500W
Power (Volts).....	120V~60Hz
Amps.....	12.5 A
Cord Length.....	6 ft.
Heat Settings.....	1
Approvals.....	

Easy Installation

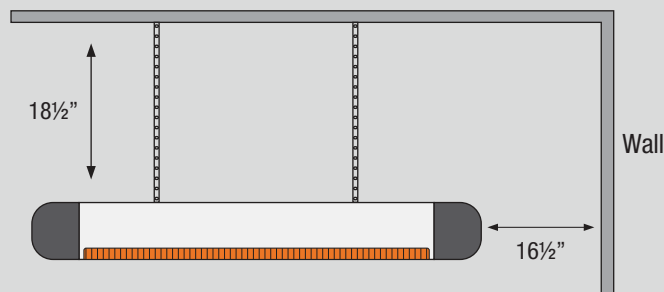
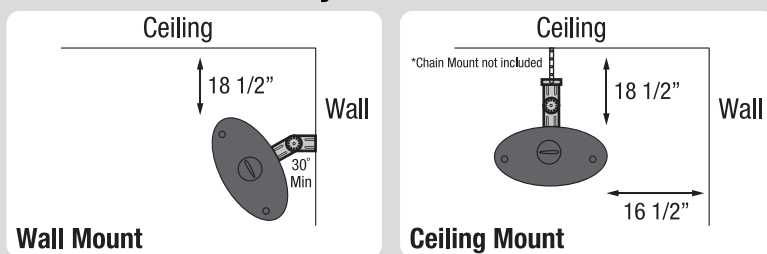

Locate stud in ceiling or wall and securely fasten bracket. Attach heater to bracket, adjust to desired position and tighten down. Must have minimum 72" clearance from the floor.

Commercial Radiant Heater RH Series



Model Code:

RH 33 B 1 B 25W
A B C D E F

- A: Series
- B: Length
- C: Housing Color
B-Black, S-Stainless
- D: Lamp Quantity
- E: Volts A=120, B=208
C=240, D=480, E=575
- F: Wattage



- Black powder-coat aluminized steel housing
- Optional stainless steel housing
- 0° to 45° adjustable brackets included
- Gold colored anodized aluminum reflectors
- Wide, symmetrical design
- Coiled tungsten filament in sealed quartz tube
- Porcelain end caps
- Instantaneous heat-up & cool-down
- Clear or optional glare reducing ruby quartz
- ETL Listed for indoor & outdoor applications
- Commercial/Industrial Approval
- Tested to CSA 22.2 #46 - M1988, UL 2021, 1997

The RH Radiant Heater Series

RH Series radiant heaters have the ability to transfer heat to a person or object without heating the surrounding air. Commonly used for indoor and outdoor application such as restaurant patios, parking garages, work stations, valet waiting areas, vestibules and airport/hospital entrances. RH series heaters are ideal for any application requiring total or supplemental (spot) heating in commercial and industrial areas.

Models In Stock

LAMP COLOR	LAMP TYPE	BLACK (POWDER COAT)	UPC	VOLTS	WATTS	BTUH	AMPS	LAMP PART#	WT. (lbs.)
CLEAR (WHITE)	SINGLE LAMP	RH-33B1-B25W	32411	208	2,500	8,530	12.02	EL-072A	19
CLEAR (WHITE)	SINGLE LAMP	RH-33B1-C25W	32412	240	2,500	8,530	10.42	EL-074A	19
CLEAR (WHITE)	DOUBLE LAMP	RH-24B2-B16W	32425	208	3,200	10,919	15.38	EL-071A	20
CLEAR (WHITE)	DOUBLE LAMP	RH-24B2-C16W	32426	240	3,200	10,919	13.33	EL-073A	20
CLEAR (WHITE)	DOUBLE LAMP	RH-33B2-B25W	32428	208	5,000	17,061	24.04	EL-072A	26
CLEAR (WHITE)	DOUBLE LAMP	RH-33B2-C25W	32429	240	5,000	17,061	20.83	EL-074A	26
CLEAR (WHITE)	TRIPLE LAMP	RH-33B3-G25W †	32444	480	7,500	24,909	15.63	EL-076A	32

Models Available for Special Order Single Lamp Models

LAMP COLOR	BLACK (POWDER COAT)	UPC	STAINLESS STEEL	UPC	VOLTS	WATTS	BTUH	AMPS	LAMP PART#	WT. (lbs.)
CLEAR (WHITE)	RH-24B1-A16W	32407	RH-24S1-A16W	32453	120	1,600	5,459	13.3	EL-070A	15
CLEAR (WHITE)	RH-24B1-B16W	32408	RH-24S1-B16W	32454	208	1,600	5,459	7.69	EL-071A	15
CLEAR (WHITE)	RH-24B1-C16W	32409	RH-24S1-C16W	32455	240	1,600	5,459	6.67	EL-073A	15
CLEAR (WHITE)	RH-24B1-G16W	32410	RH-24S1-G16W	32456	480	1,600	5,459	3.33	EL-075A	15
CLEAR (WHITE)	RH-33B1-B25W	32411	RH-33S1-B25W	32457	208	2,500	8,530	12.02	EL-072A	19
CLEAR (WHITE)	RH-33B1-C25W	32412	RH-33S1-C25W	32458	240	2,500	8,530	10.42	EL-074A	19
CLEAR (WHITE)	RH-33B1-G25W	32413	RH-33S1-G25W	32459	480	2,500	8,530	5.21	EL-076A	19
CLEAR (WHITE)	RH-46B1-G36W †	32414	RH-46S1-G36W †	32460	480	3,650	12,454	7.6	EL-077A	24
CLEAR (WHITE)	RH-46B1-H38W †	32415	RH-46S1-H38W †	32461	575	3,800	12,966	6.61	EL-078A	24
REDUCED GLARE (RUBY)	RH-24B1-A16R	32416	RH-24S1-A16R	32462	120	1,600	5,459	13.3	EL-080A	15
REDUCED GLARE (RUBY)	RH-24B1-B16R	32417	RH-24S1-B16R	32463	208	1,600	5,459	7.69	EL-081A	15
REDUCED GLARE (RUBY)	RH-24B1-C16R	32418	RH-24S1-C16R	32464	240	1,600	5,459	6.67	EL-083A	15
REDUCED GLARE (RUBY)	RH-24B1-G16R	32419	RH-24S1-G16R	32465	480	1,600	5,459	3.33	EL-085A	15
REDUCED GLARE (RUBY)	RH-33B1-B25R	32420	RH-33S1-B25R	32466	208	2,500	8,530	12.02	EL-082A	19
REDUCED GLARE (RUBY)	RH-33B1-C25R	32421	RH-33S1-C25R	32467	240	2,500	8,530	10.42	EL-084A	19
REDUCED GLARE (RUBY)	RH-33B1-G25R	32422	RH-33S1-G25R	32468	480	2,500	8,530	5.21	EL-086A	19
REDUCED GLARE (RUBY)	RH-46B1-G36R †	32423	RH-46S1-G36R †	32469	480	3,650	12,454	7.6	EL-087A	24
REDUCED GLARE (RUBY)	RH-46B1-H38R †	32424	RH-46S1-H38R †	32470	575	3,800	12,966	6.61	EL-088A	24

† Not Available to Ship UPS, Truck Line Only.

Commercial Radiant Heater RH Series

Dual Lamp Models

LAMP COLOR	BLACK (POWDER COAT)	UPC	STAINLESS STEEL	UPC	VOLTS	WATTS	BTUH	AMPS	LAMP PART#	WT. (lbs.)
CLEAR (WHITE)	RH-24B2-B16W	32425	RH-24S2-B16W	32471	208	3,200	10,919	15.38	EL-071A	20
CLEAR (WHITE)	RH-24B2-C16W	32426	RH-24S2-C16W	32472	240	3,200	10,919	13.33	EL-073A	20
CLEAR (WHITE)	RH-24B2-G16W	32427	RH-24S2-G16W	32473	480	3,200	10,919	6.67	EL-075A	20
CLEAR (WHITE)	RH-33B2-B25W	32428	RH-33S2-B25W	32474	208	5,000	17,061	24.04	EL-072A	26
CLEAR (WHITE)	RH-33B2-C25W	32429	RH-33S2-C25W	32475	240	5,000	17,061	20.83	EL-074A	26
CLEAR (WHITE)	RH-33B2-G25W	32430	RH-33S2-G25W	32476	480	5,000	17,061	10.42	EL-076A	26
CLEAR (WHITE)	RH-46B2-G36W †	32431	RH-46S2-G36W †	32477	480	7,300	24,909	15.21	EL-077A	32
CLEAR (WHITE)	RH-46B2-H38W †	32432	RH-46S2-H38W †	32478	575	7,600	25,932	13.22	EL-078A	32
REDUCED GLARE (RUBY)	RH-24B2-B16R	32433	RH-24S2-B16R	32479	208	3,200	10,919	15.38	EL-081A	20
REDUCED GLARE (RUBY)	RH-24B2-C16R	32434	RH-24S2-C16R	32480	240	3,200	10,919	13.33	EL-083A	20
REDUCED GLARE (RUBY)	RH-24B2-G16R	32435	RH-24S2-G16R	32481	480	3,200	10,919	6.67	EL-085A	20
REDUCED GLARE (RUBY)	RH-33B2-B25R	32436	RH-33S2-B25R	32482	208	5,000	17,061	24.04	EL-082A	26
REDUCED GLARE (RUBY)	RH-33B2-C25R	32437	RH-33S2-C25R	32483	240	5,000	17,061	20.83	EL-084A	26
REDUCED GLARE (RUBY)	RH-33B2-G25R	32438	RH-33S2-G25R	32484	480	5,000	17,061	10.42	EL-086A	26
REDUCED GLARE (RUBY)	RH-46B2-G36R †	32439	RH-46S2-G36R †	32485	480	7,300	24,909	15.21	EL-087A	32
REDUCED GLARE (RUBY)	RH-46B2-H38R †	32440	RH-46S2-H38R †	32486	575	7,600	25,932	13.22	EL-088A	32

Triple Lamp Models

LAMP COLOR	BLACK (POWDER COAT)	UPC	STAINLESS STEEL	UPC	VOLTS	WATTS	BTUH	AMPS	LAMP PART#	WT. (lbs.)
CLEAR (WHITE)	RH-24B3-B16W	32441	RH-24S3-B16W	32487	208	4,800	16,378	23.08	EL-071A	25
CLEAR (WHITE)	RH-24B3-C16W	32442	RH-24S3-C16W	32488	240	4,800	16,378	20	EL-073A	25
CLEAR (WHITE)	RH-24B3-G16W	32443	RH-24S3-G16W	32489	480	4,800	16,378	10	EL-075A	25
CLEAR (WHITE)	RH-33B3-G25W †	32444	RH-33S3-G25W †	32490	480	7,500	24,909	15.63	EL-076A	32
CLEAR (WHITE)	RH-46B3-G36W †	32445	RH-46S3-G36W †	32491	480	10,950	37,636	22.81	EL-077A	40
CLEAR (WHITE)	RH-46B3-H38W †	32446	RH-46S3-H38W †	32492	575	11,400	38,898	19.83	EL-078A	40
REDUCED GLARE (RUBY)	RH-24B3-B16R	32447	RH-24S3-B16R	32493	208	4,800	16,378	23.08	EL-081A	25
REDUCED GLARE (RUBY)	RH-24B3-C16R	32448	RH-24S3-C16R	32494	240	4,800	16,378	20	EL-083A	25
REDUCED GLARE (RUBY)	RH-24B3-G16R	32449	RH-24S3-G16R	32495	480	4,800	16,378	10	EL-085A	25
REDUCED GLARE (RUBY)	RH-33B3-G25R †	32450	RH-33S3-G25R †	32496	480	7,500	24,909	15.63	EL-086A	32
REDUCED GLARE (RUBY)	RH-46B3-G36R †	32451	RH-46S3-G36R †	32497	480	10,950	37,636	22.81	EL-087A	40
REDUCED GLARE (RUBY)	RH-46B3-H38R †	32452	RH-46S3-H38R †	32498	575	11,400	38,898	19.83	EL-088A	40

Dimensional Data

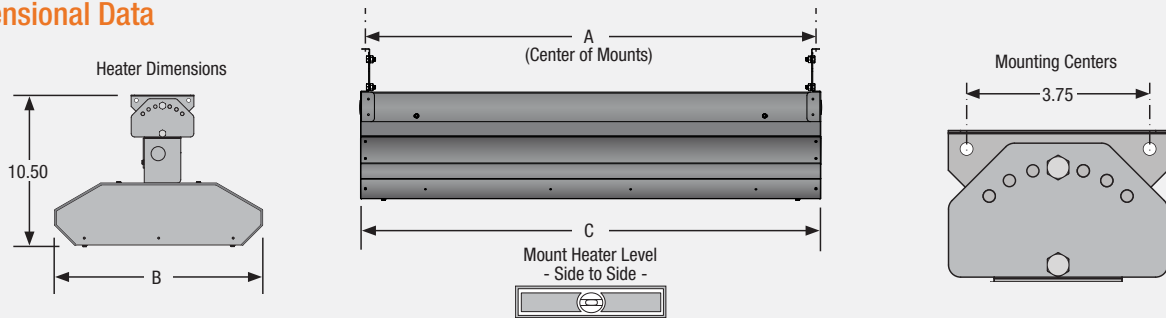

Physical Dimensions

MODEL	A	B	C
RH-24-X1	23½"	9¼"	24"
RH-24-X2	23½"	15"	24"
RH-24-X3	23½"	20¾"	24"
RH-33-X1	32½"	9¼"	33"
RH-33-X2	32½"	15"	33"
RH-33-X3	32½"	20¾"	33"
RH-46-X1	45½"	9¼"	46"
RH-46-X2	45½"	15"	46"
RH-46-X3	45½"	20¾"	46"

† Not Available to Ship UPS, Truck Line Only.

Commercial Radiant Heater RH Series

RH Series Basic Heating Application Chart

SERIES	LAMP QTY.	RECOMMEND MOUNTING HEIGHT (Dim A)	RECOMMENDED DISTANCE BETWEEN HEATERS (Dim B)	APPROX. SQ. FT. COVERAGE	APPROX. WATTS PER SQ. FT.
RH-24	1	7 to 9 FT.	2 to 7 FT.	200	4
RH-24	2	7 to 9 FT.	3 to 9 FT.	200	8
RH-24	3	8 to 10 FT.	4 to 11 FT.	300	8
RH-33	1	7 to 9 FT.	3 to 9 FT.	200	6
RH-33	2	8 to 10 FT.	4 to 11 FT.	300	8
RH-33	3	8 to 10 FT.	5 to 13 FT.	300	11
RH-46	1	8 to 10 FT.	4 to 11 FT.	300	7 to 10
RH-46	2	10 to 14 FT.	5 to 13 FT.	500	8 to 12
RH-46	3	10 to 15 FT.	6 to 15 FT.	500	12 to 18

*Clearance to combustibles published in the RH Series Installation, Operation, Maintenance and Parts Manuals and on safety labels must be maintained at all times. Factory recommended mounting heights are listed as a guideline. If infrared heaters are mounted too low or too high, they may result in discomfort or lack of heat.

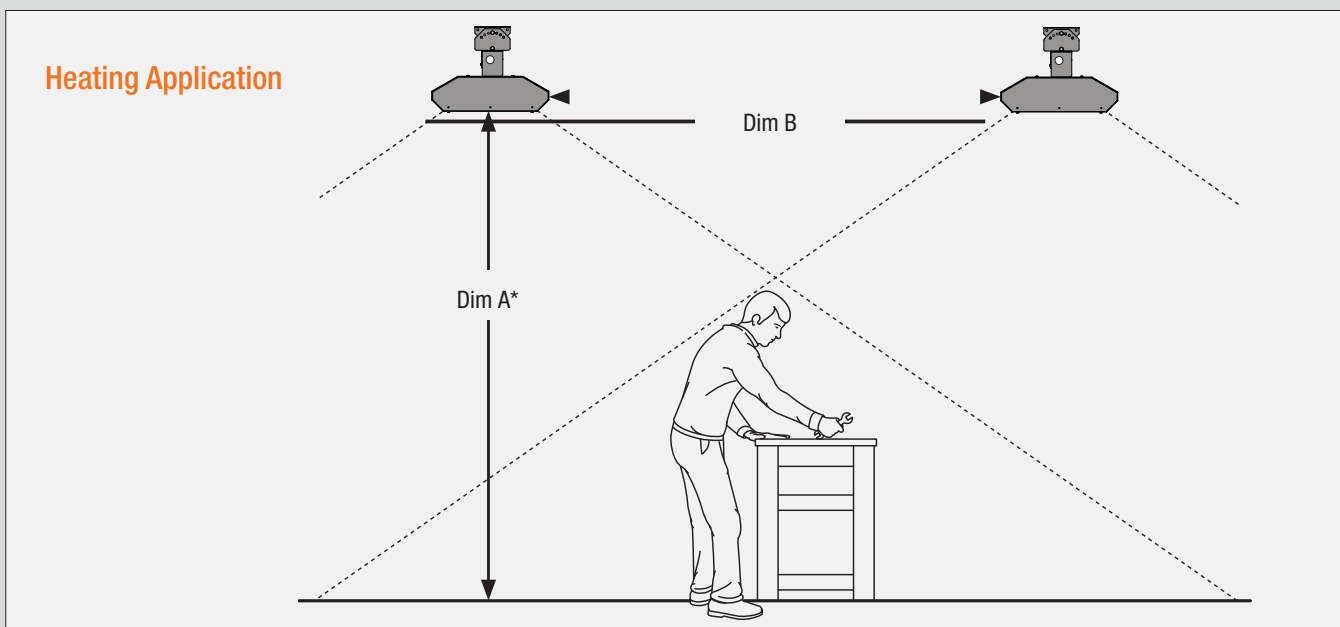

Replacement Lamp Elements

MODEL	UPC	VOLTS	WATTS	FOR USE WITH	LAMP LENGTH	LAMP COLOR	WEIGHT
EL-070A	32610	120	1,600	A16W	21" (533 mm)	CLEAR (WHITE)	2 lbs (0.9 kg)
EL-071A	32611	208	1,600	B16W	20" (533 mm)	CLEAR (WHITE)	2 lbs (0.9 kg)
EL-072A	32612	208	2,500	B25W	30" (762 mm)	CLEAR (WHITE)	3 lbs (1.4 kg)
EL-073A	32613	240	1,600	C16W	21" (533 mm)	CLEAR (WHITE)	2 lbs (0.9 kg)
EL-074A	32614	240	2,500	C25W	30" (762 mm)	CLEAR (WHITE)	3 lbs (1.4 kg)
EL-075A	32615	480	1,600	G16W	21" (533 mm)	CLEAR (WHITE)	2 lbs (0.9 kg)
EL-076A	32616	480	2,500	G25W	30" (762 mm)	CLEAR (WHITE)	3 lbs (1.4 kg)
EL-077A	32617	480	3,650	G36W	43" (1092 mm)	CLEAR (WHITE)	4 lbs (1.8 kg)
EL-078A	32618	575	3,800	H38W	43" (1092 mm)	CLEAR (WHITE)	4 lbs (1.8 kg)
EL-080A	19231	120	1,600	A16R	21" (533 mm)	REDUCED GLARE (RUBY)	2 lbs (0.9 kg)
EL-081A	19232	208	1,600	B16R	21" (533 mm)	REDUCED GLARE (RUBY)	2 lbs (0.9 kg)
EL-082A	19233	208	2,500	B16R	30" (762 mm)	REDUCED GLARE (RUBY)	3 lbs (1.4 kg)
EL-083A	19234	240	1,600	C16R	21" (533 mm)	REDUCED GLARE (RUBY)	2 lbs (0.9 kg)
EL-084A	19235	240	2,500	C25R	30" (762 mm)	REDUCED GLARE (RUBY)	3 lbs (1.4 kg)
EL-085A	19236	480	1,600	G16R	21" (533 mm)	REDUCED GLARE (RUBY)	2 lbs (0.9 kg)
EL-086A	19237	480	2,500	G25R	30" (762 mm)	REDUCED GLARE (RUBY)	3 lbs (1.4 kg)
EL-087A	19238	480	3,650	G36R	43" (1092 mm)	REDUCED GLARE (RUBY)	4 lbs (1.8 kg)
EL-0868A	19239	575	3,800	H38R	43" (1092 mm)	REDUCED GLARE (RUBY)	4 lbs (1.8 kg)

Commercial Radiant Heater RH Series

Clearance to Combustibles in Inches

Model Wattage	Mounting Angle	Side				
		Front	Behind*	End	Top	Below
1,600	0°	24	24	24	6	40
	45°	40	24	24	10	40
2,500	0°	24	24	24	6	46
	45°	46	24	24	10	46
3,200	0°	24	24	24	6	56
	45°	56	24	24	10	56
3,650 3,800	0°	24	24	24	6	62
	45°	62	24	24	10	62
4,800	0°	24	24	24	6	72
	45°	72	24	24	10	72
5,000	0°	24	24	24	6	72
	45°	72	24	24	10	72
7,300	0°	24	24	24	6	84
	45°	84	24	24	10	84
7,500 7,600	0°	24	24	24	6	84
	45°	84	24	24	10	84
10,950 11,400	0°	24	24	24	6	96
	45°	96	24	24	10	96

*A minimum clearance of 36 inches must be maintained from behind another heater

NOTE: Ensure that building materials with a low heat tolerance (i.e., awnings, fabrics, plastics, sprinklers, insulation, etc.) are protected against degradation. This may require the heater to be mounted at a distance in excess of the published clearances to combustibles. Contact the material manufacturer for specific details.

Clearance to Combustibles

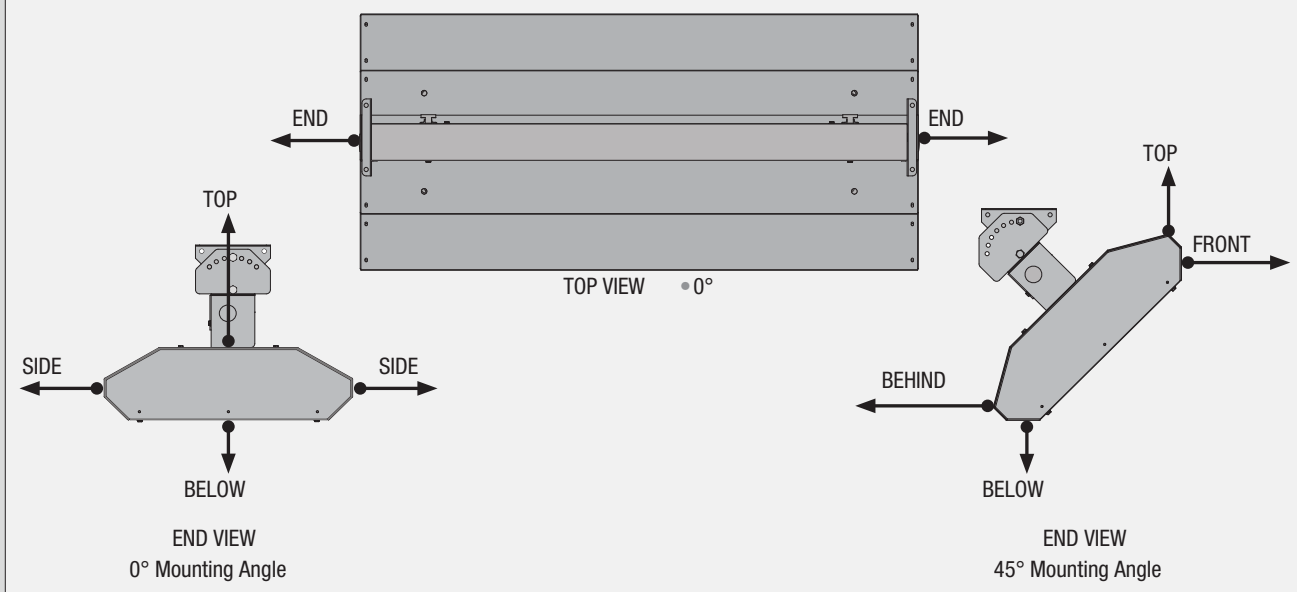

Commercial Radiant Heater RH Series

Accessories

*Highlighted models are in stock, others are available for special order.

MODEL	UPC	DESCRIPTION	WEIGHT
EL-1WG33	32576	Wire guard fits 33" single element.	4 lbs (1.8 kg)
EL-2WG24	32578	Wire guard fits 24" double element.	4 lbs (1.8 kg)
EL-2WG33	32579	Wire guard fits 33" double element.	5 lbs (2.3 kg)
EL-3WG33	32582	Wire guard fits 33" triple element.	7 lbs (3.2 kg)
EL-1FR33	32585	Recessed mount fits 33" single element	7 lbs (3.2 kg)
EL-2FR24	32587	Recessed mount fits 24" double element	7 lbs (3.2 kg)
EL-2FR33	32588	Recessed mount fits 33" double element	10 lbs (4.5 kg)
SMWC-36	32597	Variable heat controller 208/240 Volt; 15 Amp. 3600 Watts max.	3 lbs (1.5 kg)
EL-1WG24	32575	Wire guard fits 24" single element.	3 lbs (1.4 kg)
EL-1WG46	32577	Wire guard fits 46" single element.	5 lbs (2.3 kg)
EL-2WG46	32580	Wire guard fits 46" double element.	6 lbs (2.7 kg)
EL-3WG24	32581	Wire guard fits 24" triple element.	6 lbs (2.7 kg)
EL-3WG46	32583	Wire guard fits 46" triple element.	8 lbs (3.6 kg)
EL-1FR24	32584	Recessed mount fits 24" single element	5 lbs (2.3 kg)
EL-1FR46	32586	Recessed mount fits 46" single element	13 lbs (5.9 kg)
EL-2FR46	32589	Recessed mount fits 46" double element	15 lbs (6.8 kg)
EL-3FR24	32590	Recessed mount fits 24" triple element	16 lbs (7.3 kg)
EL-3FR33	32591	Recessed mount fits 33" triple element	19 lbs (8.6 kg)
EL-3FR46	32592	Recessed mount fits 46" triple element	21 lbs (9.5 kg)
PLQ	32593	Clearance Safety Limit Sign. 24 ga. aluminum 10" x 7". Sign is designed to be hung or adhered at clearance to combustible limit. Repeats clearance warnings.	1 lb (0.5 kg)
CE-40-24	32594	Contactor with enclosures. Ideal switching device for use with other control equipment. NEMA 1 Enclosures. Magnetic contactor with Load rating up to 600V Max., 3-Pole, 40 amps. 24 volt coil. Overload protection must be additionally provided.	8 lbs (3.6 kg)
CE-60-24	32595	Contactor with enclosures. Ideal switching device for use with other control equipment. NEMA 1 Enclosures. Magnetic contactor with Load rating up to 600V Max., 3-Pole, 60 amps. 24 volt coil. Overload protection must be additionally provided.	14 lb (6.4 kg)
SMWC-18	32596	Variable heat controller 120 Volt; 15 Amp. 1800 Watts max.	3 lbs (1.5 kg)
SCR208-30-1	32598	SCR controller. Single-phase 208/240 Volt. 30 Amp max. Enclosure Included	15 lbs (7kg)
SCR208-30-3	32599	SCR controller. Three-phase 208/240 Volt. 30 Amp max. Enclosure Included	40 lbs (18kg)
SCR208-80-3	32600	SCR controller. Three-phase 208/240 Volt. 80 Amp max. Enclosure Included	50 lbs (23kg)
SCR480-30-3	32601	SCR controller. Three-phase 480 Volt. 30 Amp max. Enclosure Included	40 lbs (18kg)
SCR480-80-3	32602	SCR controller. Three-Phase 480 Volt. 80 Amp max. Enclosure Included	50 lbs (23kg)
SCR-MA-AO	32603	Add-on option for SCR Series controllers to allow 4-20 ma control.	
SCR-DCV-AO	32604	Add-on option for SCR Series controllers to allow 2-10 Volts DC control.	
TH-1A66	32605	Heater thermostat with 40-85°F range. Double line break when positive off. For use on heaters up to 277V. 22 amps at 120 or 240 VAC non-inductive; 18 amps at 277 VAC non-inductive. Common thermostat when amperage permits.	2 lbs (0.9 kg)
VHC-3	32606	Variable heat controller suitable for up to a 3kW of infrared heater at 208- 240V supply. Integral ON/OFF switch. Fully adjustable power setting. High reliability triac used. Must be mounted in a protected area.	2 lbs (0.9 kg)
MS-3	32607	Motion sensor utilizes passive infrared technology to detect heat radiation of moving human bodies and will activate for a user-determined time period (2-18 mins.) Suitable for up to 3kW at 240V. Manual ON/OFF override. Waterproof (IP55). For wall or ceiling mount.	1 lb (0.5 kg)
TC-6	32608	Push button timer control. Suitable for up to 6kW of infrared heaters at 208-240V supply. Electronic soft start - extends lamp life. Tamper-proof Push Button. Fully adjustable time delay from 5 to 70 minutes. Red LED indicator when active. Waterproof (IP55 rated).	2 lbs (0.9 kg)
LCD-3H	32609	Energy saving snow switch allows heater operation only when required during snowfall and when temperatures remains closed for 1-hour hold-on time after precipitation has stopped. 24VAC required for operation and switches 24VAC signal. One device can operate multiple units. Must use in conjunction with a contactor.	2 lbs (0.9 kg)

Industrial Radiant Heater OK Series

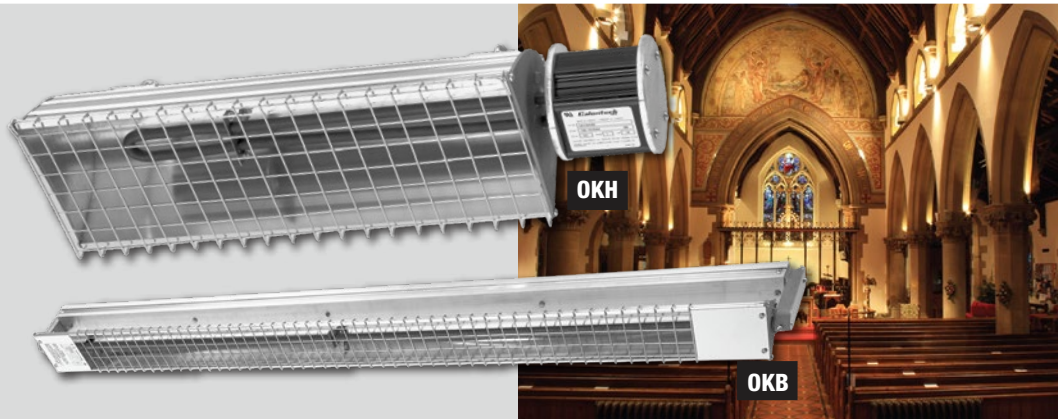

Model Code:

OKB 59 3 C6 -120V
A B C D E

A: Series
H = 45° Pattern
B = 60° Pattern
B: Length
C: Watts
D: 60° Reflector
E: Volts



- Radiant heat
- Incoloy® element
- Extruded aluminum housing
- Mounting hooks (OKH only)
- 60° spread
- Indoor or outdoor
- OKB: Anodized reflector
- OKB: Tilting swivel bracket
- OKB: Set screw adjustment
- OKB: Eyebolts for chain mounting
- OKB: Use 90°C wire
- OKH: Hairpin Incoloy® sheathed element
- OKH: Moisture resistant housing
- OKH: Sliding mounting pads

The OK Radiant Heater Series

The major benefit of infrared heating is its ability to transfer heat to a person or object without heating the surrounding air. The OKB is commonly used for indoor spot heating applications where a great amount of heat is not required and where the mounting height is relatively low. Example installations include churches, garages, and indoor pools. The OKH is excellent for indoor and outdoor areas with increased density. For example: racetracks and other outdoor stadiums, parking garage ramps, aircraft hangars and high bay industrial buildings.

Ordering Information

MODEL	PATTERN SPREAD	WATTS	UPC	TYPE	VOLTS	AMPS	MOUNTING HEIGHT	COVERAGE			LENGTH	WIDTH	HEIGHT	WT. LBS.
								WIDTH	LENGTH	SQ. FT.				
OKH191H6R-120V	45°	1600	11650	Hairpin Element	120	13.3	7 ft.	4.6"	5.6"	25.7	23.5"	7"	5"	11
							8 ft.	5.8"	6.6"	37.8				
							9 ft.	6.9"	7.6"	52.3				
OKH191H6R-240V	45°	1600	11655	Hairpin Element	240	6.6	10 ft.	8.1"	8.6"	69.1	23.5"	7"	5"	11
							11 ft.	9.2"	9.6"	88.1				
OKB593C6-208V	60°	3000	11665	Single Element	208	14.4	8 ft.	5.8"	9.2"	52.9	61.5"	4.25"	5"	4
							9 ft.	6.9"	10.2"	70.4				
							10 ft.	8.1"	11.2"	90.2				
OKB593C6-240V	60°	3000	11660	Single Element	240	12.5	11 ft.	9.2"	12.2"	112.2	61.5"	4.25"	5"	4
							12 ft.	10.4"	13.2"	136.6				
OKB593C6-480V	60°	3000	11670	Single Element	480	6.25	13 ft.	11.5"	14.2"	163.3				
OKB595E6-208V	60°	5000	11680	Double Element	208	24	10 ft.	8.1"	11.2"	90.2	61.5"	4.25"	5"	4
							11 ft.	9.2"	12.2"	112.2				
							12 ft.	10.4"	13.2"	136.6				
OKB595E6-240V	60°	5000	11675	Double Element	240	20.8	13 ft.	11.5"	14.2"	163.3	61.5"	4.25"	5"	4
							14 ft.	12.7"	15.2"	192.3				
							15 ft.	13.8"	16.2"	223.6				
OKB595E6-480V	60°	5000	11685	Double Element	480	10.4	16 ft.	15"	17.2"	257.1				

Engineering Specifications

Contractor shall supply and install OK Series radiant heaters by King Electrical Mfg. Company. Heaters shall be of the wattage and voltage as indicated on the plans.

Element: Shall be of Ni-Chrome wire embedded in Magnesium Oxide with an Incoloy® metal sheath.

Junction Box: Will be extruded Aluminum and provided with heater O-ring seals which may be used to seal off junctionbox from moisture (included on OKH units only). OKB units shall have single or dual Incoloy® elements and shall swivel to direct radiant pattern to best meet the needs of application. For indoor use only.

Mounting: Shall be provided by means of 2 eyehooks per heater.

Industrial Radiant Heater OK Series

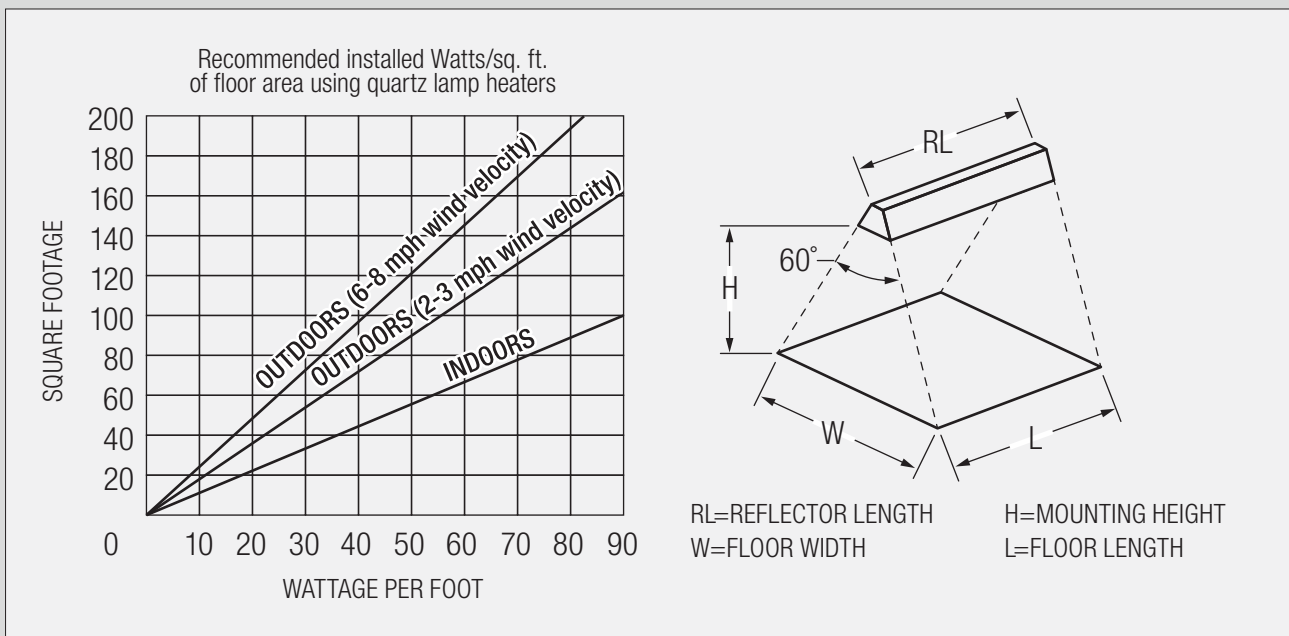

Use the table above to choose the proper mounting height, heated space coverage and desired temperature rise. For example: a warehouse that is 40°F with a work space area of 135ft² needs to be 60°F to make workers comfortable. This requires a temperature rise of 20°F. Referring to the table we find that the OKB at 3000 Watts mounted at 12 feet would provide the required coverage. Note the coverage area and temperature rise are calculated at 3 feet above floor level. This means a heater mounted 10 feet high from the floor would produce values in the table measured 7 feet vertically down from the fixture.

DANGER: Take precautions to ensure combustible materials are kept a safe distance away, 24 inches minimum.

Minimum Space Clearings

WALL	END	CEILING	FLOOR	BETWEEN
24"	24"	24"	72"	36"

Pumphouse Heater U Series



Stainless shown



Model Code:

U 24 10 SS
A B C D

A: Series
B: 12 - 120V 20- 208V
24 - 240V
C: Watts (1000)
D: -SS Stainless Steel



Rated for damp locations

- ETL listed for use in damp locations
- Available in textured gray or stainless steel
- Designed to meet requirements outlined in ASSE-1060
- Built-in thermostat with frost protection (40° to 90°F)
- Stainless steel element
- Standard baked enamel protective coating
- Built in mounting bracket
- Convection/Radiant heat
- Vertical or horizontal mount
- 1-year limited warranty



The U Series Pumphouse Heater

The U Series heater is designed to reduce moisture from mechanical equipment and keep pumps, valves, and farm machinery from freezing. Having the radiant heat absorbed by the metal equipment makes this heater more effective than convection heaters. The built-in thermostat turns off when the ambient temperature is safely above freezing. An optional 304 Stainless Steel (Add-SS to the model number) version helps prevent corrosion associated with high moisture locations like pump houses. A steel guard helps keep foreign objects away from the element. This heater is simple and reliable with no moving parts to wear out or maintain, making it an inexpensive choice for freeze protection. Specifically designed to operate in both vertically and horizontally positions.

Ordering Information

	MODEL	UPC#	VOLTAGE	WATTAGE	WEIGHT lbs
120V	U2425**	12612	120	62	4
	U2450**	12615	120	125	4
	U2475**	12618	120	187	4
	U24100**	12621	120	250	4
	U1250**	12605	120	500	4
	U1275**	12606	120	750	4
240V	U12100**	12609	120	1000	4
	U2425**	12612	240/208*	250/187	4
	U2450**	12615	240/208*	500/375	4
	U2475**	12618	240/208*	750/563	4
	U24100**	12621	240/208*	1000/750	4

**Add -SS for stainless steel construction

*Dual rated heaters will draw 13% less amps and 25% less wattage when operated at 208V.

Dimensional Data

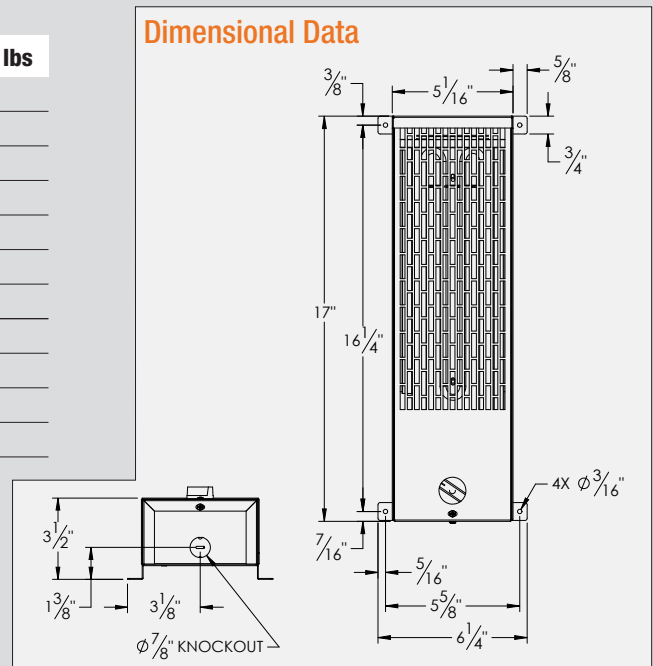

Engineering Specifications

Contractor shall supply and install U Pump House series radiant heaters manufactured by King Electrical Mfg. Company. Heaters shall be of the wattage and voltage as indicated on the plans.

Element: 304 or 840 Stainless Steel.

Thermostat: Built-in snap action with a range of 40° to 90°F.

Safety Limit: Capillary tube running the full length of the element provides over-temperature protection then automatically resets when temperature drops.

Enclosure: Steel case with an expanded steel metal element shield (optional 20 gauge 304 Stainless Steel on -SS model).

Safety Standard: cETLus

Compact Fan Forced Cabinet Heater KCF Series



Model Code:

KCF 2/3/4 -24 20 -1 -R -T -DS1
 A B C D E F G H

A: Series
B: Length
C: 20 - 208V 24 - 240V
27 - 277V 48 - 480V
D: Watts (20=2000 - 50=5000)
E: -1 single phase -3 three phase
F: Recess or Surface mount
G: SP Stat
H: Double Pole Disconnect Switch

- Fan-Forced heat
- Aluminum fin element
- Squirrel cage blower
- 1 or 3-phase
- Standard color: almond
- Ceramic element
- 18 gauge cabinet
- Capillary tube limit
- Powder-coated
- 5-year limited warranty



The KCF Series Cabinet Heater



The King heavy KCF cabinet heater can be placed almost anywhere. Typical uses are hall or entryways where a deep cabinet heater would be too intrusive. The slim design is great for schools, office, air terminals, auditoriums, apartments, restaurants, churches, factory's, theaters and other locations where a clean impact resistant 18 gauge construction and entry way or comfort heating is needed. The KCF uses the time tested ceramic core heating elements that King developed over 50 years ago and have a very long life. Available in a slim 4" surface mount or the recess in wall installation. A sub-base is available when installing close to the floor to fill the gap. Thermostats, Contactors and Disconnect switches are available as options. Textured powder coated finish in an almond color. KCF model adds quiet tangential fans in the bottom of the cabinet to help move the heated air out of the cabinet. KCF model is not for residential use unless you add the Manual reset limit option.

Ordering Information *Add suffix -1 for single phase, -3 for three phase *Add suffix -R for recessed mount, -S for surface mount

	MODEL	VOLTS	WATTS	(1ph) AMPS (3ph)	BTUH(000)	#of BLOWERS	CFM	LENGTH	SHIP WEIGHT lbs
208V	KCF2-2020	208	2000	9.6 5.6	6.8	1	70	24"	35
	KCF3-2030	208	3000	14.4 8.3	10.2	2	140	36"	45
	KCF4-2040	208	4000	19.2 11.1	13.6	3	210	48"	55
	KCF4-2050	208	5000	24 13.9	17	3	210	48"	55
240V	KCF2-2420	240	2000	8.3 4.8	6.8	1	70	24"	35
	KCF3-2430	240	3000	12.5 7.2	10.2	2	140	36"	45
	KCF4-2440	240	4000	16.7 9.6	13.6	3	210	48"	55
	KCF4-2450	240	5000	20.8 12.0	17	3	210	48"	55
277V	KCF2-2720	277	2000	7.2 n/a	6.8	1	70	24"	35
	KCF3-2730	277	3000	10.3 n/a	10.2	2	140	36"	45
	KCF4-2740	277	4000	14.4 n/a	13.6	3	210	48"	55
	KCF4-2750	277	5000	18 n/a	17	3	210	48"	55
480V	KCF2-4820	480	2000	4.2 2.4	6.8	1	70	24"	35
	KCF3-4830	480	3000	6.5 3.6	10.2	2	140	36"	45
	KCF4-4840	480	4000	8.3 4.8	13.6	3	210	48"	55
	KCF4-4850	480	5000	10.4 6	17	3	210	48"	55

Engineering Specifications

Contractor shall supply and install KCF Series cabinet heaters manufactured by King Electrical Mfg. Company. Heaters shall be of the wattage and voltage as indicated on the plans.

Construction: Heaters shall be constructed in 18 gauge galvanized Steel with epoxy powder-coated manufacturer's standard finish. A louvered front cover with intake and outlet grille will protect element area and provide ample air flow to dissipate heated air.

Element: The superior performance comes from the proven technology of the ceramic thermal storage heater core. A 7/8" diameter aluminum tube is filled with a special high density ceramic that stores the thermal energy. The oversized fins (4.875 in²) are made from durable (0.015" thick) high grade aluminum which produces better heat transfer than other elements. The benefit of the technology comes when the thermostat is turned off and the element continues to radiate heat. It also reduces temperature swings by heating and cooling more evenly. A fired refractory ceramic core with two large diameter Nickel Chromium

coils attached with high temperature stainless connectors and stranded Nickel wire, terminated in a junctionbox.

Controls: A built-in thermal cutout shall automatically shut off the heater in case of overheating. A built-in thermostat for temperature control will have a range from 40° - 95°F and be of the high accuracy capillary tube-type. Disconnect switch and contactors will be provided if necessary.

Blower and Motor: Up to 3 tangential cylindrical blowers, delivering 70 CFM each, shall be driven by a shaded pole, permanently lubricated, C-frame type motor with impedance protection and sealed bearings. Motors shall be the same voltage as the heater. All 480V units use 277V motors and contactors. This requires a neutral connection.

Approvals: cULus

Compact Fan Forced Cabinet Heater KCF Series

Mounting Data

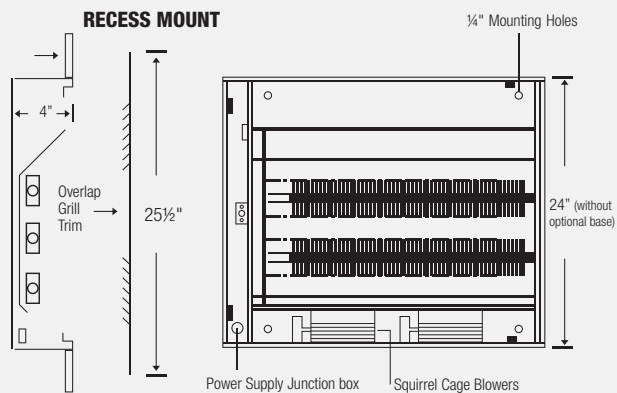
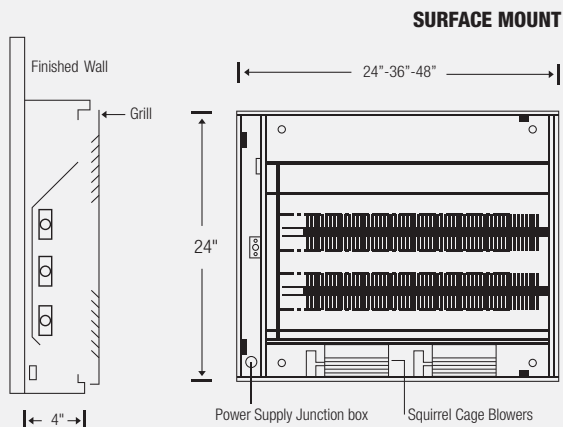

MOUNTING NOTE: 1" minimum mounting height from finished floor to allow clearance for the grill overlap.

Control Options

- A line voltage terminal block can be provided for wiring to a remote line voltage thermostat.
- A power contactor with line voltage coil can be provided to remotely switch the heater.
- A power contactor and 24V transformer can be provided to remotely switch the heater.
- A 3-position switch can be provided for manual HEAT/FAN/OFF control.
- A 2-Pole Disconnect switch can be provided for 1-Phase heaters.
- A 3-Pole Disconnect can be provided for 3-Phase heaters.
- A floor sub-base can be provided for direct floor contact.
- A built-in 1-Pole thermostat can be provided for convenience.
- A built-in 2-Pole thermostat can be provided for convenience.
- A tamperproof built-in thermostat can be provided without a knob, temperature adjustments are made with a screw driver.

Dimensional Data

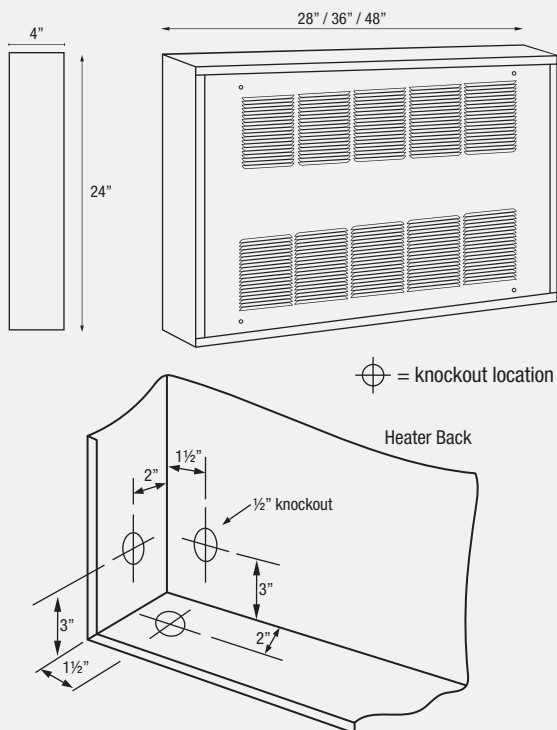

Control Options

ADD SUFFIX	DESCRIPTION
-RT	Line Voltage Terminal Block
-CX	Power Contactor
-RT24	24 Volt Contactor & Transformer
-3PS	3-Position Switch
-DS1	Double Pole Disconnect Switch (1-Phase)
-DS3	Three Pole Disconnect Switch (3-Phase)
-SB-24	Subbase - 24", 2" tall, 3" deep
-SB-36	Subbase - 36", 2" tall, 3" deep
-SB-48	Subbase - 48", 2" tall, 3" deep
-T	25 Amp Single Pole Thermostat w/Knob
-T2	25 Amp Double Pole Thermostat w/Knob
-TP	25 Amp Tamperproof (slotted shaft), single pole

High Mass Ceramic Element

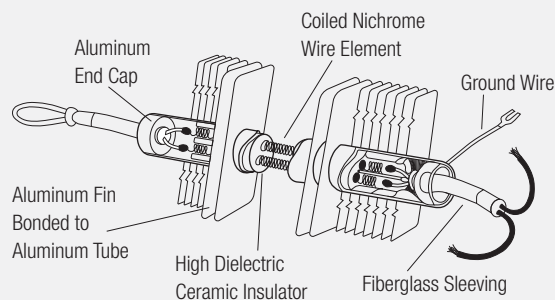

Safe Touch Cabinet Heater KCF Series



SafeTouch™

Model Code:

KCF 2/3/4 -24 20 -1 -R -T -DS1
A B C D E F G H

- A: Series
- B: Length
- C: 20 - 208V 24 - 240V
27 - 277V 48 - 480V
- D: Watts (20=2000 - 50=5000)
- E: -1 single phase -3 three phase
- F: Recess or Surface mount
- G: SP Stat
- H: Double Pole Disconnect Switch

- 125°F max surface temperature
- Fan-Forced heat
- Ceramic element
- Aluminum fin element
- 18 gauge cabinet
- Squirrel cage blower
- Capillary tube limit
- 1 or 3-phase
- Powder-coated
- Standard color: almond
- 5-year limited warranty



The KCF Series Safe Touch Cabinet Heater

The KCF Safe Touch heater is intended for areas that are required to have surface temperatures below 125 degrees F,

These areas are typically, day care centers, memory care centers, common areas where wheel chair patients may be placed or anywhere a temperature of an electric heater over 125 degrees could cause someone to accidentally burn themselves over time. Many older care centers have implemented this type of heater replacing the old style high wattage baseboards as it has been enforced by inspectors and required by code to keep their patients safe. Heavy duty front covers and our Ceramic Core heating element makes this a long lasting heater with virtually no maintenance required. Optional: Sub-base for mounting close to the floor, inbuilt thermostat factory or tamperproof thermostat may be installed. Heaters can be ganged together to work on one thermostat if higher output is required. Not for residential use unless the manual reset option is added.

Ordering Information

*Add suffix -1 for single phase, -3 for three phase

*Add suffix -R for recessed mount, -S for surface mount

	MODEL	VOLTS	WATTS	(1ph) AMPS (3ph)	BTUH	#of BLOWERS	CFM	LENGTH	SHIP WEIGHT lbs
208V	KCF2-2005	208	500	2.4 1.4	1.7	1	70	24"	35
	KCF3-2007	208	750	3.6 2.1	2.6	1	70	36"	35
	KCF4-2015	208	1500	7.2 4.2	5.1	2	140	48"	45
	KCF4-2020	208	2000	9.6 5.6	6.8	3	210	48"	55
240V	KCF2-2405	240	500	2.1 1.2	1.7	1	70	24"	35
	KCF3-2407	240	750	3.1 1.8	2.6	1	70	36"	35
	KCF4-2415	240	1500	6.3 3.6	5.1	2	140	48"	45
	KCF4-2420	240	2000	8.3 4.8	6.8	3	210	48"	55
277V	KCF2-2705	277	500	1.8 n/a	1.7	1	70	24"	35
	KCF3-2707	277	750	2.7 n/a	2.6	1	70	36"	35
	KCF4-2715	277	1500	5.4 n/a	5.1	2	140	48"	45
	KCF4-2720	277	2000	7.2 n/a	6.8	3	210	48"	55
480V	KCF2-4805	480	500	1.0 0.6	1.7	1	70	24"	35
	KCF3-4807	480	750	1.6 0.9	2.6	1	70	36"	35
	KCF4-4815	480	1500	3.1 1.8	5.1	2	140	48"	45
	KCF4-4820	480	2000	4.2 2.4	6.8	3	210	48"	55

*Refer to KCF for dimensions, control options, mounting data.

Engineering Specifications

Contractor shall supply and install KCF Series Safe Touch cabinet heaters manufactured by King Electrical Mfg. Company. Heaters shall be of the wattage and voltage as indicated on the plans.

Construction: Heaters shall be constructed in 18 gauge galvanized Steel with epoxy powder-coated manufacturer's standard finish. A louvered front cover with intake and outlet grille will protect element area and provide ample air flow to dissipate heated air.

Element: The superior performance comes from the proven technology of the ceramic thermal storage heater core. A 7/8" diameter aluminum tube is filled with a special high density ceramic that stores the thermal energy. The oversized fins (4.875 in²) are made from durable (0.015" thick) high grade aluminum which produces better heat transfer than other elements. The benefit of the technology comes when the thermostat is turned off and the element continues to radiate heat. It also reduces temperature swings by heating and cooling more evenly. A fired refractory ceramic core with two large diameter Nickel Chromium

coils attached with high temperature stainless connectors and stranded Nickel wire, terminated in a junctionbox.

Controls: A built-in thermal cutout shall automatically shut off the heater in case of overheating. A built-in thermostat for temperature control will have a range from 40°- 95°F and be of the high accuracy capillary tube-type. Disconnect switch and contactors will be provided if necessary.

Blower and Motor: Up to 3 tangential cylindrical blowers, delivering 70 CFM each, shall be driven by a shaded pole, permanently lubricated, C-frame type motor with impedance protection and sealed bearings. Motors shall be the same voltage as the heater. All 480V units use 277V motors and contactors. This requires a neutral connection.

Approvals: cULus

Compact Convection Cabinet Heater KCC Series



Model Code:

KCC	2/3/4	-24	20	-1	-R	-T	-DS1
A	B	C	D	E	F	G	H

A: Series
B: Length
C: 20 - 208V 24 - 240V 27 - 277V 48 - 480V
D: Watts (20=2000 - 50=5000)
E: -1 single phase -3 three phase
F: Recess or Surface mount
G: SP Stat
H: Double Pole Disconnect Switch

- Convection heat
- Quiet running
- Aluminum fin element
- Powder-coated
- Standard color: almond
- Ceramic element
- 18 gauge cabinet
- 1 or 3-phase
- Capillary tube limit
- 5-year limited warranty



The KCC Series Cabinet Heater



The King heavy KCC cabinet heater can be placed almost anywhere. Typical uses are hall or entryways where a deep cabinet heater would be too intrusive. The slim design is great for schools, office, air terminals, auditoriums, apartments, restaurants, churches, factory's, theaters and other locations where a clean impact resistant 18 gauge construction and entry way or comfort heating is needed. The KCC uses the time tested ceramic core heating elements that King developed over 50 years ago and have a very long life. Available in a slim 4" surface mount or the recess in wall installation. A sub-base is available when installing close to the floor to fill the gap. Thermostats, Contactors and Disconnect switches are available as options. Textured powder coated finish in an almond color.

Ordering Information *Add suffix -1 for single phase, -3 for three phase *Add suffix -R for recessed mount, -S for surface mount

	MODEL	VOLTS	WATTS	(1ph) AMPS	(3ph)	BTUH(000)	LENGTH	SHIP WEIGHT lbs
208V	KCC2-2020	208	2000	9.6	5.6	6.8	24"	30
	KCC3-2030	208	3000	14.4	8.3	10.2	36"	40
	KCC4-2040	208	4000	19.2	11.1	13.6	48"	50
	KCC4-2050	208	5000	24	13.9	17	48"	50
240V	KCC2-2420	240	2000	8.3	4.8	6.8	24"	30
	KCC3-2430	240	3000	12.5	7.2	10.2	36"	40
	KCC4-2440	240	4000	16.7	9.6	13.6	48"	50
	KCC4-2450	240	5000	20.8	12.0	17	48"	50
277V	KCC2-2720	277	2000	7.2	n/a	6.8	24"	30
	KCC3-2730	277	3000	10.3	n/a	10.2	36"	40
	KCC4-2740	277	4000	14.4	n/a	13.6	48"	50
	KCC4-2750	277	5000	18	n/a	17	48"	50
480V	KCC2-4820	480	2000	4.2	2.4	6.8	24"	30
	KCC3-4830	480	3000	6.5	3.6	10.2	36"	40
	KCC4-4840	480	4000	8.3	4.8	13.6	48"	50
	KCC4-4850	480	5000	10.4	6	17	48"	50

Engineering Specifications

Contractor shall supply and install KCC Series cabinet heaters manufactured by King Electrical Mfg. Company. Heaters shall be of the wattage and voltage as indicated on the plans.

Construction: Heaters shall be constructed in 18 gauge galvanized Steel with epoxy powder-coated manufacturer's standard finish. A louvered front cover with intake and outlet grille will protect element area and provide ample air flow to dissipate heated air.

Element: The superior performance comes from the proven technology of the ceramic thermal storage heater core. A 7/8" diameter aluminum tube is filled with a special high density ceramic that stores the thermal energy. The oversized fins (4.875 in²) are made from durable (0.015" thick) high grade aluminum which produces better heat transfer than other elements. The benefit of the technology comes when the thermostat

is turned off and the element continues to radiate heat. It also reduces temperature swings by heating and cooling more evenly. A fired refractory ceramic core with two large diameter Nickel Chromium coils attached with high temperature Nickel connectors and stranded Nickel wire, terminated in a junctionbox.

Controls: A built-in thermal cutout shall automatically shut off the heater in case of overheating. A built-in thermostat for temperature control will have a range from 40°- 95°F and be of the high accuracy capillary tube-type. Disconnect switches in junctionbox will be provided if necessary.

Approvals: cULus

Compact Convection Cabinet Heater KCC Series

Mounting Data

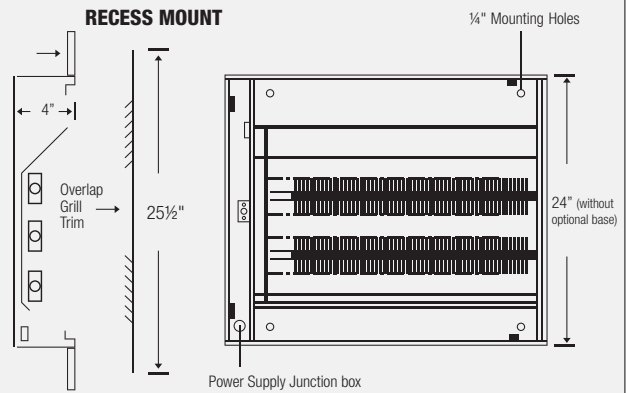
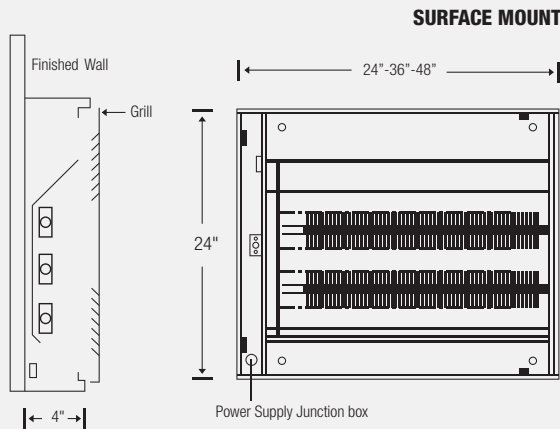

MOUNTING NOTE: 1" minimum mounting height from finished floor to allow clearance for the grill overlap.

Control Options

- A line voltage terminal block can be provided for wiring to a remote line voltage thermostat.
- A power contactor with line voltage coil can be provided to remotely switch the heater.
- A power contactor and 24V transformer can be provided to remotely switch the heater.
- A 2-Pole Disconnect switch can be provided for 1-Phase heaters.
- A 3-Pole Disconnect can be provided for 3-Phase heaters.
- A floor sub-base can be provided for direct floor contact.
- A built-in 1-Pole thermostat can be provided for convenience.
- A built-in 2-Pole thermostat can be provided for convenience.
- A tamperproof built-in thermostat can be provided without a knob, temperature adjustments are made with a screw driver.

Dimensional Data

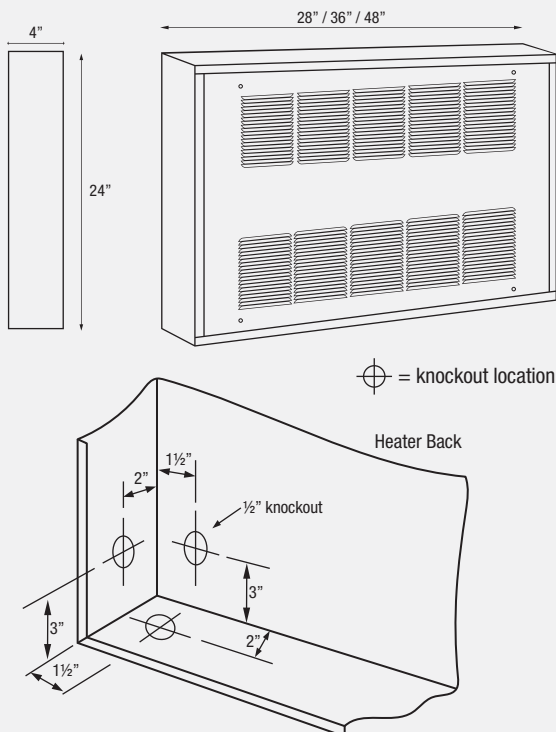

Control Options

ADD SUFFIX	DESCRIPTION
-RT	Line Voltage Terminal Block
-CX	Power Contactor
-RT24	24 Volt Contactor & Transformer
-DS1	Double Pole Disconnect Switch (1-Phase)
-DS3	Three Pole Disconnect Switch (3-Phase)
-SB-24	Subbase - 24", 2" tall, 3" deep
-SB-36	Subbase - 36", 2" tall, 3" deep
-SB-48	Subbase - 48", 2" tall, 3" deep
-T	25 Amp Single Pole Thermostat w/Knob
-T2	25 Amp Double Pole Thermostat w/Knob
-TP	25 Amp Tamperproof (slotted shaft), single pole

Highmass Ceramic Element

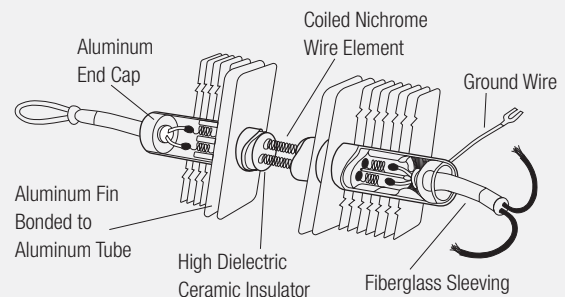

Commercial Cabinet Heater KCA Series



Model Code:

KCA	20	02	-3
A	B	C	D

A: Series
B: Volts 20-208V 24-240V
27-277V 48-480V
C: Watts (2000-24000)
D: -1 phase -3 phase



- Tubular heating element with fins
- 240V/208V factory-lubricated motor (1/15 hp)
- Direct drive, variable speed squirrel-cage fan operating at 48dBA at low speed and 50 dBA at high speed
- 208V, 240V, 277V, 347V, 480V, 600V, 1 or 3-Phase
- 1 year warranty against defects
- Available in 4 lengths: 28" (711mm), 48" (1219"), 66" (1676mm), 80" (2032mm)
- High-limit temperature control with automatic reset
- Field changeable air inlet and outlet
- Maximum mounting height: 10 ft. (3m)
- Standard color: white (-BW)
- Fan delay
- 18 gauge steel
- Extruded aluminum grill
- 240V control circuit included
- Wide range of control options
- Multi-position mounting (surface, semi-recessed, recessed)

The KCA Series Cabinet Heater

The KCA Cabinet Unit Heater offers a wide range of power ratings, voltage and control options in four cabinet sizes.

Most installations benefit from the heater's custom advantages. The cabinet heater can be mounted on the floor, wall or ceiling. It can also be recessed (wall or ceiling) as required. The fans are powered by 2-speed motors (Hi / Low option) with permanently lubricated sleeve bearings for many years of trouble-free service. The blower wheel is mounted directly on the motor shaft, which reduces the noise level. No belts or bearing blocks are required for the blowers.

Accessories

MODEL	DESCRIPTION
Sub-base 2"	
KCA-SO-28	28" (711 mm) cabinet
KCA-SO-48	48" (1219 mm) cabinet
KCA-SO-66	66" (1676 mm) cabinet
KCA-SO-80	80" (2032 mm) cabinet
Recess trim kit 2"	
KCA-CR-28	28" (711 mm) cabinet
KCA-CR-48	48" (1219 mm) cabinet
KCA-CR-66	66" (1676 mm) cabinet
KCA-CR-80	80" (2032 mm) cabinet
Air filter (wall mount only)	
KCA-FI-28	28" (711 mm) cabinet
KCA-FI-48	48" (1219 mm) cabinet
KCA-FI-66	66" (1676 mm) cabinet
KCA-FI-80	80" (2032 mm) cabinet
Washable air filter (wall installation only)	
KCA-FIW-28	28" (711 mm) cabinet
KCA-FIW-48	48" (1219 mm) cabinet
KCA-FIW-66	66" (1676 mm) cabinet
KCA-FIW-80	80" (2032 mm) cabinet
Special back plate (kit)	
KCA-DU-28	28" (711 mm) cabinet
KCA-DU-48	48" (1219 mm) cabinet
KCA-DU-66	66" (1676 mm) cabinet
KCA-DU-80	80" (2032 mm) cabinet

Dimensional Data

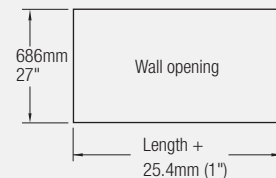
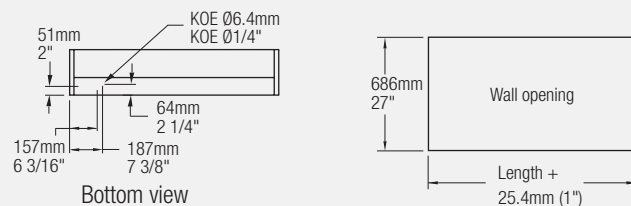

Bottom view

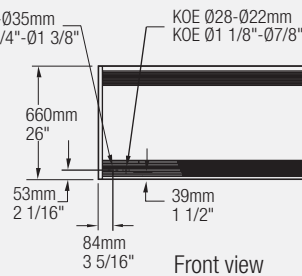

Front view

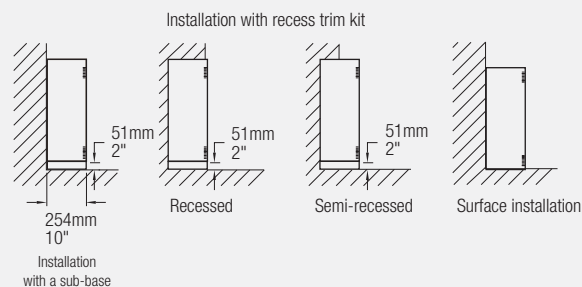

Commercial Cabinet Heater KCA Series

Ordering Information

MODEL	VOLTS	(Hi)	WATTS	(Lo)	(Hi)	CFM	(Lo)	LENGTH	SHIP WEIGHT lbs
KCAU2002-3*	208 (3ph)	2000		1333	250	200		28 in	115
KCAU2003-3*	208 (3ph)	3000		1000	250	200		28 in	115
KCAU2004-3*	208 (3ph)	4000		2667	250	200		28 in	115
KCAU2005-3*	208 (3ph)	5000		3333	250	200		28 in	115
KCAU2006-3*	208 (3ph)	6000		4000	250	200		28 in	115
KCAU2008-3*	208 (3ph)	8000		5333	500	400		48 in	146
KCAU2010-3	208 (3ph)	10000		6667	500	400		48 in	146
KCAU2012-3	208 (3ph)	12000		8000	500	400		48 in	146
KCAU2015-3	208 (3ph)	15000		10000	750	600		66 in	210
KCAU2018-3	208 (3ph)	18000		12000	750	600		66 in	210
KCAU2020-3	208 (3ph)	20000		13333	1000	800		80 in	240
KCAU2024-3	208 (3ph)	24000		16000	1000	800		80 in	240
KCAU2402-1	240 (1ph)	2000		1333	250	200		28 in	115
KCAU2403-1	240 (1ph)	3000		1000	250	200		28 in	115
KCAU2404-1	240 (1ph)	4000		2667	250	200		28 in	115
KCAU2405-1	240 (1ph)	5000		3333	250	200		28 in	115
KCAU2406-1	240 (1ph)	6000		4000	250	200		28 in	115
KCAU2408-1	240 (1ph)	8000		5333	500	400		48 in	146
KCAU2410-1	240 (1ph)	10000		6667	500	400		48 in	146
KCAU2412-1	240 (1ph)	12000		8000	500	400		48 in	146
KCAU2415-1	240 (1ph)	15000		10000	750	600		66 in	210
KCAU2418-1	240 (1ph)	18000		12000	750	600		66 in	210
KCAU2420-1	240 (1ph)	20000		13333	1000	800		80 in	240
KCAU2424-1	240 (1ph)	24000		16000	1000	800		80 in	240
KCAU2402-3	240 (3ph)	2000		1333	250	200		28 in	115
KCAU2403-3	240 (3ph)	3000		1000	250	200		28 in	115
KCAU2404-3	240 (3ph)	4000		2667	250	200		28 in	115
KCAU2405-3	240 (3ph)	5000		3333	250	200		28 in	115
KCAU2406-3	240 (3ph)	6000		4000	250	200		28 in	115
KCAU2408-3	240 (3ph)	8000		5333	500	400		48 in	146
KCAU2410-3	240 (3ph)	10000		6667	500	400		48 in	146
KCAU2412-3	240 (3ph)	12000		8000	500	400		48 in	146
KCAU2415-3	240 (3ph)	15000		10000	750	600		66 in	210
KCAU2418-3	240 (3ph)	18000		12000	750	600		66 in	210
KCAU2420-3	240 (3ph)	20000		13333	1000	800		80 in	240
KCAU2424-3	240 (3ph)	24000		16000	1000	800		80 in	240
KCAU2702-1	277 (1ph)	2000		1333	250	200		28 in	115
KCAU2703-1	277 (1ph)	3000		1000	250	200		28 in	115
KCAU2704-1	277 (1ph)	4000		2667	250	200		28 in	115
KCAU2705-1	277 (1ph)	5000		3333	250	200		28 in	115
KCAU2706-1	277 (1ph)	6000		4000	250	200		28 in	115
KCAU2708-1	277 (1ph)	8000		5333	500	400		48 in	146
KCAU2710-1	277 (1ph)	10000		6667	500	400		48 in	146
KCAU2712-1	277 (1ph)	12000		8000	500	400		48 in	146
KCAU4802-3*	480 (3ph)	2000		1333	250	200		28 in	115
KCAU4803-3*	480 (3ph)	3000		1000	250	200		28 in	115
KCAU4804-3*	480 (3ph)	4000		2667	250	200		28 in	115
KCAU4805-3*	480 (3ph)	5000		3333	250	200		28 in	115
KCAU4806-3*	480 (3ph)	6000		4000	250	200		28 in	115
KCAU4808-3*	480 (3ph)	8000		5333	500	400		48 in	146
KCAU4810-3*	480 (3ph)	10000		6667	500	400		48 in	146
KCAU4812-3*	480 (3ph)	12000		8000	500	400		48 in	146
KCAU4815-3*	480 (3ph)	15000		10000	750	600		66 in	210
KCAU4818-3*	480 (3ph)	18000		12000	750	600		66 in	210
KCAU4820-3*	480 (3ph)	20000		13333	1000	800		80 in	240
KCAU4824-3*	480 (3ph)	24000		16000	1000	800		80 in	240

Add suffix (-A) for almond, (-AE) for Metallic Silver, (-BG) for Beige-Grey, (-BZ) for Bronze, (-CM) for Metallic Charcoal, (-NR) for Textured Black, (-AL) for Aluminum, (-NL) for Semi-Gloss Black
 * 1-ph available upon request, 2000W to 6000W only (change the 3 to a 1 in the product number).

Commercial Cabinet Heater KCA Series

Mounting Applications

Top

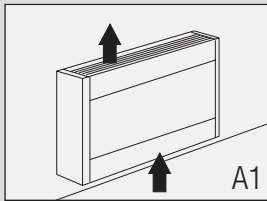

A1

Bottom

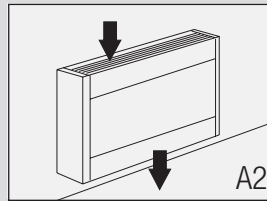

A2

Ceiling

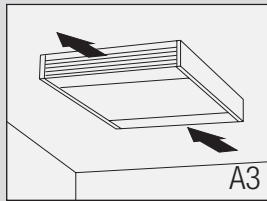

A3

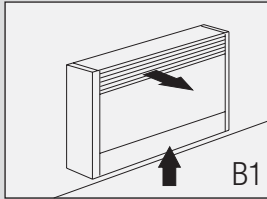

B1

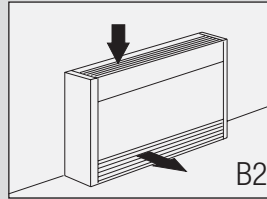

B2

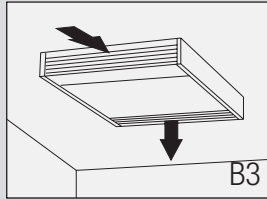

B3

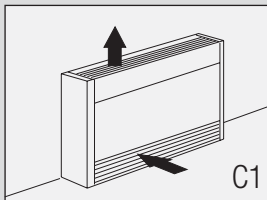

C1

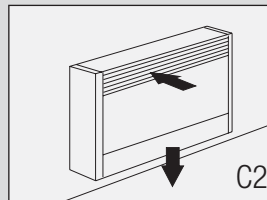

C2

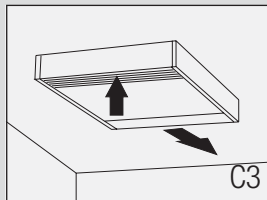

C3

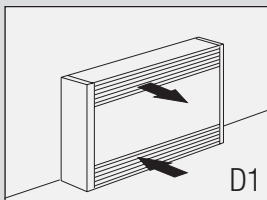

D1

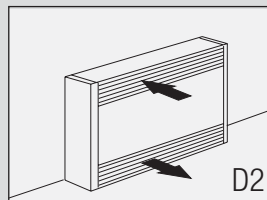

D2

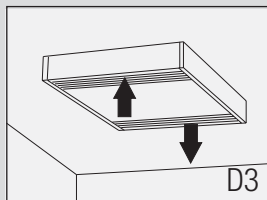

D3

If Mounting Configuration is not Specified on the Order, D1 will be used as our standard

Ceiling

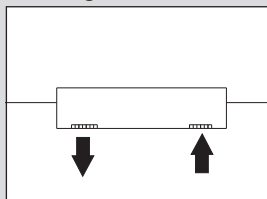

Semi-recessed

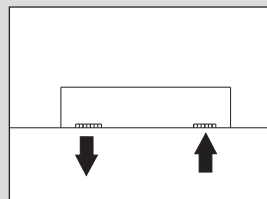

Recessed

(*D-type mounting only*)

Wall

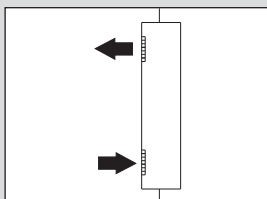

Semi-recessed

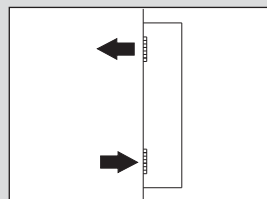

Recessed

Control Options

MODEL	DESCRIPTION
KCA-RT	24V relay with transformer
KCA-R	24V relay without transformer
Product no-RV	Factory Installed 24V fan relay
Product no-RHL	Factory Installed 24V relay (Hi / Lo)
Product no-ROO	Factory Installed 24V relay (On / Stand by)
KCA-T-AV	Single-pole tamperproof thermostat
Product no-T2S	2-Stage tamperproof thermostat (Factory Installed Only)
Product no-DIS40	Factory Installed disconnect switch, 40A
Product no-DIS80	Factory Installed disconnect switch, 80A
Product no-IV	Factory Installed On / Auto switch
Product no-HL	Factory Installed Hi / Low switch
KCA-00*	On / Off switch
Product no-AF***	Fresh air inlet
Product no-AFM***	Power operated fresh air inlet

***Do not install built-in thermostat with these options

Architectural Convection Cabinet Heater KLA Series



Model Code:

KLA	20	15	-3	-690
A	B	C	D	E
A: Series				
B: Volts (12=120, 20=208, 24=240, 27=270)				
C: Watts (15=1500)				
D: Phase (1 or 3)				
E: Length in mm (-690=690mm)				

- 3 steel tubular heating elements with aluminum fins
- Front fresh air inlet; top warm air outlet or front (-FR)
- Standard Watt density of 1000W/ft. (3280W/m)
- Low Watt density of 750W/ft. (2460W/m)
- Linear high-limit temperature control with automatic reset
- Standard color: bright white (optional almond color available)
- 20 Gauge Steel Cabinet
- Available in 120, 208, 240, 277 or 600 Volts, 1 Or 3 phase
- 1-year warranty against defects



The KLA Series Cabinet Heater

Features a maximum power rating of 6000W, the KLA unit is designed for large commercial spaces. This natural convection unit with its architectural design is perfect for areas requiring lots of heat without fan noise. Several options are also available for wall-to-wall installation. In addition, units with front warm air outlet (option -FR) can be completely recessed. Perfect for hospitals or daycares. King highly recommends use of a wall thermostat for greater comfort. **NOT FOR RESIDENTIAL USE.**

Ordering Information Standard models (1000W/ft)

WATTS	240V/208V	208V (1 ph)	UPC	208V (3 ph)	UPC	240V/208V	UPC	277V	UPC	LENGTH	WT. (lbs.)
2000	2000/1500W	KLA2020-1	31108	KLA2020-3	31118	KLA2420-1	31128	KLA2720-1	31138	27 3/16	37
3000	3000/2250W	KLA2030-1	31110	KLA2030-3	31120	KLA2430-1	31130	KLA2730-1	31140	37 3/16	47
4000	4000/3000W	KLA2040-1	31112	KLA2040-3	31122	KLA2440-1	31132	KLA2740-1	31142	47 3/16	57
5000	5000/3750W	KLA2050-1	31114	KLA2050-3	31124	KLA2450-1	31134	KLA2750-1	31144	57 3/16	67
6000	6000/4500W	KLA2060-1	31116	KLA2060-3	31126	KLA2460-1	31136	KLA2760-1	31146	65 3/16	79

Ordering Information Low density models (750W/ft)

WATTS	208V (1 ph)	UPC	208V (3 ph)	UPC	240V	UPC	277V	UPC	LENGTH	WT. (lbs.)
1500	KLA2015-1-690	31148	KLA2015-3-690	31156	KLA2415-1-690	31164	KLA2715-1-690	31172	27 3/16	37
2250	KLA2022-1-944	31150	KLA2022-3-944	31158	KLA2422-1-944	31166	KLA2722-1-944	31174	37 3/16	47
3000	KLA2030-1-1198	31152	KLA2030-3-1198	31160	KLA2430-1-1198	31168	KLA2730-1-1198	31176	47 3/16	57
4500	KLA2045-1-1655	31154	KLA2045-3-1655	31162	KLA2445-1-1655	31170	KLA2745-1-1655	31178	65 3/16	79

Engineering Specifications

Contractor shall supply and install KLA Series electric heaters of the wattage and voltage as indicated on the plans.

Color: Standard: white, almond. Optional: metallic silver, bronze, metallic charcoal, aluminum, semi-gloss black. Custom colors available upon request.

Finish: Standard: epoxy/polyester powder paint.

Voltage: 208V, 240/208V, 277V, 347V, 600V, 1 or 3-phase.

Construction: 20-gauge steel cabinet. 16-gauge steel front cover. Extruded aluminum bar grilles prevent insertion of foreign objects. Front fresh air inlet; top warm air outlet or front (-FR). Clean back available (-BD). Linear high-limit temperature control with automatic reset.

Heating element: Three stainless steel tubular heating elements with aluminum fins. Floating heating elements on high-temperature bushings, eliminating expansion noises.

Watt density: Standard watt density. Low watt density.

Control: Built-in tamperproof thermostat available. Mechanical, electronic or pneumatic relays available. Note: Single-pole thermostat is for 1-phase model only. King highly recommends to use an electronic wall thermostat for greater comfort.

Installation: Not for residential use in the United States. Wall or floor mounted installation. Front outlet (-FR) models may be recessed. Mounting holes spaced on 2 in. (51 mm) intervals for ease of installation. Variety of accessories available for wall-to-wall installation. Pedestal kit or sub-base available.

Warranty: 1-year warranty against defects.

Application: Commercial building, hospital, daycare center.

Architectural Convection Cabinet Heater KLA Series

Options

ADD SUFFIX	DESCRIPTION
-BW	Bright White
-A	Almond Color
-AE	Metallic Silver
-BZ	Bronze
-CM	Metallic Charcoal)
-AL	Aluminum
-NL	Semi-Gloss Black
-FR	Front outlet models may be recessed
-BD	Clean back

Dimensional Data

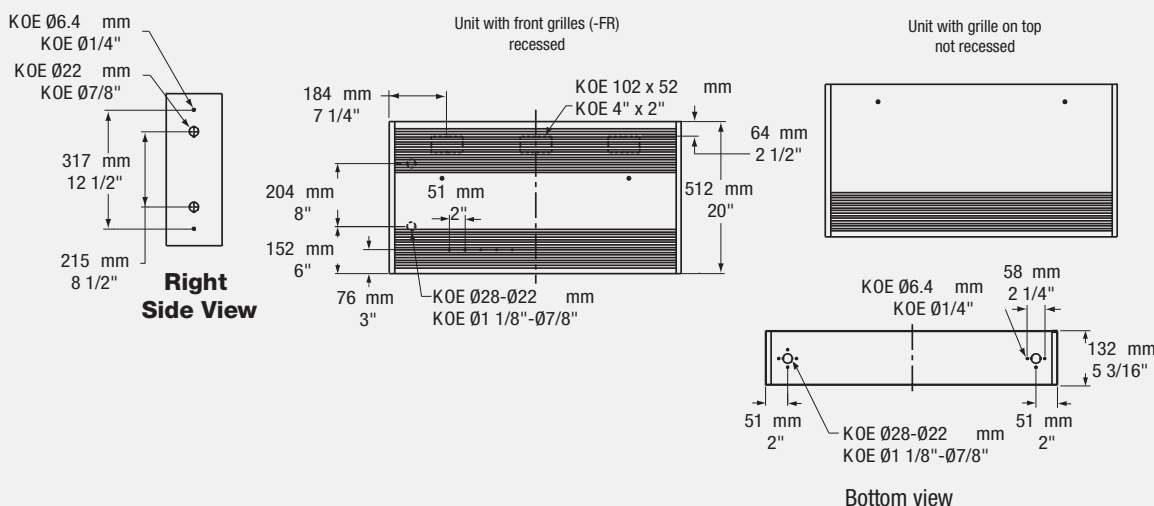

Control Options

MODEL	DESCRIPTION
KLA-T-AV	Single-pole tamperproof thermostat 30A, 250V max. - 15A, 600V max.
KLA-T2-AV	Double-pole tamperproof thermostat 30A, 250V max. - 15A, 600V max.
Product no-CTT	Single-pole relay, coil (240V), 25A, 240V - 12.5A, 600V
Product no-CTT2	Double-pole relay, coil (240V) 25A, 240V - 12.5A, 600V (Factory Installed Only)
KLA-R	Single-pole relay, coil (24V) 22A, 208V, 240V - 22A, 208V
KLA-R2	Double-pole relay, coil (24V) 25A, 240V - 12.5A, 600V
KLA-RT-208	Single-pole relay, coil (24V) Transformer (208V / 24V) - 4500W, 208V / 22A
KLA-RT-240	Single-pole relay, coil (24V) Transformer (240V / 24V) - 5200W, 240V / 22A
KLA-RT-277	Single-pole relay, coil (24V) Transformer (277V / 24A) - 5200W, 277V / 19A
Product no-TRF24	Transformer, 24V - 50VA
Product no-TRF24	Transformer, 240V - 50VA
Product no-PM	Factory installed pneumatic relay, 20A / 600V max.
KLA-CTR	Control box (width: 12")
Product no-DIS40	Factory installed disconnect switch 600V, three-pole, 40A

Accessories

MODEL	DESCRIPTION	DIMENSIONS (in)
KLA-CI	Corner (interior and exterior)	
KLA-PEC	Pedestal kit (2)	3 (height)
KLA-S0-27	Sub-base	27 3/16
KLA-S0-37	Sub-base	37 3/16
KLA-S0-47	Sub-base	47 3/16
KLA-S0-57	Sub-base	57 3/16
KLA-S0-65	Sub-base	65 3/16
KLA-CR-27	Recess trim kit	27 3/16
KLA-CR-37	Recess trim kit	37 3/16
KLA-CR-47	Recess trim kit	47 3/16
KLA-CR-57	Recess trim kit	57 3/16
KLA-CR-65	Recess trim kit	65 3/16
KLA-SV-27	Empty cabinet	27 3/16
KLA-SV-37	Empty cabinet	37 3/16
KLA-SV-47	Empty cabinet	47 3/16
KLA-SV-57	Empty cabinet	57 3/16
KLA-SV-65	Empty cabinet	65 3/16
Product no-BD	Factory installed clean back	
Product no-FR	Factory installed front warm air outlet	

*** Filler sections can be cut on workplace. Includes ends and wall supports.

Architectural Convection Cabinet Heater KLI Series



Model Code:

KLI	20	15	-3	-690
A	B	C	D	E
A: Series				
B: Volts (12=120, 20=208, 24=240, 27=270)				
C: Watts (15=1500)				
D: Phase (1 or 3)				
E: Length in mm (-690=690mm)				

- 3 steel tubular heating elements with aluminum fins
- Front fresh air inlet; top warm air outlet
- Standard Watt density of 1000W/ft. (3280W/m)
- Low Watt density of 750W/ft. (2460W/m)
- Linear high-limit temperature control with automatic reset
- Standard color: bright white (optional almond color available)
- 20 Gauge Steel Cabinet
- Available in 120, 208, 240, 277 or 600 Volts, 1 Or 3 phase
- 1-year warranty against defects



The KLI Series Cabinet Heater

The KLI series units offer all of the advantages of the KLA convector heater with the added characteristic of a sloped top which prevents objects from being placed on them. These natural convection heaters are well suited for applications requiring a power rating of 6000W without fan noise. Several options are also available for wall-to-wall installation. Perfect for hospitals or daycares.

NOT APPROVED FOR RESIDENTIAL USE.

Ordering Information Standard models (1000W/ft)

WATTS	240V/208V	208V (1 ph)	UPC	208V (3 ph)	UPC	240V/208V	UPC	277V	UPC	LENGTH	WT. (lbs.)
2000	2000/1500W	KLI2020-1	31180	KLI2020-3	31190	KLI2420-1	31200	KLI2720-1	31210	27 3/16	37
3000	3000/2250W	KLI2030-1	31182	KLI2030-3	31192	KLI2430-1	31202	KLI2730-1	31212	37 3/16	47
4000	4000/3000W	KLI2040-1	31184	KLI2040-3	31194	KLI2440-1	31204	KLI2740-1	31214	47 3/16	57
5000	5000/3750W	KLI2050-1	31186	KLI2050-3	31196	KLI2450-1	31206	KLI2750-1	31216	57 3/16	67
6000	6000/4500W	KLI2060-1	31188	KLI2060-3	31198	KLI2460-1	31208	KLI2760-1	31218	65 3/16	79

Ordering Information Low density models (750W/ft)

WATTS	208V (1 ph)	UPC	208V (3 ph)	UPC	240V	UPC	277V	UPC	LENGTH	WT. (lbs.)
1500	KLI2015-1-690	31220	KLI2015-3-690	31228	KLI2415-1-690	31236	KLI2715-1-690	31244	27 3/16	37
2250	KLI2022-1-944	31222	KLI2022-3-944	31230	KLI2422-1-944	31238	KLI2722-1-944	31246	37 3/16	47
3000	KLI2030-1-1198	31224	KLI2030-3-1198	31232	KLI2430-1-1198	31240	KLI2730-1-1198	31248	47 3/16	57
4500	KLI2045-1-1655	31226	KLI2045-3-1655	31234	KLI2445-1-1655	31242	KLI2745-1-1655	31250	65 3/16	79

Engineering Specifications

Contractor shall supply and install KLI Series electric heaters of the wattage and voltage as indicated on the plans.

Color: Standard: white, almond. Optional: metallic silver, bronze, metallic charcoal, aluminum, semi-gloss black. Custom colors available upon request.

Finish: Standard: epoxy/polyester powder paint.

Voltage: 208V, 240/208V, 277V, 347V, 600V, 1 or 3-phase.

Construction: 20-gauge steel cabinet. 16-gauge steel front cover. Extruded aluminum bar grilles prevent insertion of foreign objects. Front fresh air inlet; top warm air outlet. Clean back available (-BD). Linear high-limit temperature control with automatic reset.

Heating element: Three stainless steel tubular heating elements with aluminum fins. Floating elements on high-temperature nylon bushings eliminating expansion noises.

Watt density: Standard watt density. Low watt density.

Control: Built-in tamperproof thermostat available. Mechanical, electronic or pneumatic relays available. Note: Single-pole thermostat is for 1-phase model only. King highly recommends to use an electronic wall thermostat for greater comfort.

Installation: Not for residential use in the United States. Wall or floor mounted installation. Mounting holes spaced on 2 in. (51 mm) intervals for ease of installation. Variety of accessories available for wall-to-wall installation. Pedestal kit or sub-base available.

Warranty: 1-year warranty against defects.

Application: Commercial building, hospital, daycare center.

Architectural Convection Cabinet Heater KLI Series

Options

ADD SUFFIX	DESCRIPTION
-BW	Bright White
-A	Almond Color
-AE	Metallic Silver
-BZ	Bronze
-CM	Metallic Charcoal
-AL	Aluminum
-NL	Semi-Gloss Black
-BD	Clean back

Dimensional Data

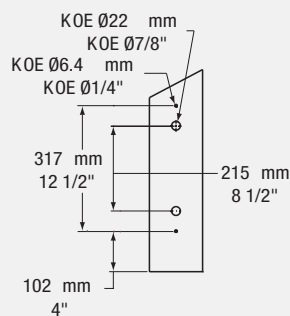

Right side view

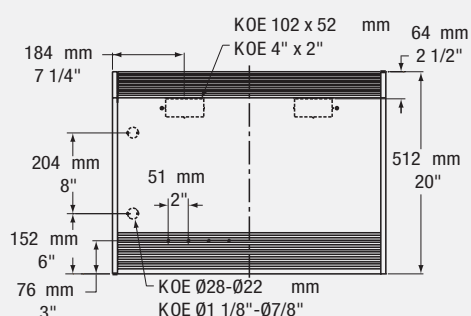

Front view

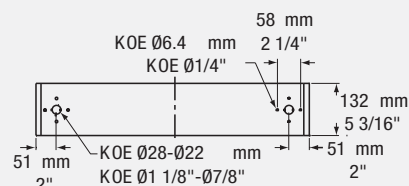

Bottom view

Control Options

MODEL	DESCRIPTION
KLI-T-AV	Single-pole tamperproof thermostat 30A, 250V max. - 15A, 600V max.
KLI-T2-AV	Double-pole tamperproof thermostat 30A, 250V max. - 15A, 600V max.
Product no-CTT	Single-pole relay, coil (240V), 25A, 240V - 12.5A, 600V (Factory Installed Only)
Product no-CTT2	Double-pole relay, coil (240V) 25A, 240V - 12.5A, 600V (Factory Installed Only)
KLI-R	Single-pole relay, coil (24V) 22A, 208V, 240V - 22A, 208V
KLI-R2	Double-pole relay, coil (24V) 25A, 240V - 12.5A, 600V
KLI-RT-208	Single-pole relay, coil (24V) Transformer (208V / 24V) - 4500W, 208V / 22A
KLI-RT-240	Single-pole relay, coil (24V) Transformer (240V / 24V) - 5200W, 240V / 22A
KLI-RT-277	Single-pole relay, coil (24V) Transformer (277V / 24A) - 5200W, 277V / 19A
Product no-TRF24	Transformer, 24V - 50VA
Product no-TRF240	Transformer, 240V - 50VA
Product no-PM	Factory installed pneumatic relay, 20A / 600V max.
KLI-CTR	Control box (width: 12")
Product no-DIS40	Factory installed disconnect switch 600V, three-pole, 40A

Accessories

MODEL	DESCRIPTION	DIMENSIONS (in)
KLI-CI	Corner (interior and exterior)	
KLI-PEC	Pedestal kit (2)	3 (height)
KLI-SO-27	Sub-base	27 3/16
KLI-SO-37	Sub-base	37 3/16
KLI-SO-47	Sub-base	47 3/16
KLI-SO-57	Sub-base	57 3/16
KLI-SO-65	Sub-base	65 3/16
KLI-SV-27	Empty cabinet	27 3/16
KLI-SV-37	Empty cabinet	37 3/16
KLI-SV-47	Empty cabinet	47 3/16
KLI-SV-57	Empty cabinet	57 3/16
KLI-SV-65	Empty cabinet	65 3/16
Product no-BD	Factory installed clean back	

*** Filler sections can be cut on workplace. Includes ends and wall supports.

Draft Barriers SB Series



Model Code:

SB	F	-ST	2	24	03
A	B	C	D	E	F

- A: Series
- B: Optional front intake
- C: -ST (Slope Top)
- D: Length
- E: Volts: 12=120V 20=208V
24=240V 27=277V
- F: Watts (200 - 2500)



- Full length thermal limit switch
- 14 gauge front and back
- Two piece all aluminum
- Convection heat
- Silent running
- Extended backs and fronts available
- 4" junction-boxes at each end
- 3/4" EMT raceway standard
- 3" D x 5" H cabinet size
- Available in gray, almond, bronze, white, & black
- Multiple heater sections on common back
- Custom cabinet lengths, 2-12 feet in 1/16" increments
- SBST approved for residential use
- 1/2" and 3/4" knockouts
- 1-year limited warranty

The SB Series Draft Barrier

Convection heat becomes an architectural finishing touch in the sleek appearance and continuous look of this heater.

An anodized aluminum finish is available (purchasing requirements may apply) with standard colors including white, gray, black, tan and bronze. Controls can be mounted conveniently in either end of the heater. Feed-through wiring is provided by a built-in wire-way running the entire length of the heater. End caps are required on standalone installation. Residential version requires a slope top. If you need a heater suitable for architectural, commercial and/or industrial use, this is it.

Dimensional Data

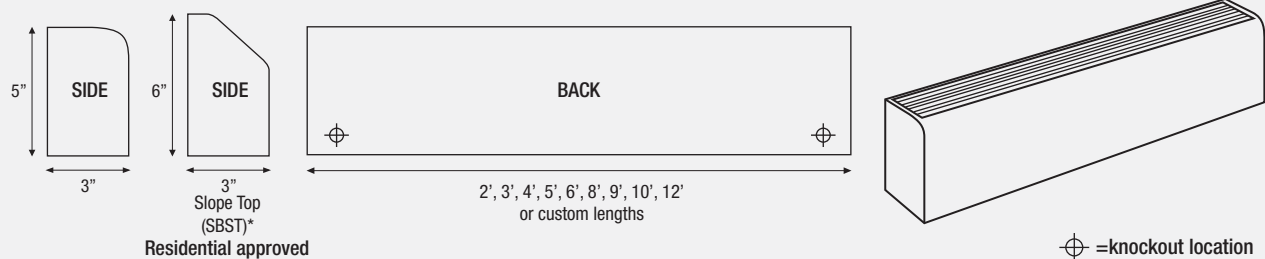

Engineering Specifications

- Model SB Architectural Draft Barriers shall be 5" H and 3" D. The front cover shall be 14 gauge extruded aluminum construction suitable for architectural, commercial and industrial use with 1/4" pencil-proof intake and discharge grilles. The one-piece cover shall be extruded for maximum strength and shall be available in lengths up to 12 feet.
- The cover shall be linear mount to the 14 gauge heater back with no visible fasteners. The 14 gauge heater back shall be suitable for mullion-to-mullion mounting.
- Standard painted finishes or optional anodizing shall be provided as specified by the architect. Color matching to architect's specifications are available as optional finishes.
- Heat sections from 2 - 10 feet are available. All heaters shall contain 3/4" EMT built-in raceway with factory wiring to provide field wiring from either end when optional controls are not included.
- 1/2" and 3/4" knockouts shall be provided in the side and rear of the heater junction-box to permit end-to-end wiring.
- All blank sections shall be fully enclosed to allow branch circuit wiring. All heaters shall contain a full length thermal overload protector with automatic reset. Wattages shall be available from 100 to 250 Watts per foot. Heating elements shall be tubular stainless steel or aluminum tubing with aluminum fins mechanically bonded to ensure efficient heat transfer.
- Element fin temperature shall not exceed 350°F to ensure long element life. Elements shall be center anchored and free-floating in nylon bushings at each end.
- Control sections are 6" or 12" for pneumatic relay, transformer relay, fused disconnect or duplex receptacle. Optional built-in heater controls shall include thermostats (single and double pole) and disconnect switches.
- Built-in controls shall be tamper-proof and shall be adjustable with a blade screwdriver through the discharge louver.
- All heaters are Underwriters Laboratories listed
- Tested under UL **Safety Standard UL#1042**

Draft Barriers SB Series

Ordering Information

*Also available in 120V, 208V, and 277 Volts. Available in 100 to 250 W/ft. Consult factory for model#

STANDARD MODEL	UPC	FRONT INTAKE MODEL	UPC	VOLTS*	WATTS	LENGTH	NOMINAL WATTS / FT.
SB22404	14428	SBF22404	14464	240	400	2'	200
SB22405	14430	SBF22405	14466	240	500	2'	250
SB32406	14432	SBF32406	14468	240	600	3'	200
SB32407	14434	SBF32407	14470	240	750	3'	250
SB42408	14436	SBF42408	14472	240	800	4'	200
SB42410	14438	SBF42410	14474	240	1000	4'	250
SB52410	14440	SBF52410	14476	240	1000	5'	200
SB52412	14442	SBF52412	14478	240	1250	5'	250
SB62412	14444	SBF62412	14480	240	1200	6'	200
SB62415	14446	SBF62415	14482	240	1500	6'	250
SB72414	14448	SBF72414	14484	240	1400	7'	200
SB72417	14450	SBF72417	14486	240	1750	7'	250
SB82416	14452	SBF82416	14488	240	1600	8'	200
SB82420	14454	SBF82420	14490	240	2000	8'	250
SB92420	14456	SBF92420	14492	240	2000	9'	200
SB92422	14458	SBF92422	14494	240	2250	9'	250
SB102420	14460	SBF102420	11496	240	2000	10'	200
SB102425	14462	SBF102425	14498	240	2500	10'	250

Accessories

MODEL	DESCRIPTION
SB-100BS	1FT. Blank Section
SB-200BS	2FT. Blank Section
SB-300BS	3FT. Blank Section
SB-400BS	4FT. Blank Section
SB-500BS	5FT. Blank Section
SB-600BS	6FT. Blank Section
SB-700BS	7FT. Blank Section
SB-800BS	8FT. Blank Section
SB-900BS	9FT. Blank Section
SB1000BS	10FT. Blank Section

Options

MODEL	DESCRIPTION
SB-IC	Inside Corner
SB-OC	Outside Corner
SB-EC	REQUIRED End Cap (Specify right or left) 1/2"
SB-SP	Splice Plate
SB-WT	Wall Trim
SB-MESH	1/4" Wire mesh under discharge grille
SB-PD-FM	Pedestals (field mounting)

Control Sections

MODEL	DESCRIPTION
SBCS-TS	Thermostat Section - SPST, 20 Amp, 277 Volts
SBCS-TSDS	Thermostat Disconnect Switch Section, 20 Amp
SBCS-TSR	Thermostat Relay Switch, 20 Amp
SBCS-TSDSR	Thermostat Disconnect Switch, Relay Section, 20 Amp
SBCS-DS	Disconnect Switch, Section, 20 Amp
SBCS-R	Relay Section - SPST, 20 Amp, 277 Volt
SBCS-RDS	Relay, Disconnect Switch Section, 20 Amp
SBCS-TR	Xformer Relay Section - SPST, 25 Amp, 277 V, 24V Control
SBCS-TRDS	Transformer Relay, Disconnect Switch Section, 20 Amp
SBCS-PE	PE Relay, SPST, 20 Amp
SBCS-DS-FUSED	Disconnect Switch, with 20 Amp fuse and fuse block

Integral Controls

MODEL	DESCRIPTION
ITS	Integral Stat 25 Amp, SPST-120-277 Volts - STD-LF or RT
ITD	Integral Stat 20 Amp, DPST-208-240 Volts - STD-LF or RT
IDS	Integral Disconnect Switch 20 Amp, 120-277 V - STD-RT side

Corners, Fillers, Blank Sections & End Caps

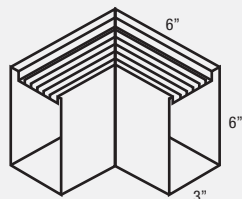

Inside Corner

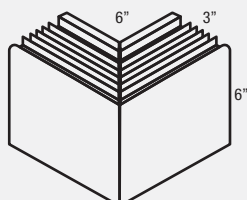

Outside Corner

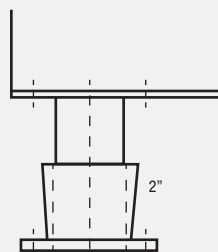

Cast Pedestal

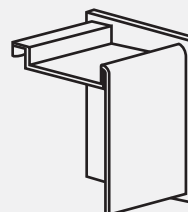

Left End Cap

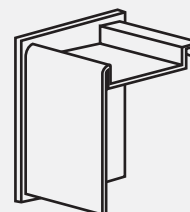

Right End Cap

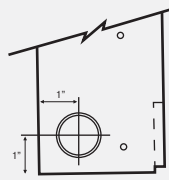

Side View
Pedestal Unit Only

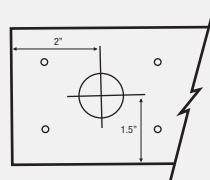

Bottom View
Pedestal Unit Only

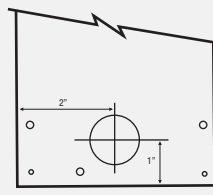

Back View
Pedestal Unit Only

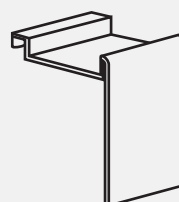

Splice Plate

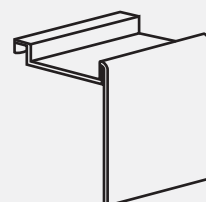

Wall Trim

Draft Barriers LB Series



Model Code:

LB	F	2	24	03
A	B	C	D	E

A: Series
 B: Optional front intake
 C: Length
 D: Volts: 12=120V 20=208V
 24=240V 27=277V
 E: Watts (376 - 5000)



- Full length thermal limit switch
- 14 gauge front and back
- Two piece all aluminum
- Convection heat
- Quiet running
- Extended backs and fronts available
- 4" junction-boxes at each end
- ¾" EMT raceway standard
- 7" H x 5" D cabinet size
- Available in gray, almond, bronze, white, black & more
- Multiple heater sections on common back
- Custom cabinet lengths, 2-12 feet in 1/16" increments
- ½" and ¾" knockouts
- 1-year limited warranty

The LB Series Draft Barrier

This draft heater is used for tall glass walls or complete heating of large commercial spaces. The sleek lines complement any commercial building. Feed-through wire-ways help provide continuous wall-to-wall warmth. Controls can be conveniently mounted in either end of the heater or in a separate section. Heated sections can be anywhere within the case. End caps are required on stand alone installation. Custom paint colors are available. Optional anodized finishes can match window finishes. Suitable for industrial and commercial uses.

Dimensional Data

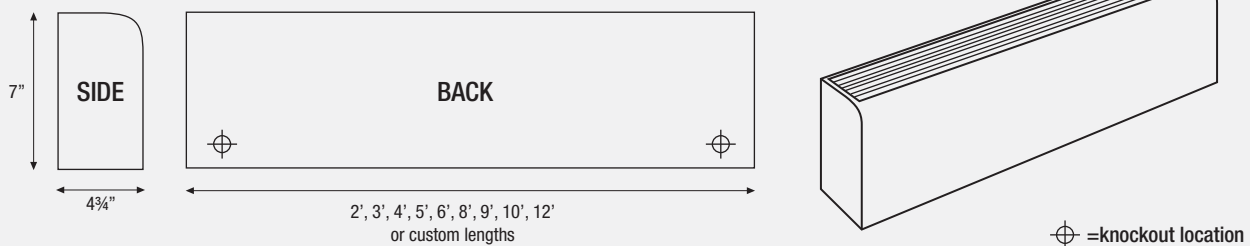

*Smooth back available when pedestal mounted and back can be seen.

Engineering Specifications

- Model LB Architectural Draft Barriers shall be 7" H and 5" D. The front cover shall be 12 gauge extruded aluminum construction suitable for architectural, commercial and industrial use with ¼" pencil-proof intake and discharge grilles. The one-piece cover shall be extruded for maximum strength and available in lengths up to 12 feet.
- The cover shall be linear mount to the 12 gauge heater back with no visible fasteners. The 12 gauge heater back shall be suitable for mullion-to-mullion mounting.
- Standard painted finishes or optional anodizing shall be provided as specified by the architect. Color matching to architect's specifications are available as optional finishes.
- Heat sections from 2 -10 feet are available. All heaters shall contain ¾" EMT built-in raceway with factory wiring to provide field wiring from either end when optional controls are not included.
- ½" and ¾" knockouts shall be provided in the side and rear of the heater junction-box to permit end-to-end wiring. All blank sections shall be fully enclosed to allow branch circuit wiring.
- All heaters shall contain a full length thermal overheat protector with automatic reset. Wattages shall be available from 100 to 500 Watts per foot. Heating elements shall be tubular stainless steel or aluminum tubing with aluminum fins mechanically bonded to ensure efficient heat transfer.
- Element fin temperature shall not exceed 350°F to ensure long element life. Elements shall be center anchored and free-floating in nylon bushings at each end.
- Control sections are 6" or 12" for pneumatic relay, transformer relay, fused disconnect or duplex receptacle. Optional built-in heater controls shall include thermostats (single and double pole) and disconnect switches.
- Built-in controls shall be tamper-proof and shall be adjustable with a blade screwdriver through the discharge louver.
- All heaters are Underwriters Laboratories listed.
- Tested under UL Safety Standard UL#1042.

Draft Barriers LB Series

Ordering Information

*Also available in 120V, 208V, and 277 Volts. Consult factory for model#

STANDARD MODEL	UPC	FRONT INTAKE MODEL	UPC	VOLTS*	WATTS	LENGTH	NOMINAL WATTS / FT.
LB22403	14300	LBF22403	14364	240	376	2'	188
LB22405	14302	LBF22405	14366	240	500	2'	250
LB22407	14304	LBF22407	14368	240	750	2'	350
LB22410	14306	LBF22410	14370	240	1000	2'	500
LB32405	14308	LBF32405	14372	240	564	3'	188
LB32407	14310	LBF32407	14374	240	750	3'	250
LB32411	14312	LBF32411	14376	240	1125	3'	350
LB32415	14314	LBF32415	14378	240	1500	3'	500
LB42407	14316	LBF42407	14380	240	750	4'	188
LB42410	14318	LBF42410	14382	240	1000	4'	250
LB42415	14320	LBF42415	14384	240	1500	4'	350
LB42420	14322	LBF42420	14386	240	2000	4'	500
LB52409	14324	LBF52409	14388	240	940	5'	188
LB52412	14326	LBF52412	14390	240	1250	5'	250
LB52418	14328	LBF52418	14392	240	1875	5'	350
LB52425	14330	LBF52425	14394	240	2500	5'	500
LB62411	14332	LBF62411	14396	240	1125	6'	188
LB62415	14334	LBF62415	14398	240	1500	6'	250
LB62422	14336	LBF62422	14400	240	2250	6'	350
LB62430	14338	LBF62430	14402	240	3000	6'	500
LB82415	14340	LBF82415	14404	240	1500	8'	188
LB82420	14342	LBF82420	14406	240	2000	8'	250
LB82430	14344	LBF82430	14408	240	3000	8'	350
LB82440	14346	LBF82440	14410	240	4000	8'	500
LB92416	14348	LBF92416	14412	240	1692	9'	188
LB92422	14350	LBF92422	14414	240	2250	9'	250
LB92433	14352	LBF92433	14416	240	3375	9'	350
LB92455	14354	LBF92455	14418	240	4500	9'	500
LB102418	14356	LBF102418	14420	240	1875	10'	188
LB102425	14358	LBF102425	14422	240	2500	10'	250
LB102437	14360	LBF102437	14424	240	3750	10'	350
LB102450	14362	LBF102450	14426	240	5000	10'	500

*Do not install less than 1-1/2" above floor on bottom air intake style.
Available in 100 to 500 W/ft. Consult factory for model#

Accessories

MODEL	DESCRIPTION
LB-100BS	1FT. Blank Section
LB-200BS	2FT. Blank Section
LB-300BS	3FT. Blank Section
LB-400BS	4FT. Blank Section
LB-500BS	5FT. Blank Section
LB-600BS	6FT. Blank Section
LB-700BS	7FT. Blank Section
LB-800BS	8FT. Blank Section
LB-900BS	9FT. Blank Section
LB1000BS	10FT. Blank Section

Options

MODEL	DESCRIPTION
LB-IC	Inside Corner
LB-OC	Outside Corner
LB-EC	REQUIRED End Cap (Specify right or left) 1/2"
LB-SP	Splice Plate
LB-WT	Wall Trim
LB-MESH	1/4" Wire mesh under discharge grill
LB-PD-FM	Pedestals (field mounting)

Control Sections

MODEL	DESCRIPTION
LBCS-R	Relay Section - SPST, 20 Amp, 277 Volt
LBCS-RDS	Relay, Disconnect Switch Section, 20 Amp
LBCS-TR	Xformer Relay Section - SPST, 25 Amp, 277 V, 24V Control
LBCS-TRDS	Transformer Relay, Disconnect Switch Section, 20 Amp
LBCS-PE	PE Relay, SPST, 20 Amp
LBCS-DS-FUSED	Disconnect Switch, with 20 Amp fuse and fuse block

Integral Controls

MODEL	DESCRIPTION
ITS	Integral Stat 25 Amp, SPST-120-277 Volts - STD-LF or RT
ITD	Integral Stat 20 Amp, DPST-208-240 Volts - STD-LF or RT
IDS	Integral Disconnect Switch 20 Amp, 120-277 V - STD-RT side
LBCS-TS	Thermostat Section - SPST, 20 Amp, 277 Volts
LBCS-TSDS	Thermostat Disconnect Switch Section, 20 Amp
LBCS-TSR	Thermostat Relay Switch, 20 Amp
LBCS-TSDSR	Thermostat Disconnect Switch, Relay Section, 20 Amp
LBCS-DS	Disconnect Switch, Section, 20 Amp

Draft Barriers LB Series

Corners, Fillers, Blank Sections & End Caps

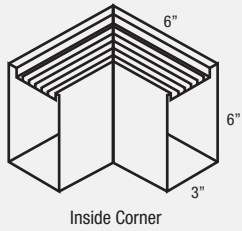

Inside Corner

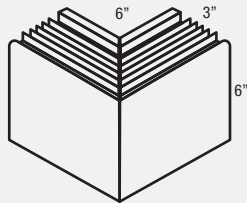

Outside Corner

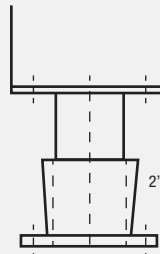

Cast Pedestal

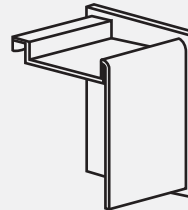

Left End Cap

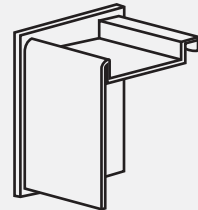

Right End Cap

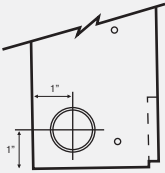

Side View
Pedestal Unit Only

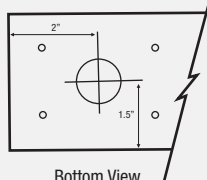

Bottom View
Pedestal Unit Only

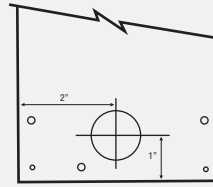

Back View
Pedestal Unit Only

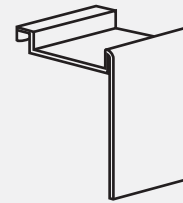

Splice Plate

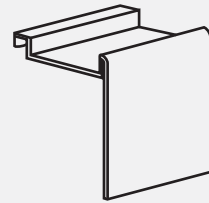

Wall Trim

LB EXPLODED VIEW

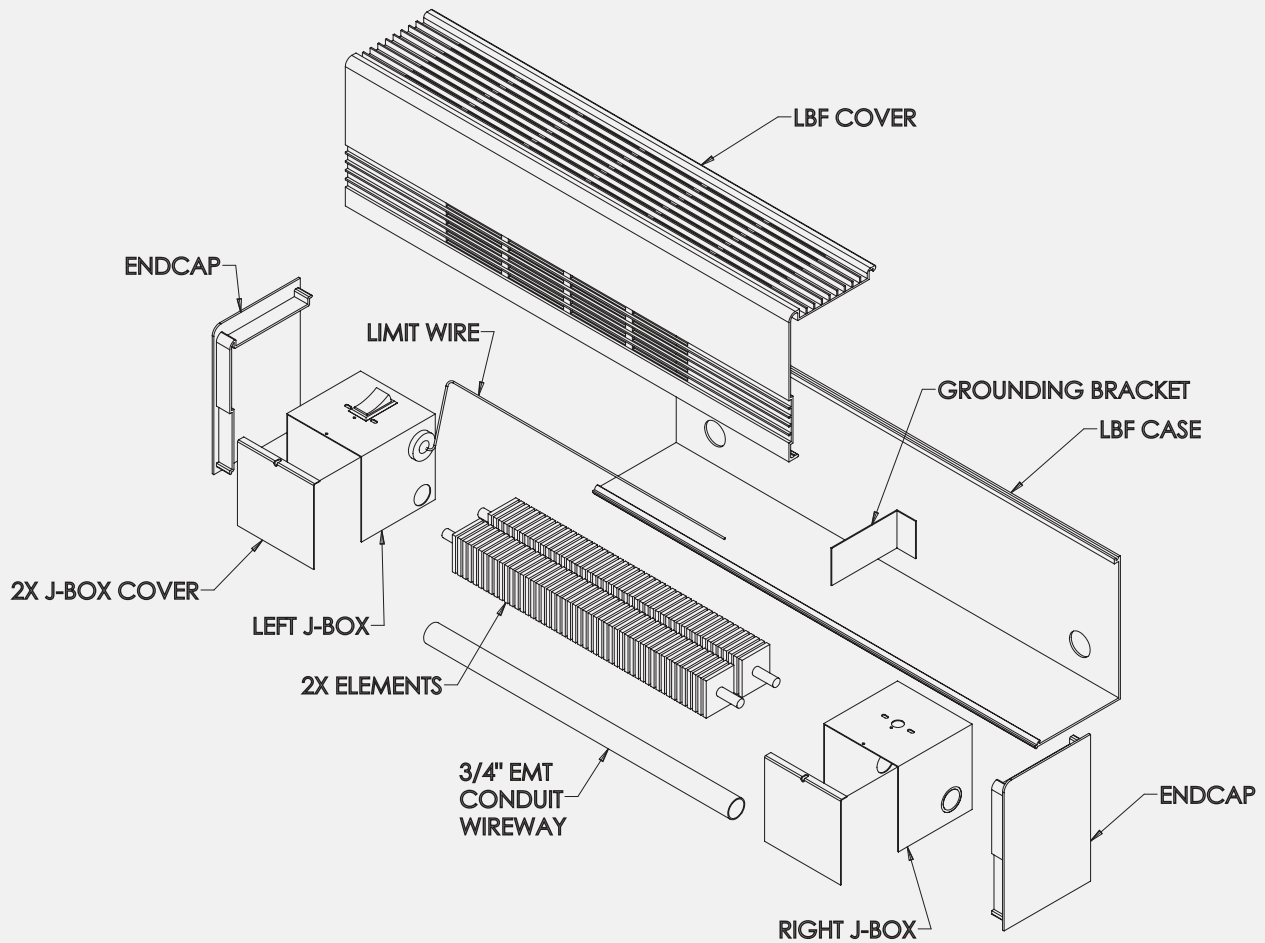

Architectural Draft Barrier KDBA Series



Model Code:

KDBA	12	040	-731
A	B	C	D

- A: Series
- B: Volts (12=120, 24=240, 27=270)
- C: Watts (040=400)
- D: Length in mm (-731=731mm)

- Steel tubular heating elements with aluminum fins
- Front fresh air inlet or bottom (-BAI); top warm air outlet
- Standard watt density of 275W/ft. (900W/m)
- Low watt density of 200W/ft. (650W/m)
- Linear high-limit temperature control with automatic reset
- Standard color: bright white epoxy/polyester powder paint
- 18 gauge steel cabinet
- Available in 120, 208, 240, 277, 347 or 600 volts, 1 phase
- 1-year warranty against defects



The KDBA Series Draft Barrier

A compact, economical draft barrier. Made from steel the KDBA draft barrier is an economical alternative to the aluminum model, yet offering comparable performance. With its rectangular shape, the KDBA is perfect for wall-to-wall installations.

Ordering Information Standard models (275W/ft)

WATTS	240V/208V	208V (1 ph)	UPC	208V (3 ph)	UPC	240V/208V	UPC	277V	UPC	LENGTH	WT. (lbs.)
500	500/375	KDBA12050	31552	KDBA20050	31562	KDBA24050	31580	KDBA27050	31598	28 13/16	10.5
750	750/563	KDBA12075	31554	KDBA20075	31564	KDBA24075	31582	KDBA27075	31600	38 13/16	12.7
1000	1000/750	KDBA12100	31556	KDBA20100	31566	KDBA24100	31584	KDBA27100	31602	49 1/16	14.9
1250	1250/938	KDBA12125	31558	KDBA20125	31568	KDBA24125	31586	KDBA27125	31604	58 9/16	17
1500	1500/1125	KDBA12150	31560	KDBA20150	31570	KDBA24150	31588	KDBA27150	31606	67 1/4	18.8
1750	1750/1313			KDBA20175	31572	KDBA24175	31590	KDBA27175	31608	76 9/16	20.8
2000	2000/1500			KDBA20200	31574	KDBA24200	31592	KDBA27200	31610	85 3/8	22.7
2250	2250/1688			KDBA20225	31576	KDBA24225	31594	KDBA27225	31612	94 3/16	24.6
2500	2500/1875			KDBA20250	31578	KDBA24250	31596	KDBA27250	31314	103 3/8	26.6

Ordering Information Low density models (200W/ft)

WATTS	240V/208V	120V	UPC	208V	UPC	240V/208V	UPC	277V	UPC	LENGTH	WT. (lbs.)
400	400/225	KDBA12040-731	31616	KDBA20040-731	31628	KDBA24040-731	31646	KDBA27040-731	31664	28 13/16	10.5
600	600/375	KDBA12060-985	31618	KDBA20060-985	31630	KDBA24060-985	31648	KDBA27060-985	31666	38 13/16	12.7
800	800/563	KDBA12080-1246	31620	KDBA20080-1246	31632	KDBA24080-1246	31650	KDBA27080-1246	31668	49 1/16	14.9
1000	1000/750	KDBA12100-1487	31622	KDBA20100-1487	31634	KDBA24100-1487	31652	KDBA27100-1487	31670	58 9/16	17
1200	1200/938	KDBA12120-1708	31624	KDBA20120-1708	31636	KDBA24120-1708	31654	KDBA27120-1708	31672	67 1/4	18.8
1600	1600/1125	KDBA12160-2168	31626	KDBA20160-2168	31638	KDBA24160-2168	31656	KDBA27160-2168	31674	85 3/8	22.7
1800	1800/1313			KDBA20180-2393	31640	KDBA24180-2393	31658	KDBA27180-2393	31676	94 3/16	24.6
2000	2000/1500			KDBA20200-2625	31642	KDBA24200-2625	31660	KDBA27200-2625	31678	103 3/8	26.6
2250	2250/1688			KDBA20225-2625	31644	KDBA24225-2625	31662	KDBA27225-2625	31680	103 3/8	26.6

Specifications

Contractor shall supply and install KDBA Series electric heaters of the wattage and voltage as indicated on the plans.

Color: Standard: white, almond. Optional: metallic silver, bronze, metallic charcoal, aluminum, semi-gloss black. Custom colors available.

Finish: Standard: epoxy/polyester powder paint. Optional: steel plated.

Voltage: 120V, 208V, 240V/208V, 277V, 347V, 600V, 50/60 Hz, 1-phase.

Construction: 16-gauge steel front cover. 18-gauge satin coat steel cabinet.

Screw assembly for added strength. Full length built-in wireway. Front fresh air inlet or bottom (-BAI); top warm air outlet. Clean back available (-BD). Linear high-limit temperature control with automatic reset. High altitude version available (-HA). End caps included.

Heating Element: Stainless steel tubular heating element with aluminum fins.

Floating heating element on high-temperature nylon bushings eliminating expansion noises.

Watt Density: Standard watt density. Low watt density.

Control: Built-in thermostat available with a control knob or tamperproof. Mechanical, electronic or pneumatic relays available (installed on the right end only). King highly recommends the use of an electronic wall thermostat for greater comfort.

Installation: Heater must be installed at least 2 in. from finished floor (for -BAI option). Mounting holes spaced on 4 in. intervals for ease of installation. Wall or floor mounted installation. Variety of accessories available for wall-to-wall installation. Pedestal kit available.

Warranty: 1-year warranty against defects.

Application: Commercial building, office building, hospital, daycare center, private residence.

Architectural Draft Barrier KDBA Series

Options

ADD SUFFIX	DESCRIPTION
-BW	Bright White
-A	Almond Color
-AE	Metallic Silver
-BZ	Bronze
-CM	Metallic Charcoal
-AL	Aluminum
-NL	Semi-Gloss Black
-HA	High altitude version linear high-limit temperature control with automatic reset
-BAI	Bottom fresh air inlet

Dimensional Data

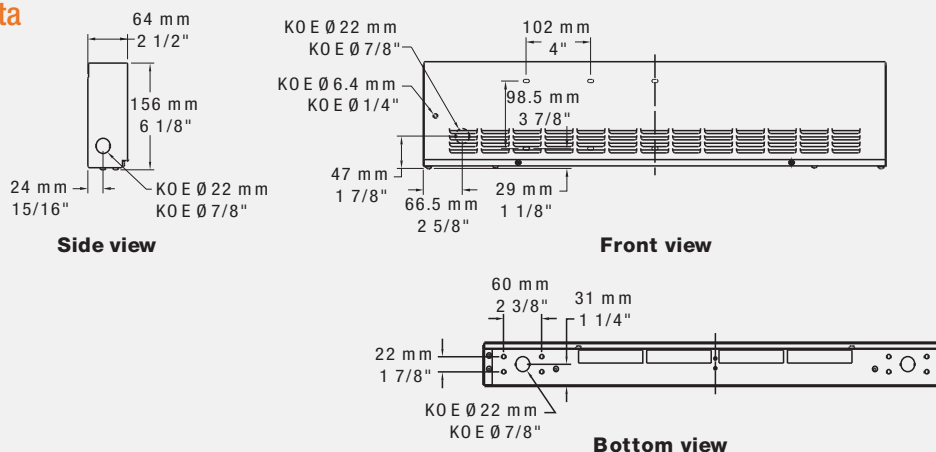

Control Options

MODEL	DESCRIPTION
KDBA-T-AV (1-3)	Single-pole tamperproof thermostat adjustable with a screwdriver
	120V, 208V, 240V/25A, 277V/10A
KDBA-T2-AV (1-2)	Double-pole tamperproof thermostat adjustable with a screwdriver
	120V, 208V, 240V/25A, 277V/10A
KDBA-T (1-3)	Single-pole thermostat with control knob
	120V, 208V, 240V/25A, 277V/10A
KDBA-T2 (1-2)	Double-pole thermostat with control knob
	120V, 208V, 240V/25A, 277V/10A
KDBA-RT-120	24V relay with transformer - 120V/22A
KDBA-RT-208	24V relay with transformer - 208V/22A
KDBA-RT-240	24V relay with transformer - 240V/22A
KDBA-RT-277	24V relay with transformer - 277V/19A
KDBA-R	24V relay without transformer
	120V, 208V, 240V/22A, 277V/19A
Product no-TRIAC	Factory installed 24V electronic relay 15A, 347V and less
Product no-TRIACT	Factory installed 24V electronic relay with transformer - 15A, 208V to 347V max.
Product no-PM	Factory installed pneumatic relay - 20A, 480V max.
Product no-DIS	Factory installed disconnect switch 20A, 277V max.

- 1) Setting range: 40°F to 100°F (5°C to 37°C)
- 2) "Off" position
- 3) Thermostat connect will remain open down to -31°F (-35°C) when set at its minimum

Accessories

MODEL	DESCRIPTION	DIMENSIONS (in)
KDBA-CI	Inside corner	4
KDBA-CE	Outside corner	4
KDBA-PE	Round pedestal kit (2)	3
KDBA-PEC	Square-shaped pedestal kit (2)	2
KDBA-JT	Splice plate	2
KDBA-JT-PE	Contour splice plate for BD option and/or heater with pedestals	2
Product no-HA	Factory installed linear high-limit temperature control for high altitude (6000 ft. to 8200 ft.)	
Product no-BD	Factory installed clean back	
KDBA-SV-XX	Empty cabinet with length XX mm	
Product no-BAI	Factory installed bottom fresh air inlet with smooth front panel	

Architectural Draft Barrier KDIA Series

Model Code:

KDIA	24	250
A	B	C

A: Series
 B: 12=120V 20=208V
 24=240/208V 27=277V
 C: Watts (50=500 - 250=2500)



- Steel tubular heating elements with aluminum fins
- Front fresh air inlet or bottom (-BAI); top warm air outlet
- Standard watt density of 275W/ft. (900W/m)
- Low watt density of 200W/ft. (650W/m)
- Linear high-limit temperature control with automatic reset
- Standard color: bright white epoxy/polyester powder paint
- 18 gauge steel cabinet
- Available in 120, 208, 240, 277, 347 or 600 volts, 1 phase
- 1-year warranty against defects

The KDIA Series Slope-Top Architectural Draft Barrier

The KDIA Series is an economical sloped top draft barrier. The KDIA draft barrier is specifically designed with a sloped top to eliminate use of the unit as a shelf or seat. Made from steel, the KDIA is an economical alternative to the aluminum sloped top model, yet offering comparable performance. This sloped top draft barrier takes up less space and is well suited for areas where space is limited.

Ordering Information - Standard Models (275W/FT)

WATTS	240V/208V	120V	UPC	208V	UPC	240V/208V	UPC	277V	UPC	LENGTH	WT. (lbs.)
500	500/375	KDIA12050	31682	KDIA20050	31692	KDIA24050	31710	KDIA27050	31728	28 13/16	11.6
750	750/563	KDIA12075	31684	KDIA20075	31694	KDIA24075	31712	KDIA27075	31730	38 13/16	15.1
1000	1000/750	KDIA12100	31686	KDIA20100	31696	KDIA24100	31714	KDIA27100	31732	49 1/16	18.7
1250	1250/938	KDIA12125	31688	KDIA20125	31698	KDIA24125	31716	KDIA27125	31734	58 9/16	22
1500	1500/1125	KDIA12150	31690	KDIA20150	31700	KDIA24150	31718	KDIA27150	31736	67 1/4	25
1750	1750/1313			KDIA20175	31702	KDIA24175	31720	KDIA27175	31738	76 9/16	28.3
2000	2000/1500			KDIA20200	31704	KDIA24200	31722	KDIA27200	31740	85 3/8	31.3
2250	2250/1688			KDIA20225	31706	KDIA24225	31724	KDIA27225	31742	94 3/16	34.4
2500	2500/1875			KDIA20250	31708	KDIA24250	31726	KDIA27250	31744	103 3/8	37.6

Ordering Information - Low Density (200W/FT)

WATTS	240V/208V	120V	UPC	208V	UPC	240V/208V	UPC	277V	UPC	LENGTH	WT. (lbs.)
400	400/225	KDIA12040-733	31746	KDIA20040-733	31758	KDIA24040-733	31776	KDIA27040-733	31794	28 7/8	11.6
600	600/375	KDIA12060-987	31748	KDIA20060-987	31760	KDIA24060-987	31778	KDIA27060-987	31796	38 7/8	15.1
800	800/563	KDIA12080-1248	31750	KDIA20080-1248	31762	KDIA24080-1248	31780	KDIA27080-1248	31798	49 1/8	18.7
1000	1000/750	KDIA12100-1489	31752	KDIA20100-1489	31764	KDIA24100-1489	31782	KDIA27100-1489	31800	58 5/8	22
1200	1200/938	KDIA12120-1710	31754	KDIA20120-1710	31766	KDIA24120-1710	31784	KDIA27120-1710	31802	67 5/16	25
1600	1600/1125	KDIA12160-2170	31756	KDIA20160-2170	31768	KDIA24160-2170	31786	KDIA27160-2170	31804	85 7/16	28.3
1800	1800/1313			KDIA20180-2395	31770	KDIA24180-2395	31788	KDIA27180-2395	31806	94 5/16	31.3
2000	2000/1500			KDIA20200-2627	31772	KDIA24200-2627	31790	KDIA27200-2627	31808	103 7/16	34.4
2250	2250/1688			KDIA20225-2627	31774	KDIA24225-2627	31792	KDIA27225-2627	31810	103 7/16	37.6

Options

ADD SUFFIX	DESCRIPTION
-BW	Bright White
-A	Almond Color
-AE	Metallic Silver
-BZ	Bronze
-CM	Metallic Charcoal
-AL	Aluminum
-NL	Semi-Gloss Black
-HA	High altitude version linear high-limit temperature control with automatic reset
-BAI	Bottom fresh air inlet

Architectural Draft Barrier KDIA Series

Dimensional Data

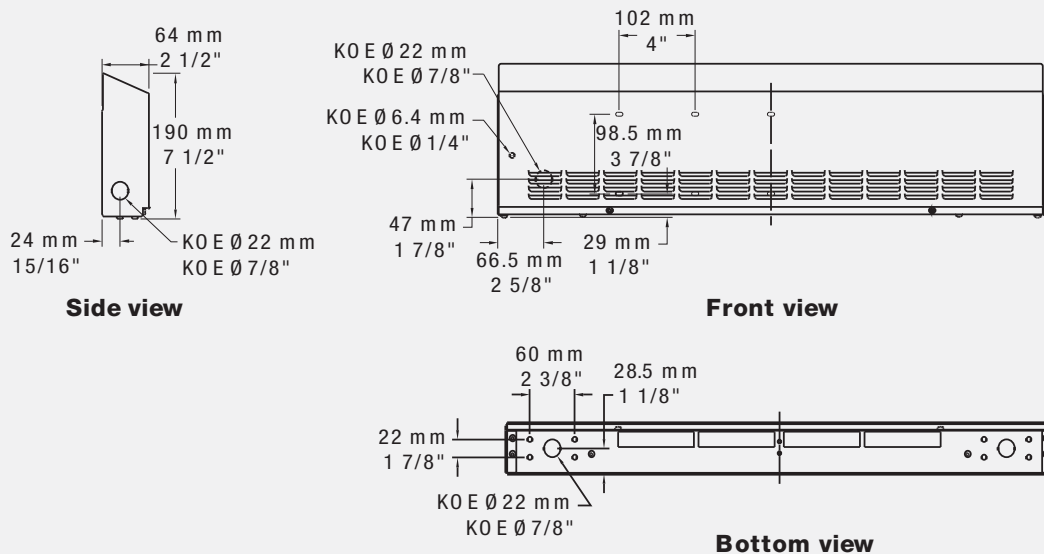

Control Options

MODEL	DESCRIPTION
KDIA-T-AV (1-3)	Single-pole tamperproof thermostat adjustable with a screwdriver 120V, 208V, 240V/25A, 277V/10A
KDIA-T2-AV (1-2)	Double-pole tamperproof thermostat adjustable with a screwdriver 120V, 208V, 240V/25A, 277V/10A
KDIA-T (1-3)	Single-pole thermostat with control knob 120V, 208V, 240V/25A, 277V/10A
KDIA-T2 (1-2)	Double-pole thermostat with control knob 120V, 208V, 240V/25A, 277V/10A
KDIA-RT-120	24V relay with transformer - 120V/22A
KDIA-RT-208	24V relay with transformer - 208V/22A
KDIA-RT-240	24V relay with transformer - 240V/22A
KDIA-RT-277	24V relay with transformer - 277V/19A
KDIA-R	24V relay without transformer 120V, 208V, 240V/22A, 277V/19A
Product no-TRIAC-347	Factory installed 24V electronic relay 15A, 347V and less
Product no-TRIAC-347T	Factory installed 24V electronic relay with transformer - 15A, 208V to 347V max.
Product no-PM	Factory installed pneumatic relay - 20A, 480V max.
Product no-DIS	Factory installed disconnect switch 20A, 277V max.

Accessories

MODEL	DESCRIPTION	DIMENSIONS (in)
KDIA-CI	Inside corner	4
KDIA-CE	Outside corner	4
KDIA-PE	Round pedestal kit (2)	3
KDIA-PEC	Square-shaped pedestal kit (2)	2
KDIA-JT	Splice plate	2
KDIA-JT-PE	Contour splice plate for BD option and/or heater with pedestals	2
Product no-HA	Factory installed linear high-limit temperature control for high altitude (6000 ft. to 8200 ft.)	
Product no-BD	Factory installed clean back	
KDIA-SV-XX	Empty cabinet with length XX mm	
Product no-BAL	Factory installed bottom fresh air inlet with smooth front panel	

Selecting The Proper Unit Heater

To obtain the best performance from King unit heaters use this chart for proper heater selection. To determine which type of unit is best note the ceiling height and room size. In addition to the air throw capabilities of each type of unit heater, wall and ceiling insulation must be considered when determining wattage requirements. The most common error of unit heater selection is installing a unit designed for low ceiling application on a high ceiling. In this application heat is unable to circulate properly to the floor – the result: unsatisfactory comfort or performance level. Following this guide allows correct unit heater selection for the determined space and environment. With correct selection and placement this King unit heater will provide years of high performance heating.

Application Tips

First, calculate heating loads in the conventional way using the N.E.M.A. handbook or ASHRAE guide. Next, determine quantity and size of heaters to be used. In instances where large groups of people are normally settled in the same location use a large number of smaller kW heaters (Example: people on a production line or skilled machine operations). By utilizing heaters in this manner one can best distribute uniform heat, prevent hot drafts, reduce potential noise levels and balance the electrical operating demand. When considering warehouse areas or storage rooms where heat distribution and constant temperatures are less important, use fewer heaters of higher capacity. To maintain uniform heat and reduce stratified air it is recommended that the total CFM of the units turn the air over approximately 3 times per hour.

Horizontal Mount

Smaller rooms can be heated by one unit heater. Where two walls are exposed heaters should be mounted as shown below. In larger rooms, units should be located so air streams wipe exposed walls without blowing at them. Units should be located so the airstream of one supports that of another thus setting up a circulatory air movement. (Distance between units to be approximately 1 times published air throw). Units should not be mounted horizontally in areas having ceiling heights in excess of 10 to 12 feet. *See Figure 1*

Vertical Mount

Units should be mounted vertically in high bay areas where they may not otherwise interfere with assorted material or handling equipment. Heaters should be situated to provide free air circulation. Size and selection of units should be based on recommended mounting height. Unit heaters are frequently used to combat cold air inrush when loading dock doors are opened. For such applications, one or more units should be arranged to blow warm air vertically in front of opening. *See Figure 2*

Dual Mounting

Where square footage is large and comfort essential, both horizontal and vertical installations may best serve your requirements. *See Figure 3*

Mounting Limitations

Unit heaters should not be used in potentially explosive atmospheres. The finish is not intended for direct salt spray exposure in marine applications or the highly corrosive atmospheres of swimming pools, chemical storage bins, etc. Please refer to the factory for explosion proof or marine application heater information. Do not install unit heaters above recommended maximum mounting height. See chart for height information. Obstructions must not block unit heater air inlet or discharge. To prevent possible injury heaters must be mounted at least 6 feet above the floor to prevent accidental contact with heating element or fan blade.

Selection

CEILING HEIGHT	UNDER 8 FEET	10 FEET	12 FEET	13 FEET AND OVER
250 Sq. Ft.	N/A	KBP	KBP	KFUH
1000 Sq. Ft.	KBP	KBP	KBP / KB	KFUH
2000 Sq.Ft.	KBP / KB	KBP / KB	KB / KFUH	KFUH
3000 Sq. Ft.	KB	KB	KFUH	KFUH
5000 Sq. Ft.	KB	KFUH	KFUH	KFUH
10,000 Sq. Ft.	KB	KFUH	KFUH	KFUH

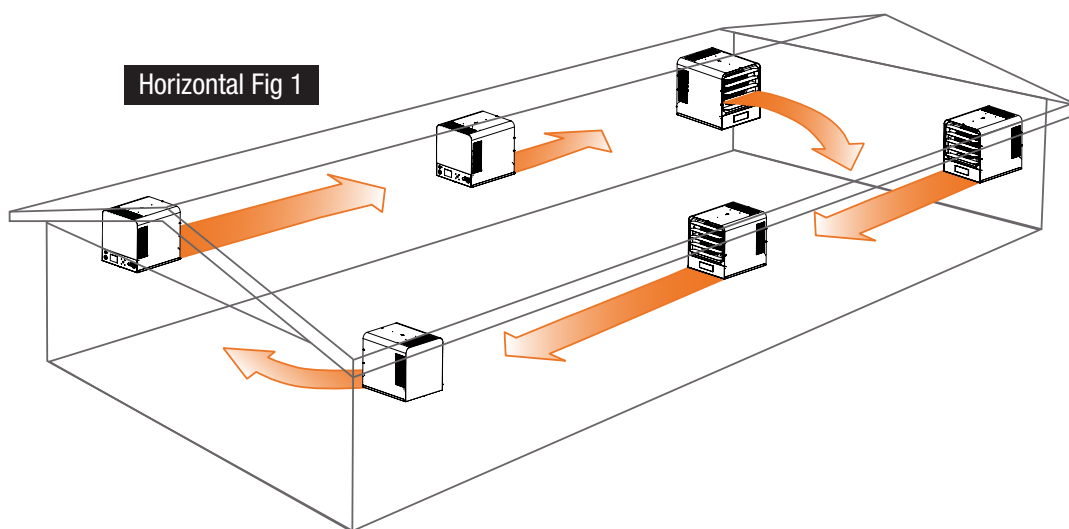

Vertical Fig 2

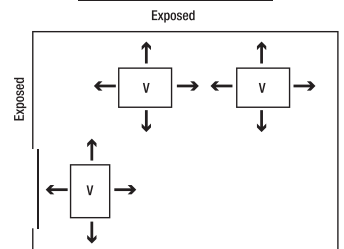

Dual Fig 3

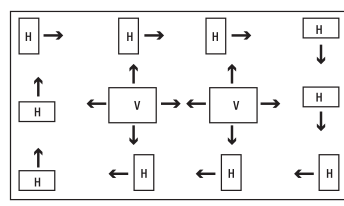

Garage/Shop Heater EKB Series



Model Code:

EKB	24	40	TB
A	B	C	D

A: Series
 B: 12 - 120V, 20 - 208V
 24 - 240V
 C: Watts (5000)
 D: TB- Thermostat & Bracket



- Quick heat element
- Long life unit bearing motor
- Patented Smart Limit® protection
- Aluminum fan blade
- Built-in thermostat
- Universal mounting bracket
- Standard color: black textured finish
- Safety sensor on each element
- 1-year limited warranty



The EKB Garage/Shop Heater

The EKB is designed to be an affordable, high-capacity garage / shop heater. Combining King's patented Smart Limit safety technology with dual NiChrome coil elements for rapid heat transfer, the EKB is ideal for many residential applications. The flow-through design efficiently moves air by pulling air from the back and sides of the heater and discharges it out the front, easily heating a large space. The built-in thermostat has a temperature range from 40 to 85 degrees. The universal mounting bracket can be wall or ceiling mounted at a minimum of 6 feet above the floor. Good air distribution and comfort is achieved by swiveling the bracket to specific work areas.

Ordering Information

	MODEL	UPC	VOLTS	WATTS	AMPS	WIRE	BREAKER SIZE	TEMP RISE	HEATING SQ FT
120V	EKB1230TB	16506	120	2850	24	10-2 w/ground	30 Amp 1 pole	40	500
	EKB1220TB	16507	120	1920	16	12-2 w/ground	20 Amp 1 pole	40	300
	EKB2050TB	16501	208	5000	24	10-2 w/ground	30 Amp 2 pole	80	750
208V	EKB2040TB	16503	208	3750	18	10-2 w/ground	30 Amp 2 pole	70	600
	EKB2030TB	16505	208	2850	14	12-2 w/ground	20 Amp 2 pole	50	500
	EKB2450TB	16500	240	5000	20	10-2 w/ground	30 Amp 2 pole	80	750
240V	EKB2440TB	16502	240	3850	16	12-2 w/ground	20 Amp 2 pole	70	600
	EKB2430TB	16504	240	2850	12	14-2 w/ground	15 Amp 2 pole	50	500

Engineering Specifications

Heating Elements: Rigid Muscovite Mica construction with 80-20 NiChrome heating wire provides quick heating without cold air start ups, heat is wiped from elements as fans slows to a stop. Manual reset Safety sensor on each element.

Thermostat: Factory installed single pole operation range 40 to 85 degrees F.

Unit Bearing Motor: Permanently lubricated, cast aluminum unit bearing, 6-watt output 4 pole motor, 1550 rpm, 20 cc oil supply.

Mounting Bracket: 18 ga steel, multiple mounting options - ceiling/wall.

CFM: 270 Maximum

Thermal Overload: Heaters shall be equipped with King's patented thermal overload Smart Limit Protection®, which disconnects elements and motor in the event normal operating temperatures are exceeded. If thermal overload trips due to abnormal operating temperatures, thermal overload shall remain open until manually reset by turning the heater off for 15 minutes. U.S. PATENT #6,748,163 B2 • CIPO PATENT #2,393,882

Case: 22 ga steel, inlet and outlet perforation, special side and top safety air inlets.

Exterior: Durable textured finish.

Approval: cULus (E41422)

Garage/Shop Heater EKB Series

Dimensional Data

EKB Unit Heater

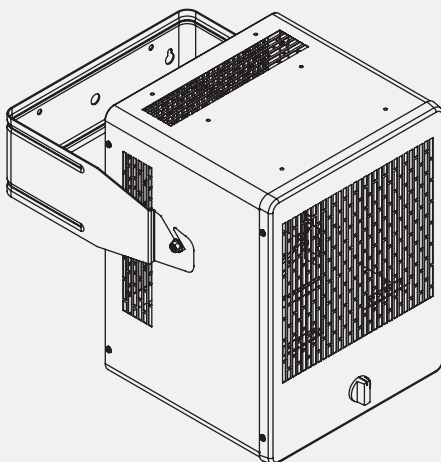

Heater case size
w/o bracket
Height: 13 5/8 in. / 34.6 cm
Width: 10 3/8 in. / 26.35 cm
Depth: 9 3/9 in. / 24.76 cm

Maximum Outside Dims
W/bracket and stat
Height: 18 3/4 in. / 47.62 cm
Width: 11 3/8 in. / 28.90 cm
Depth: 10 5/8 in. / 26.98 cm

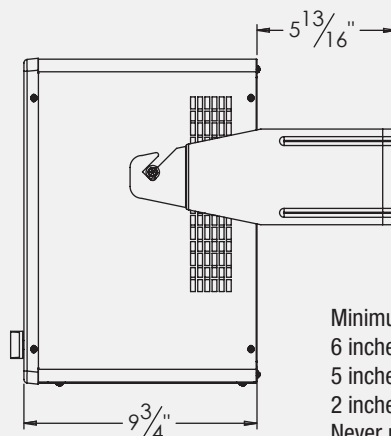
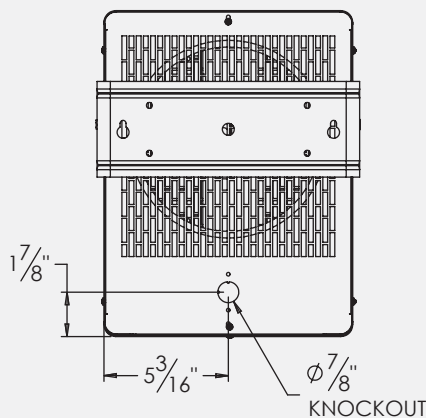
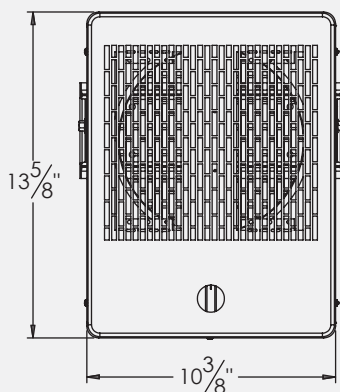

Bracket Information

Hole Sizes
* 1/2 in. / 1.27 cm 3 holes
+ 1/4 in. / .63 cm 4 holes

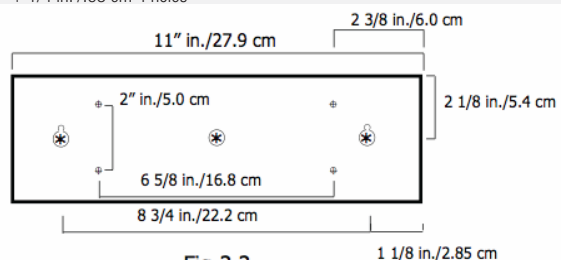
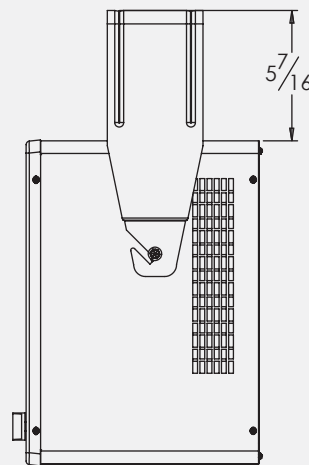

Fig 2.2



Minimum clearances from walls and ceiling
6 inches / 15.24 cm to the side
5 inches / 12.7 cm from the back
2 inches / 5.08 cm from ceiling
Never point heater at ceiling
Maintain clearance of at least 3 ft. in front
of heat outlet

MINIMUM CLEARANCE

From combustibles: 18" from front,
2" from top, 6" from sides
and 5" from rear.

Compact Unit Heater KBP Series

Model Code:

KBP	24	06
A	B	C
A: Series		
B: 12 - 120V 24 - 240V		
20 - 208V 27 - 277V		
C: Watts (950 to 6000)		

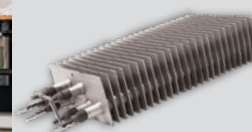
Pic-A-Watt
Steel Fin Element

- Pic-A-Watt® element
- Multiple wattage selection
- Long life cast iron motor
- Aluminum fan blade
- High accuracy built-in thermostat
- Powder-coated, textured finish
- Fan delay
- Patented Smart Limit Protection®
- Universal (wall/ceiling) mounting bracket
- Selector switch—fan/heat/off
- 5-year limited warranty
- Standard color: almond



Multiple Wattage Unit Heater

The KBP is the industry standard for multi-wattage garage / shop heaters. Designed for rugged performance, the flow-through design efficiently moves air by pulling air from the back of the heater and discharges it out the front, easily heating a large space. With high quality components suitable for both residential and commercial applications, it comes standard with a 3-position switch and an accurate built-in thermostat. The integral fan delay continues to dissipate heat from the elements during the cool down period, maximizing the heat exchange in the room. King's exclusive dual Pic-A-Watt steel fin elements allow customers to select from a range of wattage options, tailoring the heater to an area's specific heating requirements.

Ordering Information

MODEL	UPC	VOLTS	PHASE	WATTAGE	AMPS	WEIGHT (lbs.)
KBP1230	15191	120	1	2850•1900•950	24	26
KBP2406*	15190	240/208*	1	5700•4750•3800•2850•1900•950	24/27	24
KBP2006-3MP**	15193	240/208*	1-3	5700•2850	24/27	26
KBP2406-3MP**	15188	240/208*	1-3	5700•2850	24/27	25
KBP2704	15187	277	1	4000•3000•2000•1000	15	26
KBP4804-3MP**	15196	480***	1-3	4160	9/5	26
KBP4806-3MP**	15197	480***	1-3	6000	13/8	26

*Approved for 208V operation. Heater will draw 13% less Amps and 25% less wattage **3-Phase units do not have Heat / Fan / Off ***480 Volt models are 24 Volt control
 Minimum clearance from combustibles: 18" from front, 2" from top, 6" from sides and 5" from rear. Minimum clearance 6' from floor.

Engineering Specifications

Contractor shall supply and install KBP Series unit heaters manufactured by King Electrical Mfg. Company. Heaters shall be of the wattage and voltage as indicated on the plans.

Pic-A-Watt Heating Element: Exclusive King multi-tap element allows field adjustment to several wattages at time of installation. Steel sheath elements of various resistance are copper brazed to steel plate fins producing a multi-wattage heating element.

Built-in Thermostat: Single pole factory installed hydraulic capillary tube thermostat for precision heating control. Operating range 40° to 90° F.

Fan/Heat/Off Switch: 3-position switch provides heating and summer fan only operation.

Fan Delay Switch: The fan continues to operate after the thermostat shuts off in order to remove the residual heat left in the elements. Power must not be interrupted.

CFM: 270

Universal Mounting Bracket: Combination ceiling/wall bracket is included with every heater.

Unit Bearing Motor: Permanently lubricated, long life, unit bearing 4-Pole motor with 20 cc of oil. Enclosed rotor provides long-lasting, trouble-free operation. Thermally protected. 1300 RPM.

Electrically Held Smart Limit Protection: Heater shuts off when an over temperature condition exists and automatically resets when the normal operating temperature returns.

Tested: UL 2021

Approval: cCSAus

Accessories

MODEL	UPC	PHASE	WEIGHT (lbs.)
KBP-K1	15198	6 ft. cord/handle kit - 120V, 1-Phase, 30 Amp (Receptacle not included. See below)	2
KBP-K2	15199	6 ft. cord/handle kit - 240V, 1-Phase, 30 Amp (Receptacle included. See below)	2
KBP-RT	N/A	Provision for remote thermostat (line voltage)	N/A
*KBP-RTL1	N/A	Provision for remote thermostat - 1-Phase (24V)	N/A
*KBP-RTL3	N/A	Provision for remote thermostat - 3-Phase (24V)	N/A

*Factory installed only - Heat/Fan/Off activated at unit only - can not operate remotely

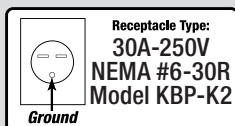
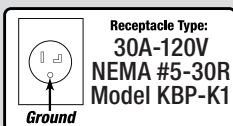

Dimensional Data

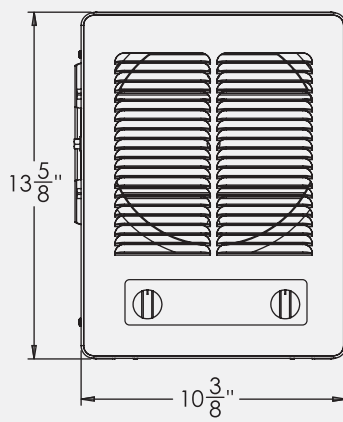
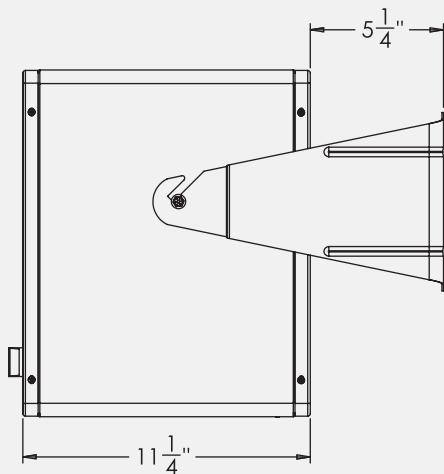
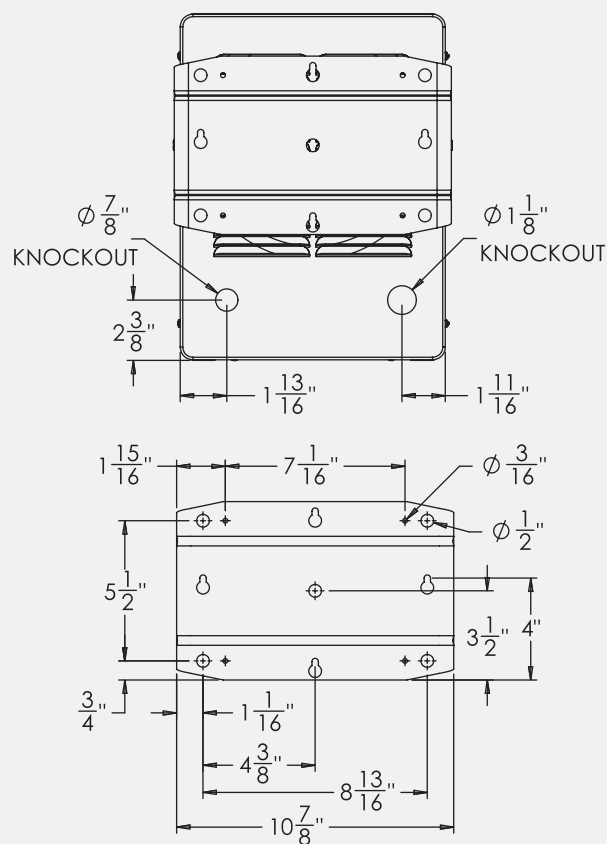
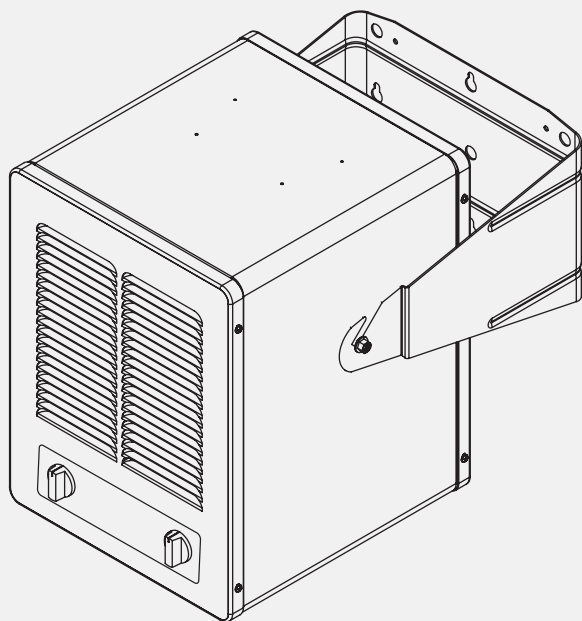

Compact Heavy Duty Garage Heater GH Series



Model Code:

GH	24	05	TB
A	B	C	D

A: Series
B: 24 - 240V
C: Watts
D: TB- Thermostat & Bracket



Full color consumer packaging

- Spiral finned element
- Permanently lubricated motor
- Patented Smart Limit® protection
- High efficiency aluminum fan blade
- Built-in thermostat
- Universal mounting bracket
- Standard color: Gray
- 3-year limited warranty
- Adjustable louvers
- Power & Over-temp indicating lights
- High /Low switch & fan delay*
- Prewired for remote thermostat option



The GH Compact Heavy Duty Unit Heater

The GH compact heavy duty unit heater is designed for use as primary or supplemental heat sources in large or exposed areas, including commercial stores, workshops, barns, storage shed and garages to prevent freezing. Spiral finned steel elements and high air volume (CFM) ensure efficient heat exchange producing cooler element operation, prolonging heater life. By combining the highest quality components with a dynamically balanced fan blade, the GH unit heater will provide years of trouble-free service. Includes both a power on indicating light and a red caution light that comes on if the heater stops due to the over temperature limit tripping. A universal wall/ceiling bracket provides for quick and simple installation. The built-in thermostat turns the heater on and off to maintain the desired room temperature or a remote wall thermostat can be used. The heater is prewired to easily convert from the built-in thermostat to a wall mounted line voltage thermostat. The heater can also be controlled by purchasing a transformer relay to operate a remote 24V wall thermostat. Refer to the installation instructions regarding the amperage requirements for use of both the line voltage thermostats and transformer relays.

Ordering Information - single phase

MODEL	UPC	KW	BTUH	PHASE	VOLTS	AMPS	MOTOR HP	CFM	TEMP. RISE	AIR THROW	MAX. MOUNT	WT. (lbs.)
*GH2405TB	22278	5	17	1	240	20.8/18	9W	400	40°	16ft.	8ft.	30.5
GH2407TB	22279	7.5	25.6	1	240	31.2/27	16W	600	40°	20ft.	9ft.	45.0
GH2410TB	22280	10	34.1	1	240	41.6/36.1	25W	725	44°	24ft.	10ft.	45.0

* High Low switch & fan delay not available in 5kW unit

Engineering Specifications

Contractor shall supply and install GH Series unit heaters manufactured by King Electrical Mfg. Company. Heaters shall be of the wattage and voltage as indicated on the plans.

Construction: All exterior and interior metal enclosure parts are made from 20 gauge electrogalvanized Steel with a rust inhibiting baked enamel finish. Rounded corners give it an attractive modern appearance.

Adjustable Outlet Louver: Louvers direct air up or down as needed for the heating application.

Rear Intake Screen: Heavy gauge steel screen protects against foreign objects making accidental contact with the rotating fan blade.

Spiral Fin Elements: The metal sheath element is copper brazed with spiral fins then molded into a coil configuration. This combination produces the best heat transfer while eliminating the potential for hot spots by positioning the element in the maximum airflow stream.

Aluminum Fan Blade: Axial flow-type fan mounted directly to the motor shaft for maximum efficiency.

Built-in Thermostat: Single pole factory installed hydraulic capillary tube thermostat for precision heating control. Operating range 40° to 90° F.

Red Over-temp Caution in Light: Only comes on if the high temperature safety limit has tripped.

Yellow Power on Light: Gives visual indication that the heater is turned on.

* **High/Low Switch:** Provided on 7.5kw & 10kw models. Low setting reduces wattage in half. Fan delay keeps fan running after thermostat cycles off to dissipate all the heat from the elements, making the heater more efficient and prolonging the life of the elements.

Compact Heavy Duty Garage Heater GH Series

Engineering Specifications Continued

Two Pole Contactor: Provided on 7.5kw & 10kw models. Breaks both L1 and L2 of the power supply wires, the control circuit operates at 240V.

Pre-Wired For Optional Room Thermostat: Heater shall include a 2-pole terminal block and is prewired to easily convert from the built-in thermostat to a wall mounted line voltage thermostat. The heater can also be controlled by purchasing a transformer relay to operate a remote 24V wall thermostat. Refer to the installation instructions regarding the amperage requirements for use of both the line voltage thermostats and transformer relays. For 240V heaters use transformer relay model 24A01G-3 or RC840T-240/U.

Electrically Held Thermal Overload: Heaters shall be equipped with King's patented Smart Limit Protection®, which disconnects the heater when an over temperature condition occurs. If the Smart Limit trips, it will remain open and will not automatically reset until the thermostat or circuit breaker is turned off for a few minutes. After the overload switch cools the power can be turned back on and the heater will operate again. This keeps the heater from repeatedly cycling allowing the user to

determine the cause of the over temperature condition such as an object being placed in front of heater.

Totally Enclosed Fan Motor: Permanently lubricated long life, unit bearing with 20cc of oil. Epoxy-coated motor with enclosed rotor resists moisture and corrosion for long-lasting, trouble-free operation.

Easy Installation: A quick access panel located on the bottom of the heater allows for quick wiring and easy maintenance for the life of the heater. Includes universal wall/ceiling bracket for simple installation.

Approvals: cULus (E41422)

• GH Wall/Ceiling Bracket Included

Unit heater brackets can be used for mounting on ceiling or wall. 3/8" threaded hole on top of unit heater can also be used with threaded rod to drop the unit closer to the floor.

Pre-Wired For Optional Line Voltage Room Thermostat*:

Connect a standard 240V single pole (SP) thermostat as a switch leg or a 3-wire SP electronic thermostat by providing both power legs, (L1 and L2) to drive the electronics.

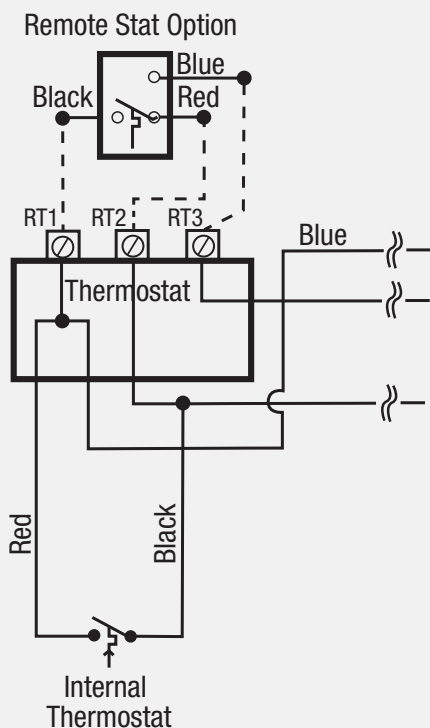

Note: Do not use a double pole thermostat. The incoming power supply is connected to the heater and is then switched through a contactor, so the thermostat will draw less than 1 amp through the control circuit.

*Above diagram reflects wiring for 7.5kW & 10kW heaters only. For 24V or line voltage remote thermostat wiring of 5kW units, refer to installation manual for details

Dimensional Data

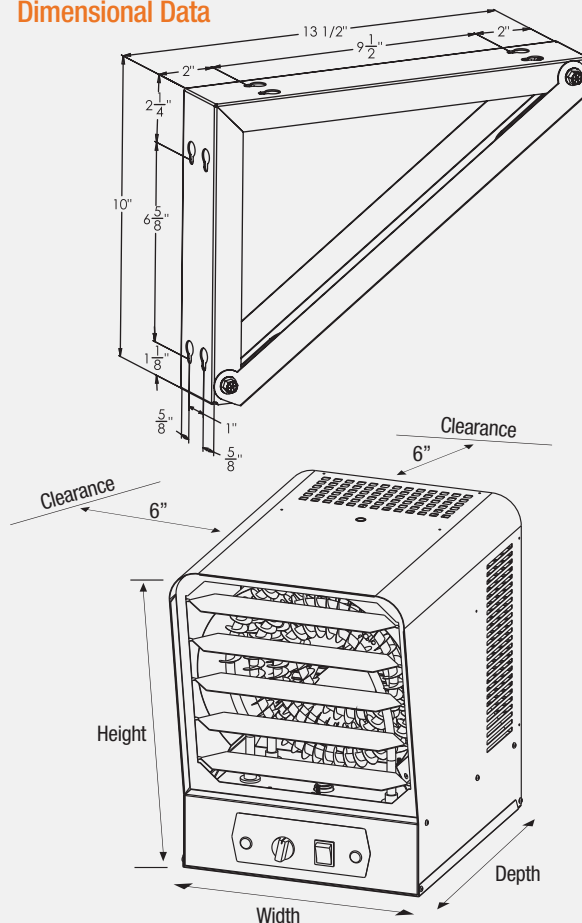

HEATER MODEL	HEIGHT	DEPTH	WIDTH
5kW	15.5"	12"	12.5"
7.5kW	16.25"	16.5"	12.5"
10kW	16.25"	16.5"	12.5"

Field Mount Accessories

MODEL	DESCRIPTION	WT. (lbs.)
24A01G-3	Electric Heat Relay For 240V	0.5
RC840T-240/U	Electric Heat Relay With a 24V-208/240V Transformer	0.5

Compact Heavy Duty Unit Heater SKB Series



Model Code:

SKB	24	05	1	T	B
A	B	C	D	E	F

- A: Series
- B: 20 - 208V
24 - 240V
- C: Watts
- D: Single Phase
- E: Thermostat
- F: Bracket



Kraft box packaging

- Spiral finned element
- Permanently lubricated motor
- Patented Smart Limit® protection
- High efficiency aluminum fan blade
- Built-in thermostat
- Universal mounting bracket
- Standard color: Gray
- 3-year limited warranty
- Adjustable louvers
- Power & Over-temp indicating lights
- High /Low switch & fan delay*
- Prewired for remote thermostat option



The SKB Compact Heavy Duty Unit Heater

The SKB compact heavy duty unit heater is designed for use as primary or supplemental heat sources in large or exposed areas, including commercial stores, workshops, barns, storage shed and garages to prevent freezing. Spiral finned steel elements and high air volume (CFM) ensure efficient heat exchange producing cooler element operation, prolonging heater life. By combining the highest quality components with a dynamically balanced fan blade, the SKB unit heater will provide years of trouble-free service. Includes both a power on indicating light and a red caution light that comes on if the heater stops due to the over temperature limit tripping. A universal wall/ceiling bracket provides for quick and simple installation. The built-in thermostat turns the heater on and off to maintain the desired room temperature or a remote wall thermostat can be used. The heater is prewired to easily convert from the built-in thermostat to a wall mounted line voltage thermostat. The heater can also be controlled by purchasing a transformer relay to operate a remote 24V wall thermostat. Refer to the installation instructions regarding the amperage requirements for use of both the line voltage thermostats and transformer relays.

Ordering Information - single phase

MODEL	UPC	KW	BTUH	PHASE	VOLTS	AMPS	MOTOR HP	CFM	TEMP. RISE	AIR THROW	MAX. MOUNT	WT. (lbs.)
*SKB2005-1-T-B	13413	5	17	1	208	24	9W	400	40°	16ft.	8ft.	30.5
SKB2007-1-T-B	13414	7.5	25.6	1	208	36.1	16W	600	40°	20ft.	9ft.	45.0
SKB2009-1-T-B	13415	9.2	31.4	1	208	44.2	25W	725	42°	24ft.	10ft.	45.0
SKB2405-1-T-B	13410	5	17	1	240/208*	20.8/18	9W	400	40°	16ft.	8ft.	30.5
SKB2407-1-T-B	13411	7.5	25.6	1	240/208*	31.2/27	16W	600	40°	20ft.	9ft.	45.0
SKB2410-1-T-B	13412	10	34.1	1	240/208*	41.6/36.1	25W	725	44°	24ft.	10ft.	45.0

*Dual rated heaters will draw 13% less amps and 25% less wattage when operated at 208V. *High Low switch & fan delay not available in 5kW unit

Engineering Specifications

Contractor shall supply and install SKB Series unit heaters manufactured by King Electrical Mfg. Company.

Construction: All exterior and interior metal enclosure parts are made from 20 gauge electrogalvanized Steel with a rust inhibiting baked enamel finish. Rounded corners give it an attractive modern appearance.

Adjustable Outlet Louver: Louvers direct air up or down as needed.

Rear Intake Screen: Heavy gauge steel screen protects against foreign objects making accidental contact with the rotating fan blade.

Spiral Fin Elements: The metal sheath element is copper brazed with spiral fins then molded into a coil configuration. This combination produces the best heat transfer while eliminating the potential for hot spots by positioning the element in the maximum airflow stream.

Aluminum Fan Blade: Axial flow-type fan mounted directly to the motor shaft for maximum efficiency.

Built-in Thermostat: Single pole factory installed hydraulic capillary tube thermostat for precision heating control. Operating range 40° to 90° F.

Red Caution Light: Comes on if high temperature safety limit trips.

Yellow Power on Light: Gives visual indication that the heater is turned on.

*** High/Low Switch:** Provided on 7.5kw & 10kw models. Low setting reduces wattage in half. Fan delay keeps fan running after thermostat cycles off to dissipate all the heat from the elements, making the heater more efficient and prolonging the life of the elements.

Compact Heavy Duty Unit Heater SKB Series

Engineering Specifications Continued

Two Pole Contactor: Provided on 7.5kw & 10kw models. Breaks both L1 and L2 of the power supply wires, the control circuit operates at 240V.

Pre-Wired For Optional Room Thermostat: Heater shall include a 2-pole terminal block and is prewired to easily convert from the built-in thermostat to a wall mounted line voltage thermostat. The heater can also be controlled by purchasing a transformer relay to operate a remote 24V wall thermostat. Refer to the installation instructions regarding the amperage requirements for use of both the line voltage thermostats and transformer relays. For 240V heaters use transformer relay model 24A01G-3 or RC840T-240/U. For 208V heaters use model 24A05E-1 or RC840T-240/U can be used on 7.5kW/10kW heaters.

Electrically Held Thermal Overload: Heaters shall be equipped with King's patented Smart Limit Protection®, which disconnects the heater when an over temperatures condition occurs. If the Smart Limit trips, it will remain open and will not automatically reset until the thermostat or circuit breaker is turned off for a few minutes. After the overload switch cools the power can be turned back on and the heater will operate again. This keeps the heater from repeatedly cycling allowing the user to

determine the cause of the over temperature condition such as an object being placed in front of heater.

Totally Enclosed Fan Motor: Permanently lubricated long life, unit bearing with 20cc of oil. Epoxy-coated motor with enclosed rotor resists moisture and corrosion for long-lasting, trouble-free operation.

Easy Installation: A quick access panel located on the bottom of the heater allows for quick wiring and easy maintenance for the life of the heater. Includes universal wall/ceiling bracket for simple installation.

Approvals: cULus (E41422)

• SKB Wall/Ceiling Bracket Included

Unit heater brackets can be used for mounting on ceiling or wall. 3/8" threaded hole on top of unit heater can also be used with threaded rod to drop the unit closer to the floor.

Pre-Wired For Optional Line Voltage Room Thermostat*:

Connect a standard 240V single pole (SP) thermostat as a switch leg or a 3-wire SP electronic thermostat by providing both power legs, (L1 and L2) to drive the electronics.

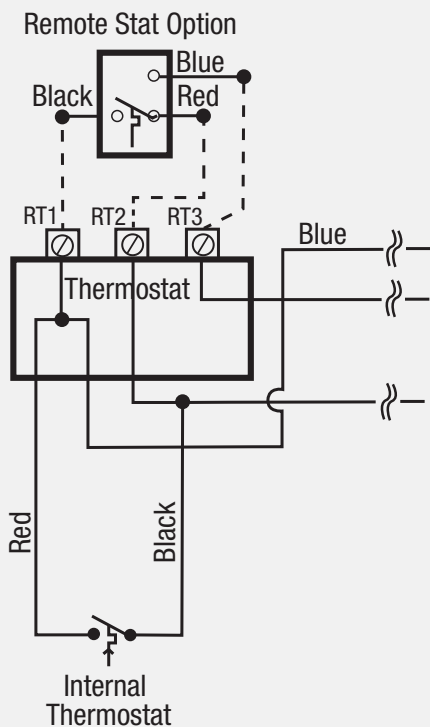

Note: Do not use a double pole thermostat. The incoming power supply is connected to the heater and is then switched through a contactor, so the thermostat will draw less than 1 amp through the control circuit.

*Above diagram reflects wiring for 7.5kW & 10kW heaters only. For 24V or line voltage remote thermostat wiring of 5kW units, refer to installation manual for details

Dimensional Data

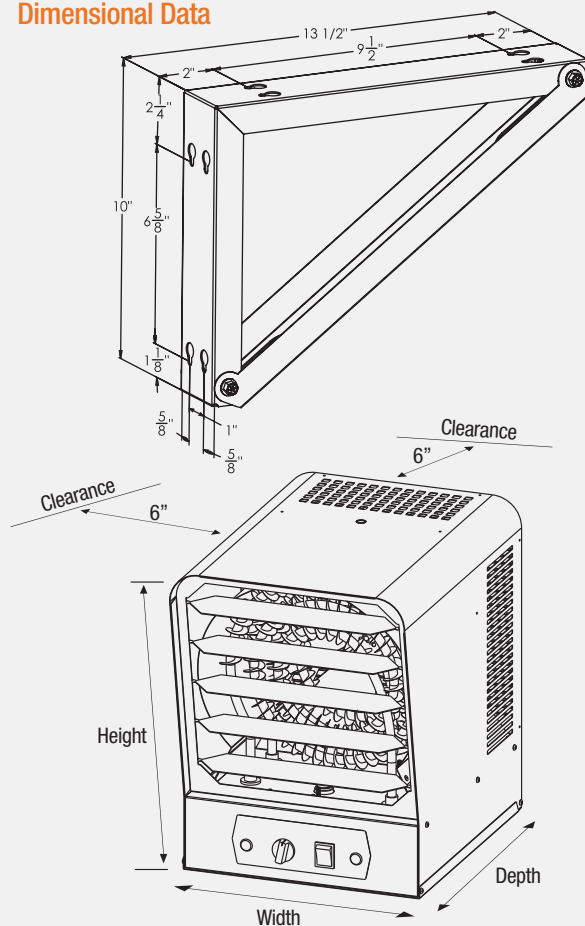

HEATER MODEL	HEIGHT	DEPTH	WIDTH
5kW	15.5"	12"	12.5"
7.5kW	16.25"	16.5"	12.5"
10kW	16.25"	16.5"	12.5"

Field Mount Accessories

MODEL	DESCRIPTION	WT. (lbs.)
24A01G-3	Electric Heat Relay For 240V	0.5
24A05E-1	Electric Heat Relay For 208V	0.5
RC840T-240/U	Electric Heat Relay With a 24V-208/240V Transformer	0.5

Heavy Duty Unit Heater KB Series



Model Code:

KB	48	10	-1	-B1
A	B	C	D	E

A: Series

B: 20 - 208V, 24 - 240/208V
27 - 277V, 48 - 480V

C: kiloWatts (4-66)

D: -1 = Single Phase
-3 = Three Phase

E: -B1 = Bracket



- Spiral finned element
- Long life unit bearing motor
- Manual limit
- Aluminum fan blade
- Built-in thermostat option
- Standard color: gray
- High-temp safety limit
- Universal mounting bracket included
- Tested to UL standards for safety
- Adjustable louvers
- 5-year limited warranty
- Hinged access cover



The KB Horizontal Unit Heater

King's KB series unit heaters are designed for use as primary or supplemental heat sources in large or exposed areas, including high-rise buildings, stores, warehouses, garages, water treatment and fire room vaults to prevent freezing. Spiral finned steel elements and high CFM ensure even air distribution producing cooler element operation, prolonging heater life. By combining the highest quality components, with a dynamically balanced fan blade, the KB unit heater will provide years of trouble-free service. Includes universal wall/ceiling bracket for simple installation.

Factory Installed Options

Power Contactor: Standard on heaters above 5kW and on all 3-Phase models; optional on 3 to 5kW 1-Phase heaters.

24 Volt Control: Standard on 480V heaters; optional on all other heaters.

Mounting: Standard universal bracket made from heavy gauge Steel.

Control Options

- 1-Pole or 2-Pole field installed thermostat temperature indicated label with 44°F energy code setting
- Padlocking disconnect
- Wall-mounted thermostat line or low voltage

NOTE: Multiple heaters can be controlled by a single thermostat if phasing is coordinated in the control wiring.

Engineering Specifications

Contractor shall supply and install KB Series unit heaters manufactured by King Electrical Mfg. Company. Heaters shall be of the wattage and voltage as indicated on the plans.

Construction: All exterior and interior metal enclosure parts are made from 20 gauge electrogalvanized Steel with a rust inhibiting baked enamel finish. Smooth rounded corners and protective edge trim give an attractive modern appearance.

Adjustable Outlet Louver: Louvers direct air up or down as needed for the heating application.

Rear Intake Screen: Heavy gauge steel screen protects against foreign objects making accidental contact with the rotating fan blade.

Spiral Fin Elements: The metal sheath element is copper brazed with spiral fins then molded into a coil configuration. This combination produces the best heat transfer while eliminating the potential for hot spots by positioning the element in the maximum airflow stream.

Totally Enclosed Fan Motor: Permanently lubricated long life, unit bearing with 20cc of oil. Epoxy-coated motor with enclosed rotor resists moisture and corrosion for long-lasting, trouble-free operation.

Staging: Two-Stage operation is available as an optional feature.

Aluminum Fan Blade: Axial flow-type fan mounted directly to the motor shaft for maximum efficiency.

Manual Thermal Cutout: Heaters shall be equipped with King's patented thermal overload Smart Limit Protection®, which disconnects elements and motor in the event normal operating temperatures are exceeded. If thermal overload trips due to abnormal operating temperatures, thermal overload shall remain open until manually reset by turning the heater off for 15 minutes. Automatically reset of thermal overloads, which allow the element to continue to cycle under abnormal conditions, will not be accepted.

Internal Controls: Magnetic contactors are standard on all 480V heaters, all 208V/1-Phase, 240V/1-Phase, 277V/1-Phase heaters above 6kW, and all 3-Phase heaters. The control voltage is equal to the line voltage (208, 240 or 277) except for 480V models where a transformer is provided for 24V control. Over 5kW the line voltage control is operating the contactor coil only and will draw only 1 Amp. See page 64 for control voltages.

Fusing: Internal circuit fusing is provided when the heater ampacity exceeds 48 Amps to comply with N.E.C. standards. A fan delay is provided standard on models 12.5-kW and above to dissipate residual heat from the heating elements.

Easy Installation: A hinged access panel located on the bottom of the heater allows for quick wiring and easy maintenance for the life of the heater. Includes universal wall/ceiling bracket for simple installation.

Approvals: cULus (E41422)

Heavy Duty Unit Heater KB Series

Ordering Information - single phase

MODEL	UPC	KW	BTUH	PHASE	VOLTS	AMPS	**THERMOSTAT CONTROL VOLTAGE	MOTOR HP	CFM	TEMP. RISE	AIR THROW	MAX. MOUNT HEIGHT	SIZE	WT. (lbs.)
KB2003-1	20928	3.3	11.1	1	208	15.8	208	9W	400	36°	15ft.	8ft.	A	30.5
KB2403-1	20928	3.3	11.1	1	240/208*	13.7	240	9W	400	36°	15ft.	8ft.	A	30.5
KB2703-1	20928	3.3	11.1	1	277	11.9	277	9W	400	36°	15ft.	8ft.	A	30.5
KB2004-1-B1	20928	4	13.5	1	208	19.2	208	9W	400	38°	15ft.	8ft.	A	30.5
KB2404-1-B1	13354	4	13.5	1	240/208*	16.6/14.4	240	9W	400	38°	15ft.	8ft.	A	30.5
KB2704-1-B1	13361	4	13.5	1	277	14.4	277	9W	400	38°	15ft.	8ft.	A	30.5
KB4804-1-B1	22091	4	13.5	1	480	8.3	24	9W	400	38°	15ft.	8ft.	A	30.5
KB2005-1-B1	13366	5	17	1	208	24	208	9W	400	40°	16ft.	8ft.	A	30.5
KB2405-1-B1	13374	5	17	1	240/208*	20.8/18	240	9W	400	40°	16ft.	8ft.	A	30.5
KB2705-1-B1	15240	5	17	1	277	18.1	277	9W	400	40°	16ft.	8ft.	A	30.5
KB4805-1-B1	13388	5	17	1	480	10.4	24	9W	400	40°	16ft.	8ft.	A	30.5
KB2007-1-B2	22242	7.5	25.6	1	208	36.1	208	16W	600	40°	20ft.	9ft.	B	45.0
KB2407-1-B2	22243	7.5	25.6	1	240/208*	31.2/27	240	16W	600	40°	20ft.	9ft.	B	45.0
KB2707-1-B2	22095	7.5	25.6	1	277	27	277	16W	600	40°	20ft.	9ft.	B	45.0
KB4807-1-B2	22244	7.5	25.6	1	480	15.6	24	16W	600	40°	20ft.	9ft.	B	45.0
KB2010-1-B2	13538	10	34.1	1	208	48.1	208	25W	725	44°	24ft.	10ft.	B	45.0
KB2410-1-B2	13546	10	34.1	1	240/208*	41.6/36.1	240	25W	725	44°	24ft.	10ft.	B	45.0
KB2710-1-B2	13554	10	34.1	1	277	36.1	277	25W	725	44°	24ft.	10ft.	B	45.0
KB4810-1-B2	13560	10	34.1	1	480	20.8	24	25W	725	44°	24ft.	10ft.	B	45.0
KB2012-1-B2	13616	12.5	42.7	1	208	60.1	208	35W	825	48°	30ft.	11ft.	C	46.5
KB2412-1-B2	13624	12.5	42.7	1	240/208*	52/45.1	240	35W	825	48°	30ft.	11ft.	C	46.5
KB2712-1-B2	22096	12.5	42.7	1	277	45.1	277	35W	825	48°	30ft.	11ft.	C	46.5
KB4812-1-B2	22097	12.5	42.7	1	480	26	24	35W	825	48°	30ft.	11ft.	C	46.5
KB2015-1-B2	13672	15	51.2	1	208	72.1	208	50W	925	51°	33ft.	12ft.	C	46.5
KB2415-1-B2	22098	15	51.2	1	240/208*	62.5/54.1	240	50W	925	51°	33ft.	12ft.	C	46.5
KB2715-1-B2	22099	15	51.2	1	277	54.2	277	50W	925	51°	33ft.	12ft.	C	46.5
KB4815-1-B2	22100	15	51.2	1	480	31.3	24	50W	925	51°	33ft.	12ft.	C	46.5

*Dual rated heaters will draw 13% less amps and 25% less wattage when operated at 208V.

Maximum mounting height is manufacturer's recommendation

**Over 5kw line voltage control is operating the contactor coil only, and will draw under 1 amp.

Dimensional Data

Twin Unit Size F & G

HEATER SIZE	HEIGHT	DEPTH	WIDTH
A	16.5"	11"	15"
B	16.5"	13.5"	15"
C	16.5"	18"	15"
E	20.5"	18"	15"
F	18.5"	18"	30"
G	16.5"	18"	30"

KBB-1 / KBB-2 / KBB-3
 Unit heater brackets can be used for mounting on ceiling or wall. 3/8" threaded hole on top of unit heater can also be used with threaded rod to drop the unit closer to the floor. Refer to bracket selection chart.

Heavy Duty Unit Heater KB Series

Ordering Information - three phase

MODEL	UPC	KW	BTUH	PHASE	VOLTS	AMPS	**THERM. CONTROL VOLTAGE	MOTOR HP	CFM	TEMP. RISE	AIR THROW	MAX. MOUNT HEIGHT	*SIZE	WT. (lbs.)
KB4803-3MP-B2	13318	3	10.2	1-3	480	6.3	24	5W	400	37°	14ft.	8ft.	C	46.5
KB2005-3MP-B2	13370	5	17.1	1-3	208	24 & 13.9	208	9W	400	40°	16ft.	8ft.	C	46.5
KB2405-3MP-B2	22102	5	17.1	1-3	240/208*	20.8/18 & 18/15.6	240	9W	400	40°	16ft.	8ft.	C	46.5
KB4805-3MP-B2	13392	5	17.1	1-3	480	10.4 & 6	24	9W	400	40°	16ft.	8ft.	C	46.5
KB2007-3MP-B2	13450	7.5	25.6	1-3	208	36.1 & 20.8	208	16W	600	40°	20ft.	9ft.	C	46.5
KB2407-3MP-B2	13458	7.5	25.6	1-3	240/208*	31.2/27 & 18/15.6	240	16W	600	40°	20ft.	9ft.	C	46.5
KB4807-3MP-B2	13472	7.5	25.6	1-3	480	15.6 & 24	24	16W	600	40°	20ft.	9ft.	C	46.5
KB2010-3MP-B2	13542	10	34.1	1-3	208	27.7	208	25W	725	44°	24ft.	10ft.	C	46.5
KB2410-3MP-B2	13550	10	34.1	1-3	240/208*	41.6/36.1 & 24/20.8	240	25W	725	44°	24ft.	10ft.	C	46.5
KB4810-3MP-B2	13564	10	34.1	1-3	480	20.8 & 12	24	25W	725	44°	24ft.	10ft.	C	46.5
KB2012-3-B2	13620	12.5	42.7	3	208	34.6	208	35W	825	48°	30ft.	11ft.	C	46.5
KB2412-3-B2	13632	12.5	42.7	3	240/208*	30/26	240	35W	825	48°	30ft.	11ft.	C	46.5
KB4812-3MP-B2	13644	12.5	42.7	1-3	480	26 & 15	24	35W	825	48°	30ft.	11ft.	C	46.5
KB2015-3-B2	13676	15	51.2	3	208	41.6	208	50W	925	51°	33ft.	12ft.	C	46.5
KB2415-3-B2	13688	15	51.2	3	240/208*	36/31.2	240	50W	925	51°	33ft.	12ft.	C	46.5
KB4815-3MP-B2	22104	15	51.2	1-3	480	18	24	50W	925	51°	33ft.	12ft.	C	46.5
KB2020-3-B2	13734	20	68.3	3	208	55.5	208	¼HP	1100	57°	47ft.	13ft.	E	55.0
KB2420-3-B2	13738	20	68.3	3	240/208*	48.1/41.6	240	¼HP	1100	57°	47ft.	13ft.	E	55.0
KB4820-3MP-B2	22105	20	68.3	1-3	480	24	24	¼HP	1100	57°	47ft.	13ft.	E	55.0
KB2025-3-B2	22106	24	85.3	3	208	69.4	208	(2) 35W	1350	58°	41ft.	14ft.	F	60.5
KB2425-3-B2	13784	24	85.3	3	240/208*	60.1/52.1	240	(2) 35W	1350	58°	41ft.	14ft.	F	60.5
KB4825-3-B2	22107	24	85.3	3	480	30.1	24	(2) 35W	1350	58°	41ft.	14ft.	F	60.5
KB2030-3-B2	13806	30	102.4	3	208	83.3	208	(2) 50W	1800	53°	48ft.	15ft.	F	60.5
KB2430-3-B2	13810	30	102.4	3	240/208*	72.1/62.5	240	(2) 50W	1800	53°	48ft.	15ft.	F	60.5
KB4830-3-B2	13816	30	102.4	3	480	24	24	(2) 50W	1800	53°	48ft.	15ft.	F	60.5
KB2040-3-B2	22108	40	136.5	3	208	111	208	(2) ¼HP	2200	57°	53ft.	15ft.	G	70.0
KB2440-3-B2	22109	40	136.5	3	240/208*	96.2/83.3	240	(2) ¼HP	2200	57°	53ft.	15ft.	G	70.0
KB4840-3-B2	22110	40	136.5	3	480	48.1	24	(2) ¼HP	2200	57°	53ft.	15ft.	G	70.0

6" minimum clearance to walls and ceilings.

Over 5KW line voltage control is operating the contactor coil only, and will draw under 1 AMP.

*Dual rated heaters will draw 13% less amps and 25% less wattage when operated at 208V.

Field Mount Accessories

MODEL	UPC	DESCRIPTION	WT. (lbs.)
KBB-1	15192	Universal Wall/Ceiling Small Mounting Bracket (for heaters with size A heaters)	1.9
KBB-2	15195	Universal Wall/Ceiling Large Mounting Bracket (for heaters with size B, C, and E)	2.6
KBB-3	13488	Universal Wall/Ceiling Large Mounting Bracket (for heaters with size F & G)	3.9
KBT	15189	Capillary Bulb-StyleThermostat Kit (single pole single throw) 25 Amp	
KBT-2	18209	Capillary Bulb-StyleThermostat Kit (double pole single throw) 25 Amp	0.5

Bracket Selection Chart

BRACKET #	HEATER KW SIZE USED WITH	BRACKET DIMENSIONS											
		L	W	H	A	B	C	D	E	F	X	Y	Z
KBB-1	3 to 5 kW (1 phase)	12½"	2 ₁₅ / ₁₆ "	10 ₁ / ₁₆ "	1 ₃ / ₁₆ "	7"	1 ₇ / ₈ "	1 ₇ / ₈ "	9¼"	1 ₅ / ₈ "	¾"	1"	½"
KBB-2	7.5 to 15 kW (1 phase) 3 to 20 kW (3 phase)	16 ₇ / ₈ "	2 ₁₅ / ₁₆ "	10 ₁ / ₈ "	1¼"	7"	1 ₇ / ₈ "	1 ₅ / ₈ "	13 ₅ / ₈ "	1 ₅ / ₈ "	¾"	1"	1½"
KBB-3	25 to 40 kW (3 phase)	19½"	4 ₃ / ₁₆ "	13 ₃ / ₁₆ "	1 ₅ / ₁₆ "	10"	1 ₇ / ₈ "	1 ₅ / ₈ "	16¼"	1 ₁ / ₈ "	11 ₁ / ₁₆ "	1"	2"

Heavy Duty Unit Heater KB Series

Factory Options

ADD SUFFIX:	DESCRIPTION
-B1	Mounting Bracket KBB-1 (included with heater size A and C)
-B2	Mounting Bracket KBB-2 (included with heater size B, and E)
-B3	Mounting Bracket KBB-3 (included with heater size F and G)
-SFR	Control Relay and 24V Transformer for Remote Summer Fan Operation
-CX	Power Contactor for 3 kW - 5kW 1-Phase Models (Line Voltage Coil)
-CT24	Transformer that Converts 208, 240 and 277 Volts to 24 Volt Control Circuit {add power contactor (-CX) for 3 kW - 5kW 1-Phase models}
-DS40	60 Amp, 3-Pole Disconnect Switch w/Padlock Provision
-DS60	60 Amp, 3-Pole Disconnect Switch w/Padlock Provision
-DS80	80 Amp, 3-Pole Disconnect Switch w/Padlock Provision
-DS100	100 Amp, 3-Pole Disconnect Switch w/Door Interlock and Padlock Provision

Electronic Unit Heater KB ECO2S Series



Model Code:

KB	24	04	-1	-B2	-ECO
A	B	C	D	E	F

A: Series
B: 20 - 208V, 24 - 240/208V
C: kiloWatts (4 - 15)
D: -1 = Single Phase
E: -B2 = Universal Bracket
F: -ECO = Electronic Control



- ECO2S electronic controller
- Energy efficient 2-stage heating
- Remote control included
- Large LED display
- Patented Smart Limit® Protection
- Auto reset high limit
- Unit bearing motor
- Standard color: textured gray
- Fan only and timer modes
- Adjustable louvers
- Spiral finned heat elements
- Universal bracket included
- 5-year limited warranty



ECO2S 2-Stage Garage Heater with IR Remote Control

The ECO2S KB series unit heaters offers unparalleled performance, energy efficiency and user control by incorporating another **King innovation**, the in-built ECO2S electronic thermostat with remote control. Offering energy efficient 2-stage heating, with Eco mode that automatically uses the lowest wattage needed to heat the room, integrated fan only and timer modes, as well as a remote control for simple operation. Designed for use as primary or supplemental heat sources in warehouses, stores or large garages spaces. Spiral steel elements and high CFM ensure even air distribution producing cooler element operation which prolongs the life of the heater. By combining the highest quality components, with a dynamically balanced fan blade, the KB ECO2S unit heater will provide years of trouble-free service and keep heating bills to a minimum. Includes universal wall/ceiling bracket for simple installation.

ECO2S Electronic Controller Features:

- Electronic control for accuracy
- Energy-saving automatic 2-stage heating
- Large LED display
- Remote control and wall bracket included
- Thermostat timer mode (1-9 Hours)
- Fan only mode
- Built-In fan delay



Engineering Specifications

Contractor shall supply and install KB ECO2S Series garage heaters manufactured by King Electrical Mfg. Company. Heaters shall be of the wattage and voltage as indicated on the plans.

Construction: All exterior and interior metal enclosure parts are made from 20 gauge electrogalvanized Steel with a rust inhibiting baked enamel finish. Smooth rounded corners and protective edge trim give an attractive modern appearance.

Adjustable Outlet Louver: Louvers direct air up or down as needed for the heating application. Rear Intake Screen: Heavy gauge steel screen protects against foreign objects making accidental contact with the rotating fan blade.

Spiral Fin Elements: The metal sheath element is copper brazed with spiral fins then molded into a coil configuration. This combination produces the best heat transfer while eliminating the potential for hot spots by positioning the element in the maximum airflow stream.

Totally Enclosed Fan Motor: Permanently lubricated long life unit bearing motor with 20cc of oil. Epoxy-coated motor with enclosed rotor resists moisture and corrosion for long-lasting, trouble-free operation.

Aluminum Fan Blade: 5 blade fan mounted directly to the motor shaft for maximum efficiency.

Auto-Reset Thermal Cutout: Power is disconnected from the element if an overheated condition occurs. The fan continues to run to dissipate excess heat from the element. The element is re-energized automatically when the normal operating temperature returns.

Electronic Control: Up, down temperature mode. Start/Stop. Standard on all heaters. The control voltage is equal to the line voltage (208, 240) for 5kW models. Over 5kW the line voltage control is operating the contactors.

Easy Installation: A quick access panel located on the bottom of the heater allows for quick wiring and easy maintenance for the life of the heater. Includes universal wall/ceiling bracket for simple installation.

Approvals: cULus (E41422)

Electronic Unit Heater KB ECO2S Series

Ordering Information

MODEL	UPC	kilo WATTS	BTUH	PHASE	VOLTS	AMPS	MOTOR HP	CFM	TEMP. RISE	AIR THROW	MAX MOUNT HEIGHT	SIZE	WT. (lbs.)
KB2404-1-B2-ECO	22037	4	13.5	1	240/208*	16.6/14.4	9W	400	38°F	15 ft.	8 ft.	B	28.5
KB2004-1-B2-ECO	22045	4	13.5	1	208	19.2	9W	400	38°F	15 ft.	8 ft.	B	28.5
KB2405-1-B2-ECO	22038	5	17	1	240/208*	20.8/18	9W	400	40°F	16 ft.	8 ft.	B	28.5
KB2005-1-B2-ECO	22046	5	17	1	208	24	9W	400	40°F	16 ft.	8 ft.	B	28.5
KB2407-1-B2-ECO	22040	7.5	25.6	1	240/208*	31.2/27	16W	600	40°F	20 ft.	9 ft.	B	28.5
KB2007-1-B2-ECO	22048	7.5	25.6	1	208	36.1	16W	600	40°F	20 ft.	9 ft.	B	29
KB2410-1-B2-ECO	22042	10	34.1	1	240/208*	41.6/36.1	25W	725	44°F	24 ft.	10 ft.	B	42
KB2010-1-B2-ECO	22050	10	34.1	1	208	48.1	25W	725	44°F	24 ft.	10 ft.	B	34
KB2412-1-B2-ECO	22043	12.5	42.7	1	240/208*	52/45.1	35W	825	48°F	30 ft.	11 ft.	C	32
KB2012-1-B2-ECO	22051	12.5	42.7	1	208	60.1	35W	825	48°F	30 ft.	11 ft.	C	32
KB2415-1-B2-ECO	22044	15	51.2	1	240/208*	62.5/54.1	50W	925	51°F	33 ft.	12 ft.	C	37
KB2015-1-B2-ECO	22052	15	51.2	1	208	72.1	50W	925	51°F	33 ft.	12 ft.	C	37

*Dual rated heaters will draw 13% less amps and 25% less wattage when operated at 208V.

Replacement Accessories

MODEL	DESCRIPTION	WT. (lbs.)
61747	ECO2S Replacement Infrared Remote Control	0.125

Bracket Selection Chart

BRACKET #	HEATER KW SIZE USED WITH	BRACKET DIMENSIONS											
		L	W	H	A	B	C	D	E	F	X	Y	Z
KBB-2	4 to 15 kW (1 phase)	16 ⁷ / ₈ "	2 ¹⁵ / ₁₆ "	10 ¹ / ₈ "	1 ¹ / ₄ "	7"	1 ⁷ / ₈ "	1 ⁵ / ₈ "	13 ⁵ / ₈ "	1 ⁵ / ₈ "	3 ⁴ / ₄ "	1"	1 ¹ / ₂ "

Dimensional Data

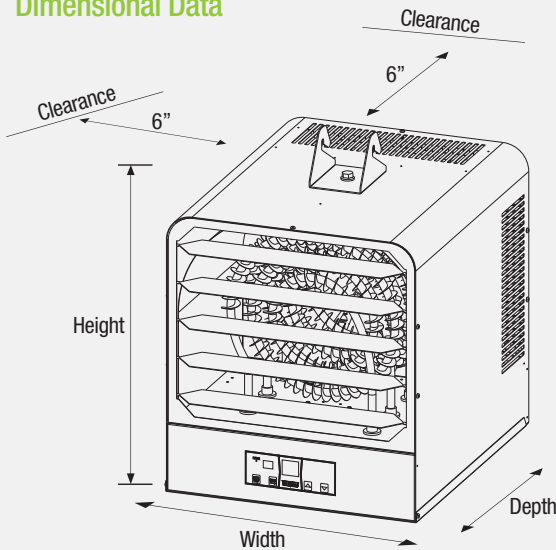

• KBB-2 Wall/Ceiling Bracket Included

Garage heater brackets can be used for mounting on ceiling or wall. 3/8" threaded hole on top of unit heater can also be used with threaded rod to drop the unit closer to the floor.

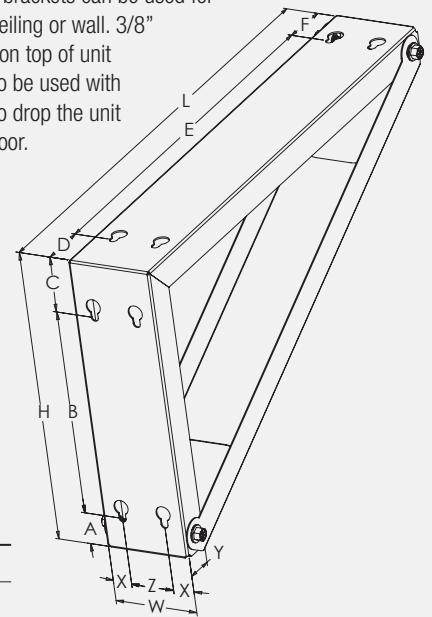

HEATER SIZE	HEIGHT	DEPTH	WIDTH
B	16.5"	13.5"	15"
C	16.5"	18"	15"



Energy Saving Eco Comfort

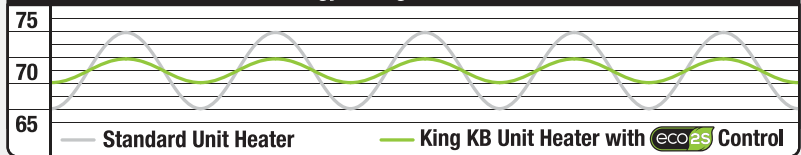

*Reduces temperature swings

Electronic Unit Heater KB Platinum Series



Model Code:

KB	48	10	-1	-P	-FB
A	B	C	D	E	F

A: Series
B: 20 - 208V, 24 - 240/208V
 27 - 277V, 48 - 480V
C: kiloWatts (4-66)
D: -1 = Single Phase
 -3 = Three Phase
 -3MP = 1-3 Phase
E: -B1 = Platinum Controller
F: FB = Fuse Block



- Electronic temperature controller
- Large LED display
- Remote control included
- Fan only & timer modes
- Fan delay
- Patented Smart Limit Protection®
- Adjustable louvers
- Unit bearing motor
- Spiral finned heat elements
- Standard color: textured gray
- Universal mounting bracket included
- 5-year limited warranty



The KB Platinum Horizontal Unit Heater

King's KB Platinum series unit heaters are the most full-featured unit heaters on the market, with in-built electronic thermostat for accuracy and remote control for simple operation. With integrated summer fan only and thermostat timer mode, the KB Platinum has you covered. Designed for use as primary or supplemental heat sources in large or exposed areas, including high-rise buildings, stores, warehouses, garages, water treatment and fire room vaults to prevent freezing. Spiral finned steel elements and high CFM ensure even air distribution producing cooler element operation, prolonging heater life. By combining the highest quality components, with a dynamically balanced fan blade, the KB Platinum unit heater will provide years of trouble-free service. Includes universal wall/ceiling bracket for simple installation.

Platinum Electronic Controller Features

- Electronic control for accuracy
- Thermostat timer mode (1-9 Hours)
- Summer Fan only mode
- Large LED display
- Built-In fan delay
- Remote control and wall/ceiling bracket included
- Heaters above 20kW are ECO2S 2-stage heaters



Engineering Specifications

Contractor shall supply and install KB Series unit heaters manufactured by King Electrical Mfg. Company. Heaters shall be of the wattage and voltage as indicated on the plans.

Construction: All exterior and interior metal enclosure parts are made from 20 gauge electrogalvanized Steel with a rust inhibiting baked enamel finish. Smooth rounded corners and protective edge trim give an attractive modern appearance.

Adjustable Outlet Louver: Louvers direct air up or down as needed for the heating application.

Rear Intake Screen: Heavy gauge steel screen protects against foreign objects making accidental contact with the rotating fan blade.

Spiral Fin Elements: The metal sheath element is copper brazed with spiral fins then molded into a coil configuration. This combination produces the best heat transfer while eliminating the potential for hot spots by positioning the element in the maximum airflow stream.

Totally Enclosed Fan Motor: Permanently lubricated long life, unit bearing with 20cc of oil. Epoxy-coated motor with enclosed rotor resists moisture and corrosion for long-lasting, trouble-free operation.

Aluminum Fan Blade: Axial flow-type fan mounted directly to the motor shaft for maximum efficiency.

Thermal Overload: Heaters shall be equipped with King's patented thermal overload Smart Limit Protection®, which disconnects elements and motor in

the event normal operating temperatures are exceeded. If thermal overload trips due to abnormal operating temperatures, thermal overload shall remain open until manually reset by turning the heater off for 15 minutes.

Automatically reset of thermal overloads, which allow the element to continue to cycle under abnormal conditions, will not be accepted.

Internal Controls: Magnetic contactors are standard on all 480V heaters, all 208V/1-Phase, 240V/1-Phase, 277V/1-Phase heaters above 6kW, and all 3-Phase heaters. The control voltage is equal to the line voltage (208, 240 or 277) except for 480V models where a transformer is provided for 24V control. Over 5kW the line voltage control is operating the contactor coil only and will draw only 1 Amp. See page 64 for control voltages.

Fusing: Internal circuit fusing is provided when the heater ampacity exceeds 48 Amps to comply with N.E.C. standards. A fan delay is provided standard on models 12.5-kW and above to dissipate residual heat from the heating elements.

Easy Installation: A quick access panel located on the bottom of the heater allows for quick wiring and easy maintenance for the life of the heater. Includes universal wall/ceiling bracket for simple installation.

Approvals: cULus (E41422)

Electronic Unit Heater KB Platinum Series

Ordering Information - single phase

MODEL	UPC	KW	BTUH	PHASE	VOLTS	AMPS	MOTOR HP	CFM	TEMP. RISE	AIR THROW	MAX. MOUNT HEIGHT	*SIZE	WT. (lbs.)
KB2003-1-P	13312	3	10.2	1	208	14.4	9W	400	37°	15ft.	8ft.	A	30.5
KB2403-1-P	13313	3	10.2	1	240/208*	12.5	9W	400	37°	15ft.	8ft.	A	30.5
KB2703-1-P	13314	3	10.2	1	277	10.8	9W	400	38°	15ft.	8ft.	A	30.5
KB2004-1-P	13315	4	13.5	1	208	19.2	9W	400	38°	15ft.	8ft.	A	30.5
KB2404-1-P	13316	4	13.5	1	240/208*	16.7/14.4	9W	400	38°	15ft.	8ft.	A	30.5
KB2704-1-P	13317	4	13.5	1	277	14.4	9W	400	38°	15ft.	8ft.	A	30.5
KB2005-1-P	13323	5	17	1	208	24.0	9W	400	40°	16ft.	8ft.	A	30.5
KB2405-1-P	13324	5	17	1	240/208*	20.8/18	9W	400	40°	16ft.	8ft.	A	30.5
KB2705-1-P	13325	5	17	1	277	18.1	9W	400	40°	16ft.	8ft.	A	30.5
KB2007-1-P	13326	7.5	25.6	1	208	36.1	16W	600	40°	20ft.	9ft.	B	45.0
KB2407-1-P	13327	7.5	25.6	1	240/208*	31.3/27	16W	600	40°	20ft.	9ft.	B	45.0
KB2707-1-P	13328	7.5	25.6	1	277	27.1	16W	600	40°	20ft.	9ft.	B	45.0
KB2010-1-P	13329	9.98	34.1	1	208	48.0	25W	725	44°	24ft.	10ft.	B	45.0
KB2410-1-P	13330	10	34.1	1	240/208*	41.6/36.1	25W	725	44°	24ft.	10ft.	B	45.0
KB2710-1-P	13331	10	34.1	1	277	36.1	25W	725	44°	24ft.	10ft.	B	45.0
KB2012-1-P-FB	13404	12.5	42.7	1	208	60.1	25W	825	48°	30ft.	11ft.	C	50.0
KB2412-1-P-FB	13405	12.5	42.7	1	240/208*	52.1/45.1	35W	825	48°	30ft.	11ft.	C	50.0
KB2015-1-P-FB	13406	15	51.2	1	208	72.1	50W	925	51°	33ft.	12ft.	C	50.0
KB2415-1-P-FB	13407	15	51.2	1	240/208*	62.5/54.1	50W	925	51°	33ft.	12ft.	C	50.0
KB2003-3MP-P	13332	3	10.2	1-3	208	14.4/8.3	9W	400	37°	14ft.	8ft.	C	45.0
KB2403-3MP-P	13333	3	10.2	1-3	240/208*	62.5/54.1	9W	400	37°	14ft.	8ft.	C	45.0
KB4803-3MP-P	13348	3	10.2	1-3	480	6.3/3.6	9W	400	37°	14ft.	8ft.	C	45.0
KB2005-3MP-P	13334	5	17.1	1-3	208	24 & 13.9	9W	400	40°	16ft.	8ft.	C	45.0
KB2405-3MP-P	13335	5	17.1	1-3	240/208*	20.8/18 & 18/15.6	9W	400	40°	16ft.	8ft.	C	45.0
KB4805-3MP-P	13349	5	17.1	1-3	480	10.4 & 6.0	9W	400	40°	16ft.	8ft.	C	45.0
KB2007-3MP-P	13336	7.5	25.6	1-3	208	36.1 & 20.8	16W	600	40°	20ft.	9ft.	C	46.5
KB2407-3MP-P	13337	7.5	25.6	1-3	240/208*	31.2/27 & 18/15.6	16W	600	40°	20ft.	9ft.	C	46.5
KB4807-3MP-P	13350	7.5	25.6	1-3	480	31.3/18.1	16W	925	51°	33ft.	12ft.	C	46.5
KB2410-3MP-P	13338	10	34.1	1-3	240/208*	41.7/36.1 & 24.1/20.8	25W	725	44°	24ft.	10ft.	C	46.5
KB4810-3MP-P	13351	10	34.1	1-3	480	20.8 & 12	25W	725	44°	24ft.	10ft.	C	46.5
KB4812-3MP-P	13401	12.5	42.7	1-3	480	26 & 15	25W	825	48°	30ft.	11ft.	C	46.5
KB4815-3MP-P	13402	15	51.2	1-3	480	31.3 & 18.1	50W	925	51°	33ft.	12ft.	C	46.5
KB2010-3MP-P	13343	9.98	47.9	3	208	27.7	25W	825	48°	30ft.	11ft.	C	46.5
KB2012-3-P	13344	12.5	42.7	3	208	34.7	35W	825	48°	30ft.	11ft.	C	50.0
KB2412-3-P	13345	12.5	42.7	3	240/208*	30.1/26	35W	825	48°	30ft.	11ft.	C	50.0
KB2015-3-P	13346	15	51.2	3	208	41.7	50W	925	51°	33ft.	12ft.	C	50.0
KB2415-3-P	13347	15	51.2	3	240/208*	36.1/31.2	50W	925	51°	33ft.	12ft.	C	50.0
KB2020-3-P-FB	13408	20	68.3	3	208	55.6	1/4 HP	1100	57°	47ft.	13ft.	E	55.0
KB2420-3-P-FB	13409	20	68.3	3	240/208*	48.2/41.6	1/4 HP	1100	57°	47ft.	13ft.	E	55.0
KB4820-3-P	13416	20	68.3	3	480	24.1	1/4 HP	1100	57°	47ft.	13ft.	E	55.0
*KB2025-3-P-FB	13417	25	85.3	3	208	69.5	(2) 35W	1100	57°	47ft.	13ft.	F	60.5
KB2425-3-P-FB	13418	25	85.3	3	240/208	60.2/52.1	(2) 35W	1350	58°	41ft.	14ft.	F	60.5
*KB4825-3-P	13439	25	85.3	3	480	30.1	(2) 35W	1350	58°	41ft.	14ft.	F	60.5
*KB2030-3-P-FB	13419	30	102.4	3	208	83.4	(2) 50W	1800	53°	48ft.	15ft.	F	60.5
KB2430-3-P-FB	13420	30	102.4	3	240/208	72.3/62.5	(2) 50W	1800	53°	48ft.	15ft.	F	60.5
*KB4830-3-P	13440	30	102.4	3	480	36.1	(2) 50W	1800	53°	48ft.	15ft.	F	60.5
*KB2440-3-P-FB	13438	40	136.5	3	240	96.3/83.3	(2) 1/4 HP	2200	57°	53ft.	15ft.	F	60.5
*KB4840-3-P-FB	13441	40	136.5	3	480	48.2	(2) 1/4 HP	2200	57°	53ft.	15ft.	G	60.5

Maximum mounting height is manufacturer's recommendation

*Dual rated heaters will draw 13% less amps and 25% less wattage when operated at 208V. *2-Stage heating standard.

Electronic Unit Heater KB Platinum Series

Field Mount Options

ADD SUFFIX:	UPC	DESCRIPTION
DS32	13480	Disconnect Switch, Field Installed Kit, 32 AMP, 600V
DS63	13481	Disconnect Switch, Field Installed Kit, 63 AMP, 600V
DS80	13482	Disconnect Switch, Field Installed Kit, 80 AMP, 600V
DS100	13483	Disconnect Switch, Field Installed Kit, 100 AMP, 600V

Replacement Accessories

MODEL	UPC	DESCRIPTION	WT. (lbs.)
KBB-1	13484	Replacement Universal Wall/Ceiling Small Mounting Bracket (for heaters with size A heaters)	1.9
KBB-2	13485	Replacement Universal Wall/Ceiling Large Mounting Bracket (for heaters with size B and C)	2.6
KBB-3	13488	Replacement Universal Wall/Ceiling Large Mounting Bracket (for heaters with size F & G)	3.9
KBHS	13486	Replacement Hook Swivel	0.4
KBHK	13487	Replacement Hardware Kit	0.1
61747	61747	Platinum Replacement Infrared Remote Control	0.1

Bracket Selection Chart

BRACKET #	HEATER KW SIZE USED WITH	BRACKET DIMENSIONS											
		L	W	H	A	B	C	D	E	F	X	Y	Z
KBB-1	3 to 5 kW (1 phase)	12½"	215/16"	101/16"	13/16"	7"	17/8"	17/8"	9¼"	17/8"	¾"	1"	½"
KBB-2	7.5 to 10 kW (1 phase) 3 to 20 kW (3 phase)	167/8"	215/16"	101/8"	1¼"	7"	17/8"	15/8"	135/8"	15/8"	¾"	1"	1½"
KBB-3	25 to 40 kW (3 phase)	19½"	43/16"	133/16"	15/16"	10"	17/8"	15/8"	16¼"	11/8"	11/16"	1"	2"

Dimensional Data

Twin Unit Size F & G

HEATER SIZE	HEIGHT	DEPTH	WIDTH
A	16.5"	11"	15"
B	16.5"	13.5"	15"
C	16.5"	18"	15"
E	20.5"	18"	15"
F	18.5"	18"	30"
G	20.5"	18"	30"

KBB-1, KBB-2 & KBB-3
Unit heater brackets can be used for mounting on ceiling or wall. 3/8" threaded hole on top of unit heater can also be used with threaded rod to drop the unit closer to the floor. Refer to bracket selection chart.

Stainless Steel Unit Heater KBS Series



Model Code:

KBS	48	10	-1
A	B	C	D

A: Series
 B: 20 - 208V, 24 - 240V
 27 - 277V, 48 - 480V
 C: KiloWatts
 D: -1 Phase, -3 Phase



- 18 gauge stainless steel case
- Adjustable discharge louvers
- Auto-reset limit
- Long life unit bearing motor
- Padlock disconnect
- Spiral finned element
- Totally enclosed motor
- Pilot light
- Aluminum fan blade
- N.E.M.A. 4 enclosure
- 2-year limited warranty

The KBS Stainless Steel Unit Heater

KBS unit heaters are specially constructed for heating of, and freeze protection in, dirty, dusty or corrosive areas requiring periodic washing or hose-down. Typical places of use are: waste water treatment plants, car/truck washes, cement plants, steel mills or such, canneries and dairy facilities, ship and marine docks, fish processors and load banks for generators. The heater is constructed from 18-gauge type 304 Stainless Steel and elements making it extremely corrosion resistant. The N.E.M.A. 4 wiring compartment is sealed and gasketed making it water tight. All optional control components are U.L. listed for use in N.E.M.A. 4 enclosures.

Factory Installed Options

- Fan Delay:** Standard above 11kW
- Power Contactor:** (when not standard)
- 24 Volt Control:** (when not standard)

Mounting: Universal mounting bracket made from Stainless Steel included.

NEMA 4 Control Options:

- SPST thermostat
- Two stage thermostat (single phase only)
- Summer fan switch
- Pilot light (power on indicator)
- Padlock disconnect

Engineering Specifications

Contractor shall supply and install KBS Series Stainless Steel heaters, manufactured by King Electrical Mfg. Company. Heaters shall be of the wattage and voltage as indicated on the plans.

Stainless Steel Construction: All exterior and interior metal enclosure parts are made from 18 gauge type 304 Stainless Steel. All fasteners and hardware are Stainless Steel.

Adjustable Outlet Louver: Stainless Steel louvers direct air up or down as needed for the heating application.

Rear Intake Screen: Heavy gauge Stainless Steel screen protects against foreign objects making accidental contact with the rotating fan blade.

N.E.M.A. 4 Enclosure: Every electrical component in the wiring compartment is sealed with a polyurethane adhesive. The bottom access panel is sealed with a 1/4" high density polyurethane gasket. This provides excellent protection against corrosion, windblown dust, dirt, and rain, splashing water and hose-directed water. All optional control accessories are N.E.M.A. 4 rated.

Stainless Steel Spiral Fin Elements: The metal sheath element is brazed with spiral fins then molded in to a coil configuration. This combination produces the best heat transfer while eliminating the potential for hot spots by positioning the element in the maximum air flow stream. Stainless steel increases element life in extremely corrosive environments such as waste water treatment plants.

Totally Enclosed Fan Motor: Permanently lubricated, long life unit bearing coated motor with enclosed rotor resists moisture and corrosion for long-lasting, trouble-free operation.

Aluminum Fan Blade: Axial flow-type mounted directly to the motor shaft for maximum efficiency.

Manual Reset Limit Electrically Held: Power is disconnected from the heater if an overheated condition occurs. The heater is re-energized automatically when the normal operating temperature returns.

Internal Controls: Magnetic contactors are standard on all 480V heaters, all 208V/1-Phase, 240V/1-Phase, 277V/1-Phase heaters above 5kW, and all 3-Phase heaters. The control voltage is equal to the line voltage (208, 240 or 277) except for 480V models where a transformer is provided for 24V control. Over 5kW the line voltage control is operating the contactor coil only and will draw only 1 Amp.

Fusing: Internal circuit fusing is provided when the heater ampacity exceeds 48 Amps to comply with UL standards. A fan delay is provided standard on models 12.5-kW and above to dissipate residual heat from the heating elements.

Approvals: cULus

*Dimensions

SIZE	HEIGHT	DEPTH	WIDTH
A	16.5"	11"	15"
B	16.5"	13.5"	15"
C	16.5"	18"	15"
E	20.5"	18"	15"

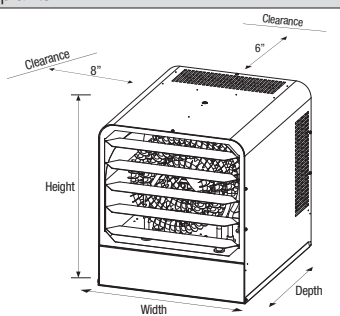

Accessories

MODEL	DESCRIPTION	UPC#	WT. (lbs)
KBB-1-SS	Mounting Bracket - Small	15254	3
KBB-2-SS	Mounting Bracket - Large	15256	4
TF115	Single Pole Wall Mount Thermostat N.E.M.A. 4X - 25A SPDT	19150	1

Stainless Steel Unit Heater KBS Series

Ordering Information

MODEL	UPC	KW	BTUH	PHASE	VOLTS	AMPS	**THERM. CONTROL VOLTAGE	MOTOR HP	CFM	TEMP. RISE	AIR THROW	MAX. MOUNT HEIGHT	*SIZE	WT. (lbs.)
KBS2003-1-B1	22118	3	10.2	1	208	14.4	208	9W	400	40°	16ft.	8ft.	A	30.5
KBS2403-1-B1	22217	3	10.2	1	240	12.5	240	9W	400	40°	16ft.	8ft.	A	30.5
KBS2703-1-B1	22218	3	10.2	1	277	10.8	277	9W	400	40°	16ft.	8ft.	A	30.5
KBS2005-1-B1	22124	5	17	1	208	24	208	9W	400	40°	16ft.	8ft.	A	30.5
KBS2405-1-B1	20847	5	17	1	240/208*	20.8/18	240	9W	400	40°	16ft.	8ft.	A	30.5
KBS2705-1-B1	22127	5	17	1	277	18.1	277	9W	400	40°	16ft.	8ft.	A	30.5
KBS4805-1-B1	22128	5	17	1	480	10.4	24	9W	400	40°	16ft.	8ft.	A	30.5
KBS2007-1-B1	22133	7.5	25.6	1	208	36.1	208	16W	600	40°	20ft.	9ft.	B	45.0
KBS2407-1-B1	22137	7.5	25.6	1	240/208*	31.2/27	240	16W	600	40°	20ft.	9ft.	B	45.0
KBS2707-1-B1	22219	7.5	25.6	1	277	27	277	16W	600	40°	20ft.	9ft.	B	45.0
KBS4807-1-B1	22142	7.5	25.6	1	480	15.6	24	16W	600	40°	20ft.	9ft.	B	45.0
KBS2010-1-B2	22147	10	34.1	1	208	48.1	208	25W	725	44°	24ft.	10ft.	B	45.0
KBS2410-1-B2	22151	10	34.1	1	240/208*	41.6/36.1	240	25W	725	44°	24ft.	10ft.	B	45.0
KBS2710-1-B2	22154	10	34.1	1	277	36.1	277	25W	725	44°	24ft.	10ft.	B	45.0
KBS4810-1-B2	22155	10	34.1	1	480	20.8	24	25W	725	44°	24ft.	10ft.	B	45.0
KBS2012-1-B2	22159	12.5	42.7	1	208	60.1	208	35W	825	48°	30ft.	11ft.	C	46.5
KBS2412-1-B2	22163	12.5	42.7	1	240/208*	52/45.1	240	35W	825	48°	30ft.	11ft.	C	46.5
KBS2020-3-B2	22173	20	68.3	3	208	55.5	208	50W	1100	57°	47ft.	13ft.	C	46.5
KBS2420-3-B2	20849	20	68.3	3	240/208*	48.1/41.6	240	50W	1100	57°	47ft.	13ft.	C	46.5
KBS2403-3MP-B2	22222	3	10.2	1-3	240/208*	12.5/7.2	240	9W	400	40°	16ft.	8ft.	C	46.5
KBS4803-3MP-B2	22120	3	10.2	1-3	480	6.3	24	9W	400	40°	16ft.	8ft.	C	46.5
KBS2005-3MP-B2	22126	5	17.1	1-3	208	24 & 13.9	208	9W	400	40°	16ft.	8ft.	C	46.5
KBS2405-3MP-B2	22223	5	17.1	1-3	240/208*	20.8/18 & 18/15.6	240	9W	400	40°	16ft.	8ft.	C	46.5
KBS4805-3MP-B2	20850	5	17.1	1-3	480	10.4 & 6	24	9W	400	40°	16ft.	8ft.	C	46.5
KBS2007-3MP-B2	22135	7.5	25.6	1-3	208	36.1 & 20.8	208	16W	600	40°	20ft.	9ft.	C	46.5
KBS2407-3MP-B2	22139	7.5	25.6	1-3	240/208*	31.2/27 & 18/15.6	240	16W	600	40°	20ft.	9ft.	C	46.5
KBS4807-3MP-B2	20717	7.5	25.6	1-3	480	15.6 & 24	24	16W	600	40°	20ft.	9ft.	C	46.5
KBS2010-3MP-B2	22149	10	34.1	1-3	208	27.7	208	25W	725	44°	24ft.	10ft.	C	46.5
KBS2410-3MP-B2	20848	10	34.1	1-3	240/208*	41.6/36.1 & 24/20.8	240	25W	725	44°	24ft.	10ft.	C	46.5
KBS4810-3MP-B2	20851	10	34.1	1-3	480	20.8 & 12	24	25W	725	44°	24ft.	10ft.	C	46.5
KBS2012-3-B2	22161	12.5	42.7	3	208	34.6	208	35W	825	48°	30ft.	11ft.	C	46.5
KBS2412-3-B2	22164	12.5	42.7	3	240/208*	30/26	240	35W	825	48°	30ft.	11ft.	C	46.5
KBS4812-3MP-B2	22166	12.5	42.7	1-3	480	26 & 15	24	35W	825	48°	30ft.	11ft.	C	46.5
KBS2015-3-B2	22169	15	51.2	3	208	41.6	208	35W	925	51°	33ft.	12ft.	C	46.5
KBS2415-3-B2	22171	15	51.2	3	240/208*	36/31.2	240	35W	925	51°	33ft.	12ft.	C	46.5
KBS4815-3MP-B2	22224	15	51.2	1-3	480	18	24	35W	925	51°	33ft.	12ft.	C	46.5
KBS4820-3MP-B2	20852	20	68.3	1-3	480	41.6/24.1	24	50W	1100	57°	37 ft.	12ft.	E	55.0

*Dual rated heaters will draw 13% less amps and 25% less wattage when operated at 208V.

Options

SUFFIX	DESCRIPTION
-T	1-Pole Unit Mounted Thermostat (temperature range 40°F - 100°F)
-2TS	2-Stage Thermostat (Single Phase models only)
-B1	Mounting Bracket KBB-1 (included with heater size A)
-B2	Mounting Bracket KBB-2 (included with heater size B and C)
-SF	Summer Fan Switch
-SFR	Control Relay and 24V Transformer for Remote Summer Fan Operation
-PL	Pilot Light (power ON indication)

Options

SUFFIX	DESCRIPTION
-CX	Power Contactor for 3 kW - 5kW 1-Phase Models (Line Voltage Coil)
-CT24	Transformer that Converts 208, 240 and 277 Volts to 24 Volt Control Circuit (add power contactor (-CX) for 3 kW-5kW 1-Phase models)
-DS32	Disconnect Switch, Field Installed Kit, 32 AMP, 600V
-DS63	Disconnect Switch, Field Installed Kit, 63 AMP, 600V
-DS80	Disconnect Switch, Field Installed Kit, 80 AMP, 600V
-DS100	Disconnect Switch, Field Installed Kit, 100 AMP, 600V

High Air Velocity Unit Heater KFUH Series



Model Code:

KFUH	48	10	-3
A	B	C	D
A: Series			
B: 20 - 208V 24 - 240V 48 - 480V			
C: Kilowatts			
D: 1 or 3-phase			



Shown with KFUH DIFFUSER.
KFUH DIFFUSER required for
this heater and is sold separately

- Heavy duty open coil element
- Adjustable louver hood (sold separately)
- Can be ducted on intake and outlet
- Direct drive air over type motor
- 22 gauge steel
- 24 Volt control
- Dual inlet industrial blower
- Quiet switching relays
- Fan-only relay
- Horizontal or Vertical Mount
- Replaceable intake filter
- ECM Motor (optional)
- 5-year limited warranty



The KFUH High Air Velocity Unit Heater

The KFUH series commercial unit heater is an efficient, dependable unit heater perfectly suited for high ceiling applications such as warehouses, parking garages and docks. The 3-speed, high-capacity motor and blower quietly delivers large volumes of air ranging from 775 to 1540 CFM minimum. With welded mounting channels on the unit, the heater may be mounted at any angle. Safety screens are provided at both the air intake and discharge aperture. The intake filter is replaceable. Thermostat may be ordered separately.

FIELD WIRING: 208 and 240 volt unit heaters are equipped with circuit breakers to provide internal circuit protection when heater exceeds 48 amps. 480 Volt unit heaters do not have circuit breakers but are fused when internal protection is required over 48 Amps. Terminal blocks are supplied for field wiring on all units. Consult the National Electric Code for proper wire size and service circuit breaker protection.

CONTROL WIRING: Connect low voltage thermostat to terminals R and W on the low voltage terminal block. For fan only operation connect terminals R and G with a switch or thermostat fan switch.

Unit shown with standard diffuser model # KFUH DIFFUSER ordered separately. Additional diffusers are located on the 3rd page of this specification sheet.

Engineering Specifications

Contractor shall supply and install KFUH Series unit heaters manufactured by King Electrical Mfg. Company. Heaters shall be of the wattage and voltage as indicated on the plans.

Transformer: Each unit is equipped with a heavy duty low voltage (24 Volt) transformer for the thermostat control circuit.

Heating Elements: Quick heating, long life Ni-Chrome elements are sized to provide proper watt density for maximum heat dissipation by fan-forced air convection currents.

Terminal Block: For single strike field wiring.

Low Voltage Terminal Block: For 24 Volt control.

Air Filter: Convenient access for replacement of standard 16" x 20" x 1" filter.

Motor: Long life, 48 frame capacitor run, thermally protected, permanently lubricated, direct drive motor (no belts to adjust or slip). This low noise, up to 3-speed motor is designed for maintenance-free operation.

Overcurrent Protection: 208 and 240 volt KFUH models have 60 amp circuit breakers with single strike terminal block. 480 volt models have single strike terminal block. Units over 48 amps have 60 amp fusing.

Limit Control: Integral automatic high temperature limit control in each heating element bank prevents the delivery of air at unsafe temperatures. 20-35 kW use a manual reset limit control to completely shut the unit heater off should overtemperature occur.

Fan Relay: Heavy duty fan relay standard with summer fan operation.

Approvals: UL (E41422)

High Air Velocity Unit Heater KFUH Series

Ordering Information

MODEL	VOLTS	kilo watts	BTUH	AMPS	# of ELEMENTS	MOTOR HP	TEMPERATURE RISE (° F)			SIZE	WT. (lbs)
							LOW	MED	HIGH		
KFUH2003-1	208	3	10.2	14.4	1	1/5	12°	11°	9°	Fig. A	57
KFUH2404-1	240	4	13.6	16.7	1	1/5	16°	15°	13°	Fig. A	57
KFUH2005-1	208	5	17.1	24	1	1/5	20°	18°	16°	Fig. A	57
KFUH2405-1	240	5	17.1	20.8	1	1/5	20°	18°	16°	Fig. A	57
KFUH4805-1	480	5	17.1	10.4	1	1/5	20°	18°	16°	Fig. A	57
KFUH2006-1	208	6	20.5	25	2	1/5	24°	22°	19°	Fig. A	57
KFUH2408-1	240	8	26.9	33.3	2	1/5	33°	29°	25°	Fig. A	65
KFUH2010-1	208	10	34.1	48	2	1/5	41°	37°	32°	Fig. A	65
KFUH2410-1	240	10	34.1	41.7	2	1/5	41°	37°	32°	Fig. A	65
KFUH4810-1	480	10	34.1	20.8	2	1/5	41°	37°	32°	Fig. A	65
KFUH2412-1	240	11.5	39.2	47.9	2	1/5	47°	42°	36°	Fig. A	65
KFUH4812-1	480	11.5	39.2	23.9	2	1/5	47°	42°	36°	Fig. A	65
KFUH2015-1	208	15	51.2	72.1	3	1/5	61°	55°	47°	Fig. A	74
KFUH2415-1	240	15	51.2	62.5	3	1/5	61°	55°	47°	Fig. A	74
KFUH4815-1	480	15	51.2	31.2	3	1/5	61°	55°	47°	Fig. A	74
KFUH2418-1	240	17.25	58.8	82.9	3	1/5	70°	63°	55°	Fig. A	74
KFUH4818-1	480	17.25	58.8	35.9	3	1/5	70°	63°	55°	Fig. A	74
KFUH2020-1	208	20	68.3	96.2	4	1/3	57°	51°	41°	Fig. B	76
KFUH2420-1	240	20	68.3	83.3	4	1/3	57°	51°	41°	Fig. B	76
KFUH4820-1	480	20	68.3	41.7	4	1/3	57°	51°	41°	Fig. B	76
KFUH2025-1	208	25	85.3	120.2	5	1/3	72°	63°	51°	Fig. B	81
KFUH2425-1	240	25	85.3	104.2	5	1/3	72°	63°	51°	Fig. B	81
KFUH4825-1	480	25	85.3	52.1	5	1/3	72°	63°	51°	Fig. B	81
KFUH2030-1	208	30	102.4	144.2	6	1/3	86°	76°	62°	Fig. B	85
KFUH2430-1	240	30	102.4	125	6	1/3	86°	76°	62°	Fig. B	85
KFUH4830-1	480	30	102.4	62.5	6	1/3	86°	76°	62°	Fig. B	85
KFUH2435-1	240	34.5	117.7	143.7	6	1/3	99°	87°	71°	Fig. B	85
KFUH4835-1	480	34.5	117.7	71.8	6	1/3	99°	87°	71°	Fig. B	85

MODEL	VOLTS	kilo watts	BTUH	AMPS	# of ELEMENTS	MOTOR HP	TEMPERATURE RISE (° F)			SIZE	WT. (lbs)
							LOW	MED	HIGH		
KFUH2405-3	240	5	17.1	13	3	1/5	30°	25°	20°	Fig. A	74
KFUH4805-3	480	5	17.1	7	3	1/5	30°	25°	20°	Fig. A	74
KFUH2009-3	208	9	30.7	21.6	3	1/5	37°	33°	28°	Fig. A	74
KFUH2410-3	240	10	34.1	24.1	3	1/5	41°	37°	32°	Fig. A	74
KFUH4810-3	480	10	34.1	12	3	1/5	41°	37°	32°	Fig. A	74
KFUH2012-3	208	11.25	38.4	31.2	3	1/5	46°	41°	35°	Fig. A	74
KFUH2412-3	240	12	40.9	28.9	3	1/5	49°	44°	38°	Fig. A	74
KFUH4812-3	480	12	40.9	14.4	3	1/5	49°	44°	38°	Fig. A	74
KFUH2015-3	208	15	51.2	41.6	3	1/5	61°	55°	47°	Fig. A	74
KFUH2415-3	240	15	51.2	36.1	3	1/5	61°	55°	47°	Fig. A	74
KFUH4815-3	480	15	51.2	18.1	3	1/5	61°	55°	47°	Fig. A	74
KFUH2418-3	240	17.25	58.8	43.3	3	1/5	70°	63°	55°	Fig. A	74
KFUH4818-3	480	17.25	58.8	20.7	3	1/5	70°	63°	55°	Fig. A	74
KFUH2420-3	240	20	68.3	48	4	1/5	57°	51°	41°	Fig. B	85
KFUH4820-3	480	20	68.3	24	4	1/5	57°	51°	41°	Fig. B	85
KFUH2022-3	208	22.5	76.8	62.5	6	1/3	64°	56°	46°	Fig. B	85
KFUH2424-3	240	24	81.6	57.7	6	1/3	69°	61°	49°	Fig. B	85
KFUH4824-3	480	24	81.6	28.8	6	1/3	69°	61°	49°	Fig. B	85
KFUH2030-3	208	30	102.4	83.3	6	1/3	86°	76°	62°	Fig. B	85
KFUH2430-3	240	30	102.4	72.2	6	1/3	86°	76°	62°	Fig. B	85
KFUH4830-3	480	30	102.4	36.1	6	1/3	86°	76°	62°	Fig. B	85
KFUH2435-3	240	34.5	117.7	82.9	6	1/3	99°	87°	71°	Fig. B	85
KFUH4835-3	480	34.5	117.7	41.5	6	1/3	99°	87°	71°	Fig. B	85

High Air Velocity Unit Heater KFUH Series

Dimensional Data

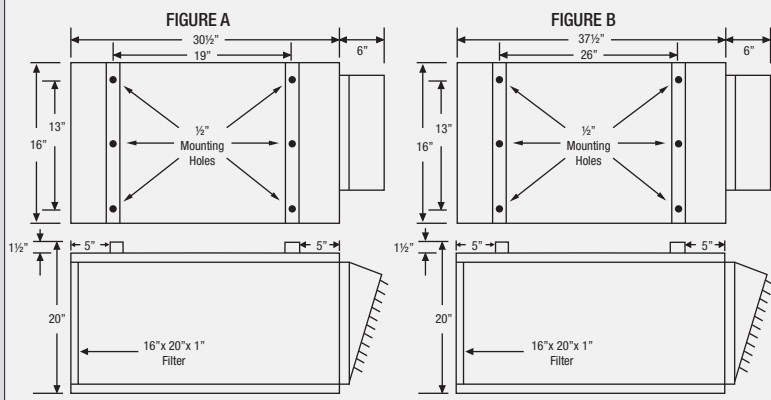

Dual Mounting

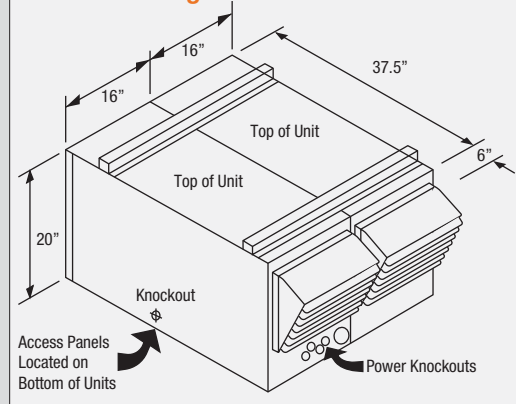

Mounting

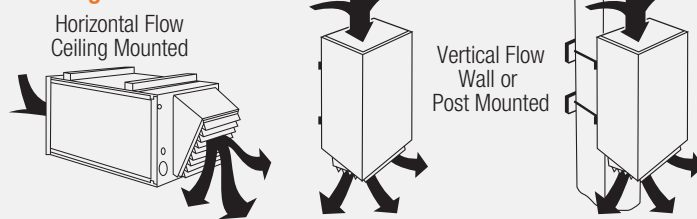

Diffusers



KFUH-90RD



KFUH-90D

Options

ADD SUFFIX:	DESCRIPTION
-2S1	2 Stage Control 1-Phase models
-2S3	2 Stage Control 3-Phase models (5 kW increments only)
-DS40	40 Amp, 3-Pole Non-Fused Locking Disconnect Switch
-DS60	60 Amp, 3-Pole Non-Fused Locking Disconnect Switch
-DS80	80 Amp, 3-Pole Non-Fused Locking Disconnect Switch
-DS100	100 Amp, 3-Pole Non-Fused Locking Disconnect Switch
-T	1-Pole Thermostat

Air Flow Delivery Chart

MOTOR HP	MOTOR SPEED			LOW		MED		HIGH	
	VOLTS	AMPS		CFM	FPM	CFM	FPM	CFM	FPM
1/5	230 ³	3.4		775	570	860	630	1000 ¹	735
	380 / 460 ¹	1.7							
1/3	230 ³	3.2		1100 ²	810	1250	920	1540 ²	1130
	380 / 460 ²	1.7							
1/2	230 ³	3.8		1250	920	1540	1130	1750 ³	1285
	380 / 460 ¹	1.9							
Motor Wire Color				RED		BLUE		BLACK	

*Air Volume=Ft.³ Per Minute (CFM) *Air Velocity=Ft. Per Minute (FPM)

¹Single speed (high), ²Two speed (High/Low), ³Three speed (Low/Med/High)

KFUH Diffuser Options

MODEL	UPC	DESCRIPTION	WEIGHT (lbs.)
KFUH-DIFFUSER	15741	Standard KFUH Air Diffuser	5.0
KFUH-ND	15725	No Diffuser, 1" duct collar only discharge side for connection to 14" x 14" duct	N/A
KFUH-RD	15743	Radial diffuser for wide pattern heat dispersion	4.0
KFUH-90D	15728	Right angle elbow (90°) diffuser with adjustable louvers	15.0
KFUH-90RD	15729	Right angle elbow (90°) with radial diffuser	14.0

KFUH Factory Installed Options

MODEL	UPC	DESCRIPTION	WEIGHT (lbs.)
KFUH-1/3HP	NA	Upgrade to 1/3 HP Motor & Blower for 3-18KW units	N/A
KFUH-1/2HP	NA	Upgrade to 1/2 HP Motor & Blower for 20-35KW units	N/A
KFUH-ECM	NA	Upgrade to ECM Motor 1/3 HP	N/A
KFUH-T	15747	Factory Installed Stat (SPST). Temperature range 40°F to 100°F	N/A
KFUH-2TS	15707	Factory Installed Stat (DPST). Temperature range 40°F to 100°F	N/A
KFUH-SF	15708	Factory Installed Summer Fan Switch	N/A
KFUH-2S1	15714	Control Relays & Contactor for 2-Stage Element Control, 1-Phase heaters. Available on certain models.	N/A
KFUH-2S3	15716	Control Relays & Contactor for 2-Stage Element Control, 3-Phase heaters. Available on certain models.	N/A
K-DS40	NA	Factory Installed 40 Amp, 3-Pole Non-Fused Locking Disconnect Switch	N/A
K-DS60	NA	Factory Installed 60 Amp, 3-Pole Non-Fused Locking Disconnect Switch	NA
K-DS80	NA	Factory Installed 80 Amp, 3-Pole Non-Fused Locking Disconnect Switch	N/A
K-DS100	NA	Factory Installed 100 Amp, 3-Pole Non-Fused Locking Disconnect Switch	N/A
1E30-910	19000	Wall mount thermostat, 24V, range 50° - 90°	1.0
KFUH-PTBL	17216	Kit to make KFUH Portable. Includes casters and mounting bracket (No Cord)	N/A

Plenum Rated Unit Heater CK Series



Model Code:

CK	48	10	-3
A	B	C	D

A: Series
 B: 20 - 208V 24 - 240V
 48 - 480V
 C: Kilowatts
 D: 1 or 3-phase



- Spiral finned element
- Dual inlet blower
- Totally enclosed motor
- N.E.M.A. 12 construction
- Adjustable louver hood
- Available in 208, 240 & 480 volt
- 18GA steel enclosure
- 24V control
- Horizontal/Vertical mount
- Can be ducted
- Fan only relay
- 3-year limited warranty



Concealed Space Use - Zero Clearance

The CK model is a special application heater approved for use in concealed areas of buildings such as an area between a finished ceiling and drop ceiling, in an open plenum or in a ducted system. It is specifically designed for high-rise and office buildings, factories, auto body shops, food processing plants, plating shops, and machine shops. It is engineered to withstand dirty, dusty, moist or even mildly corrosive environments, and rated for zero clearance mounting against any surface.

Not intended for use where flammable vapors, gases, liquids or other combustibles are, or may be present.

Factory Installed Options

Thermostat: A N.E.M.A. 4X thermostat.

120 Volt Control: Control components modified to accept 120V control. A circuit outboard supply is customer provided.

Element Step Control: 2-Stage control. For improved energy management additional steps can be added (refer to table).

Disconnect Switch: Available with a 3-Pole non-fused disconnect with a padlock provision.

Motor HP Upgrades: Standard models are listed with motors that will provide sufficient CFM for the kW they are designed for. Where additional CFM is required a larger motor and blower can be provided.

No Diffuser: Used when heater will be connected to ductwork or use an alternate diffuser.

Remote Fuse Panel: Available when heater is mounted in an inaccessible area allowing fuses to be located in an electrical closet where they can be easily serviced.

Engineering Specifications

Contractor shall supply and install CK Series plenum heaters manufactured by King Electrical Mfg. Company.

Heaters shall be of the wattage and voltage as indicated on the plans.

Construction: The heater case is fabricated from high tensile 18 gauge electrogalvanized steel that is welded together forming a durable unibody cabinet. Heater is finished with a rust inhibiting epoxy coating.

Adjustable Outlet Louver: Louvers direct air up or down as needed for the heating application.

Intake and Discharge Screen: Heavy gauge steel screen protects against foreign objects entering the heater. A 1" x 16" x 20" filter is provided to prevent dirt and dust build up in the heater.

Air Filter: Convenient access for replacement of standard 16" x 20" x 1" filter.

N.E.M.A. 12 Wiring Compartment: The wiring compartment is sealed with a ¼" high density polyurethane gasket. This provides excellent protection against moisture, dust and dirt from invading the electrical components and wiring. All optional control accessories are N.E.M.A. 12 rated.

Spiral Fin Elements: The metal sheath element is brazed with spiral fins and then formed into a coil configuration. This combination produces the best heat transfer while eliminating the potential for hot spots by positioning the element in the maximum airflow stream.

Blower & Motor: Totally enclosed outdoor ball bearing fan motor. Permanently lubricated, class B insulation, auto-protected, permanent split capacitor and 60°C ambient. Large capacity dual-inlet blower handles high static pressure and moves large air volume. Motor leads are enclosed

in a sealrite raceway to prolong equipment life & reduce maintenance.

Air Intake Temperature Control: A built-in thermostat located at the intake blower is factory set at 100°F which prevents the heater from operating when the ambient temperature exceeds this limit. This will prevent the heater from wasting energy and is an extra measure of safety.

Auto-Reset Thermal Cutout: Power is disconnected from the element if an overheated condition occurs. The fan continues to run to dissipate excess heat from the element. The element is re-energized automatically when the normal operating temperature returns.

Internal Controls: Magnetic contactors are standard on all units. A transformer is provided for 24 Volt control. This enables the customer to use a standard low voltage thermostat. Subcircuit fusing is provided when the heater ampacity exceeds 48 Amps to comply with UL standards. A fan delay is provided standard on models above 11kW to dissipate residual heat from the heating elements.

Easy Wiring: large wiring compartment allows quick access
Mounting: CK heater comes with two brackets welded on top to be hung from the ceiling or beam using threaded rod.

Approvals: ETL Certified to comply with standard for Heating and Cooling Equipment ANSI/UL 1995 fourth edition. Meets stringent City of Chicago codes for plenum use.

Plenum Rated Unit Heater CK Series

Dimensional Data

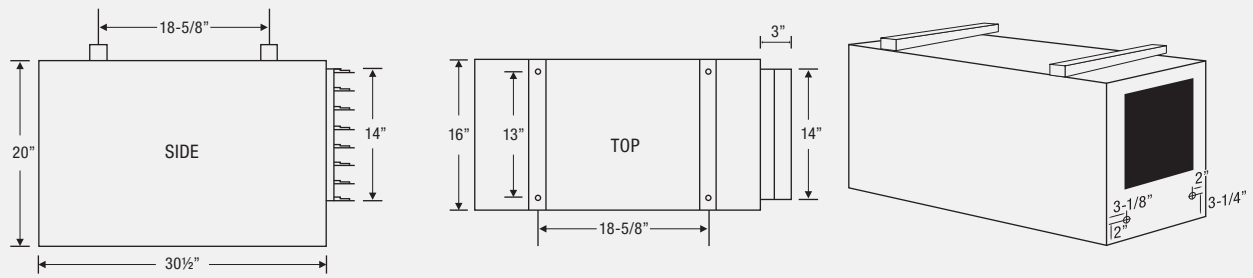

Ordering Information *Suffix -1 = single phase & Suffix -3 = 3 phase

	MODEL	KILOWATTS	BTUH(000)	VOLTS	AMPS	MOTOR HP	CFM	TEMP. RISE °F	WEIGHT lbs
	CK2003-1	3.3	10	208	14.4	N/A	600	17.4°	75
	CK2005-1	5	17	208	24	N/A	600	26.3°	75
	CK2007-1	7.5	23.9	208	33.6	1/4	1000	23.7°	80
	CK2010-1	10	34.1	208	48.1	1/4	1000	31.6°	80
	CK2012-1	12.5	41	208	57.7	1/4	1000	39.5°	85
	CK2015-1	15	51.2	208	72.1	1/4	1000	47.4°	85
208V	CK2003-3	3	10	208	8.3	N/A	600	17.4°	90
	CK2005-3	5	17.1	208	13.8	N/A	600	26.3°	90
	CK2007-3	7.5	23.9	208	19.5	1/4	1000	23.7°	90
	CK2010-3	10	34.1	208	27.8	1/4	1000	31.6°	90
	CK2012-3	12.5	41	208	33.3	1/4	1000	39.5°	90
	CK2015-3	15	51.2	208	41.6	1/4	1000	47.4°	90
	CK2020-3	20	68.3	208	55.5	1/2	1250	50.6°	95
	CK2025-3	25	85.3	208	69.4	1/2	1250	63.2°	95
	CK2030-3	30	102.4	208	83.3	1/2	1500	63.2°	100
		CK2403-1	3.3	10	240	12.5	N/A	600	17.4°
	CK2405-1	5	17	240	20.8	N/A	600	26.3°	75
	CK2407-1	7.5	23.9	240	29.2	1/4	1000	23.7°	80
	CK2410-1	10	34.1	240	41.7	1/4	1000	31.6°	80
	CK2412-1	12.5	41	240	50	1/4	1000	39.5°	85
	CK2415-1	15	51.2	240	62.5	1/4	1000	47.4°	85
240V	CK2403-3	3	10	240	7.2	N/A	600	17.4°	90
	CK2405-3	5	17.1	240	12.1	N/A	600	26.3°	90
	CK2407-3	7.5	23.9	240	16.9	1/4	1000	23.7°	90
	CK2410-3	10	34.1	240	24.1	1/4	1000	31.6°	90
	CK2412-3	12.5	41	240	28.9	1/4	1000	39.5°	90
	CK2415-3	15	51.2	240	36.1	1/4	1000	47.4°	90
	CK2420-3	20	68.3	240	48.1	1/2	1250	50.6°	95
	CK2425-3	25	85.3	240	60.1	1/2	1250	63.2°	95
	CK2430-3	30	102.4	240	72.2	1/2	1500	63.2°	100
	CK2433-3	33	112.6	240	79.5	1/2	1500	84.3°	120
	CK4805-1	5	17	480	10.4	1/4	1000	15.8°	75
	CK4807-1	7.5	23.9	480	14.6	1/4	1000	23.7°	80
	CK4810-1	10	34.1	480	20.8	1/4	1000	31.6°	80
	CK4812-1	12.5	41	480	25	1/4	1000	39.5°	85
	CK4815-1	15	51.2	480	31.1	1/4	1000	47.4°	85
480V	CK4805-3	5	17.1	480	6	1/4	1000	15.8°	90
	CK4807-3	7.5	23.9	480	8.4	1/4	1000	23.7°	90
	CK4810-3	10	34.1	480	12	1/4	1000	31.6°	90
	CK4812-3	12.5	41	480	14.5	1/4	1000	39.5°	90
	CK4815-3	15	51.2	480	18	1/4	1000	47.4°	90
	CK4820-3	20	68.3	480	24.1	1/2	1250	50.6°	95
	CK4825-3	25	85.3	480	30.1	1/2	1250	63.2°	95
	CK4830-3	30	102.4	480	36.1	1/2	1500	63.2°	100
	CK4833-3	33	112.6	480	39.7	1/2	1500	84.3°	120

Plenum Rated Unit Heater CK Series

Internal View

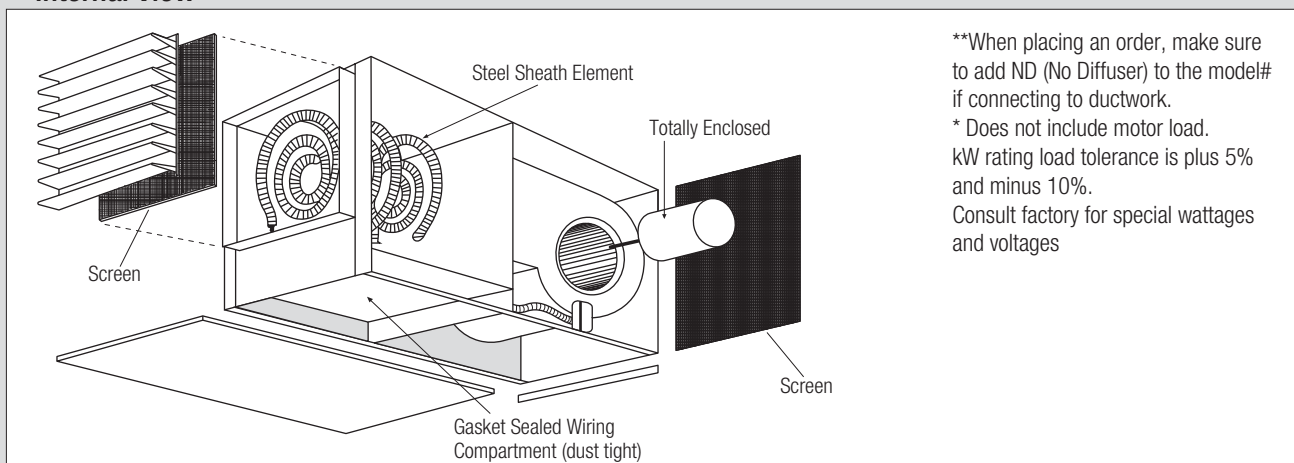

**When placing an order, make sure to add ND (No Diffuser) to the model# if connecting to ductwork.
 * Does not include motor load.
 kW rating load tolerance is plus 5% and minus 10%.
 Consult factory for special wattages and voltages

Installation Options

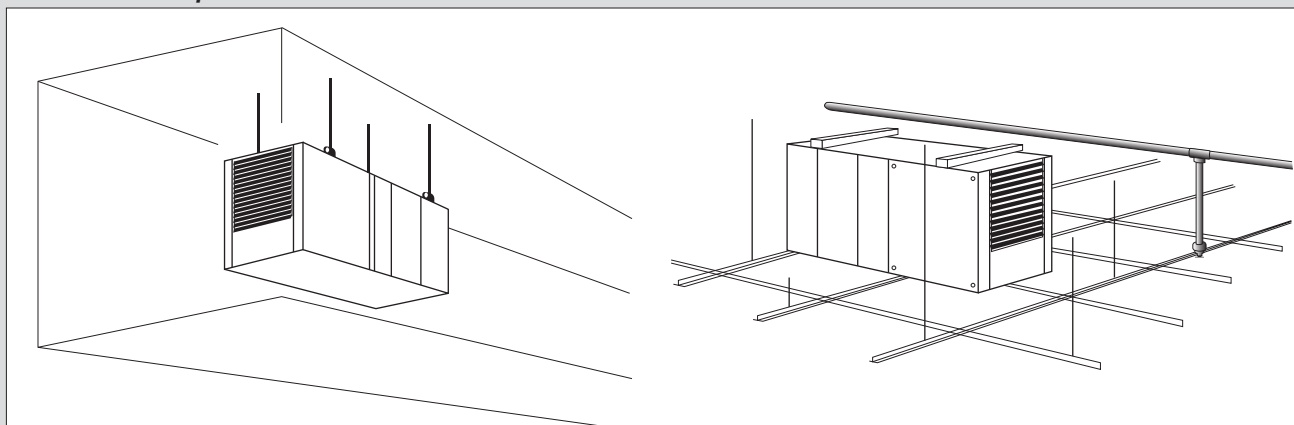

- CK Heater installed inside a plenum area for inline ducted air and heat boost in large commercial HVAC systems
- CK Model for heating large HVAC air intake systems. Provides pre-heating for controlled HVAC multiple floor supply systems in high rise buildings. Ducted heated air supply for garage ventilation systems.
- CK Heater installed above a ceiling in a concealed area. Heaters provide constant temperature control and act as freeze safety for sprinkler systems in concealed areas.

Options

ADD SUFFIX	DESCRIPTION
-T	NEMA 4X Single Pole Thermostat
-C120	120V Control
-1/4HP	Substitute 1/4 HP Motor (1000 CFM)
-1/3HP	Substitute 1/3 HP Motor (1250 CFM)
-1/2HP	Substitute 1/2 HP Motor (1500 CFM)
-3/4HP	Substitute 3/4 HP Motor (2000 CFM)
-DS40	40 Amp 3-Pole Lockable Disconnect Switch

ADD SUFFIX	DESCRIPTION
-DS60	60 Amp 3-Pole Lockable Disconnect Switch
-DS80	80 Amp 3-Pole Lockable Disconnect Switch
-DS100	100 Amp 3-Pole Disconnect Switch
-SSR25	Solid State Relays (25 Amp Maximum) with 0-10V SCR
-SSR45	Solid State Relays (45 Amp Maximum)
-C1025	Modulating Thermostat for SSR Control
-220068	Duct Sensor for Modulating Thermostat
-ND	NO DIFFUSER

Large Plenum Rated Heater CKL Series



Model Code:

CKL	48	24	3	8	10
A	B	C	D	E	F

A: Series

B: 20 - 208V 24 - 240V
48 - 480V

C: Kilowatts

D: 1 or 3-phase

E: Stages

F: CFM



- Spiral finned element
- Dual inlet blower
- Totally enclosed motor
- N.E.M.A. 12 construction
- Filter racks
- 208/240/480 volt
- Fixed louver hood
- 12GA enclosure
- Element step control
- Can be ducted
- 24V control
- 3-year limited warranty

The CKL Series Plenum Heater

This special application unit heater is approved for use in concealed areas of buildings. It is specifically designed for highrise and office buildings, factories, auto body shops, food processing plants, plating shops and machine shops. This heater may be installed in inaccessible areas such as between a concrete ceiling and a drop tile ceiling, in an open plenum or ducted system. The heater is designed to withstand a dirty, dusty, moist or mildly corrosive environment. The heater is not intended for use where flammable vapors, gases, liquids or other combustibles are, or may be, present.

Factory Installed Options

120 Volt Control: Control components modified to accept 120V control. A circuit outboard supply is customer provided.

Element Step Control: For improved energy management additional steps can be added (refer to table).

Disconnect Switch: Available with a 3-Pole non-fused disconnect with door interlocking feature and a padlock provision.

Motor HP Upgrades: Standard models are listed with motors that will provide sufficient CFM for the kW they are designed for. Where additional CFM is required a larger motor can be provided. Up to 7.5 HP.

Remote Fuse Panel: Available when heater is mounted in an inaccessible area allowing fuses to be located in an electrical closet where they can be easily serviced.

Engineering Specifications

Contractor shall supply and install CKL Series plenum heaters manufactured by King Electrical Mfg. Company. Heaters shall be of the wattage and voltage as indicated on the plans.

Construction: The heater case is fabricated from 12 gauge high tensile electro-galvanized Steel forming a durable unibody cabinet. Heater is finished with a rust inhibiting epoxy coating.

Air Outlet Louver: Fixed louvers

Intake and Discharge Screen: Heavy gauge Steel screen protects against foreign objects entering the heater. A filter is provided to prevent dirt and dust build-up in the heater.

Air Filter: Convenient access for replacement of standard filter. Filter not included.

N.E.M.A. 12 Wiring Compartment: The wiring compartment is sealed with a 1/4" high density polyurethane gasket. This provides excellent protection against moisture, dust and dirt from invading the electrical components and wiring. All optional control accessories are N.E.M.A. 12 rated.

Spiral Fin Elements: The metal sheath element is brazed with spiral fins then molded in to a coil configuration. This combination produces the best heat transfer while eliminating the potential for hot spots by positioning the element in the maximum airflow stream.

Blower & Motor: Totally enclosed outdoor ball bearing fan motor. Permanently lubricated, class B insulation, auto-protected, permanent split capacitor and 60° C ambient. Large capacity dual inlet blower handles high static pressure and moves large air volume.

Motor leads are enclosed in a sealtight raceway to prolong equipment life and reduce maintenance.

Air Intake Temperature Control: A built-in thermostat located at the intake blower is factory set at 100°F which prevents the heater from operating when the ambient temperature exceeds this limit. This will prevent the heater from wasting energy and is an extra measure of safety.

Auto-Reset Thermal Cutout: Power is disconnected from the heater if an overheated condition occurs. The element is re-energized automatically when the normal operating temperature returns.

Internal Controls: Magnetic contactors are standard on all units. A transformer is provided for 24 Volt control. This enables the customer to use a standard low voltage thermostat. Sub circuit fusing is provided when the heater ampacity exceeds 48 Amps to comply with UL standards. A fan delay is provided standard on all models to dissipate residual heat from the heating elements.

Easy Wiring: A large wiring compartment with easy access allows for quick installation.

Mounting: The CKL heater comes with frame mounts.

Approvals: ETL Certified to comply with standard for Heating and Cooling Equipment ANSI/UL 1995 fourth edition. Meets stringent City of Chicago codes for plenum use.

Large Plenum Rated Heater CKL Series

Dimensional Data Exhaust Opening 30" x 20" Filter Size 20" x 30" x 2"

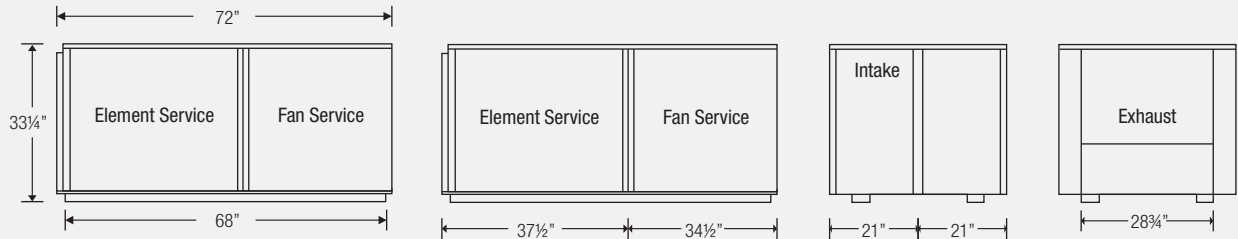

Ordering Information

MODEL	PHASE	KILO WATTS	BTUH(000)	VOLTS	AMPS	STAGES	CFM	STATIC PRESSURE	MOTOR HP	MOTOR AMPS	TEMP. RISE °F	WEIGHT lbs
CKL2030-1-3-3	1	30	102.4	208	144.2	3	3000	.25"	2	3.1	31.6°	600
CKL2430-1-3-3	1	30	102.4	240	125	3	3000	.25"	2	3.1	31.6°	600
CKL4830-1-3-3	1	30	102.4	480	62.5	2	3000	.25"	2	3.1	31.6°	600
CKL2040-1-4-3	1	40	136.5	208	192.3	4	3000	.25"	2	3.1	42.1°	650
CKL2440-1-4-3	1	40	136.5	240	166.7	4	3000	.25"	2	3.1	42.1°	650
CKL4840-1-2-3	1	40	136.5	480	83.3	2	3000	.25"	2	3.1	42.1°	650
CKL2060-1-6-3	1	60	204.8	208	288.5	6	3000	.45"	2	3.1	63.2°	650
CKL2460-1-6-3	1	60	204.8	240	250	6	3000	.45"	2	3.1	63.2°	650
CKL4860-1-3-3	1	60	204.8	480	125	3	3000	.45"	2	3.1	63.2°	650
CKL2080-1-8-3.3	1	80	273	208	384.6	8	3000	.5"	2	3.1	76.6°	700
CKL2480-1-8-3.3	1	80	273	240	333.3	8	3000	.5"	2	3.1	76.6°	700
CKL4880-1-4-3.3	1	80	273	480	166.7	4	3000	.5"	2	3.1	76.6°	700
CKL2030-3-2-3	3	30	102.4	208	83.3	2	3000	.25	2	3.1	31.6°	600
CKL2430-3-2-3	3	30	102.4	240	72.2	2	3000	.25	2	3.1	31.6°	600
CKL4830-3-1-3	3	30	102.4	480	36.1	1	3000	.25	2	3.1	31.6°	600
CKL2040-3-3-3	3	40	136.5	208	111	3	3000	.25"	2	3.1	42.1°	650
CKL2440-3-2-3	3	40	136.5	240	96.2	2	3000	.25"	2	3.1	42.1°	650
CKL4840-3-2-3	3	40	136.5	480	48.1	2	3000	.25"	2	3.1	42.1°	650
CKL2060-3-4-3	3	60	204.8	208	166.5	4	3000	.45"	2	3.1	63.2°	650
CKL2460-3-3-3	3	60	204.8	240	144.3	3	3000	.45"	2	3.1	63.2°	650
CKL4860-3-2-3	3	60	204.8	480	72.2	2	3000	.45"	2	3.1	63.2°	650
CKL2080-3-5-3.3	3	80	273	208	222.1	5	3300	.5"	2	3.1	76.6°	700
CKL2480-3-4-3.3	3	80	273	240	192.5	4	3300	.5"	2	3.1	76.6°	700
CKL4880-3-3-3.3	3	80	273	480	96.2	3	3300	.5"	2	3.1	76.6°	700
CKL20100-3-6-4.1	3	100	341.3	208	277.6	6	4100	.6"	3	4.4	77.1°	850
CKL24100-3-5-4.1	3	100	341.3	240	240.6	5	4100	.6"	3	4.4	77.1°	850
CKL48100-3-4-4.1	3	100	341.3	480	120.3	4	4100	.6"	3	4.4	77.1°	850
CKL20120-3-7-5	3	120	409.6	208	333.1	7	5000	.7"	3	4.4	75.8°	850
CKL24120-3-6-5	3	120	409.6	240	288.7	6	5000	.7"	3	4.4	75.8°	850
CKL48120-3-4-5	3	120	409.6	480	144.3	4	5000	.7"	3	4.4	75.8°	850
CKL24140-3-7-5.8	3	140	477.8	240	336.8	7	5800	.75"	3	4.4	76.3°	900
CKL48140-3-5-5.8	3	140	477.8	480	168.4	5	5800	.75"	3	4.4	76.3°	900
CKL24160-3-8-6.6	3	160	546.1	240	384.9	8	6600	.8"	3	4.4	76.6°	950
CKL48160-3-6-6.6	3	160	546.1	480	192.5	6	6600	.8"	3	4.4	76.6°	950
CKL48180-3-6-7.5	3	180	614.3	480	216.5	6	7500	.9"	5	6.9	75.8°	1000
CKL48200-3-7-8.3	3	200	682.6	480	240.6	7	8300	.95"	5	6.9	76.2°	1000
CKL48220-3-8-9.2	3	220	750.9	480	264.6	8	9200	1"	5	6.9	75.5°	1000
CKL48240-3-8-10	3	240	819.1	480	288.7	8	10000	1.2"	5	6.9	75.8°	1000

**When placing an order, make sure to add ND (No Diffuser) to the model# if connecting to ductwork. * Does not include motor load. kW rating load tolerance is plus 5% and minus 10%. Consult factory for special wattages and voltages

BLOWER SPECIFICATIONS

- 1) Quiet forward curve, double inlet, dynamically balanced wheels.
- 2) Galvanized housing and wheels for increased corrosion resistance.
- 3) Keyed wheels, keyed shaft extensions and sealed ball bearings for higher horsepower motors.
- 4) 18" wheel for a maximum of 7.5 HP motor.
- 5) Airflows up to 10,000 CFM (see performance data chart above for SP up to 3.75" WG)
- 6) Galvanized mounting supports, vibro-pads and heavy duty mounting hardware.
- 7) Belt drive allows field adjustment of blower RPM to adjust for changes in system SP.

Large Plenum Rated Heater CKL Series

Internal View

Front View

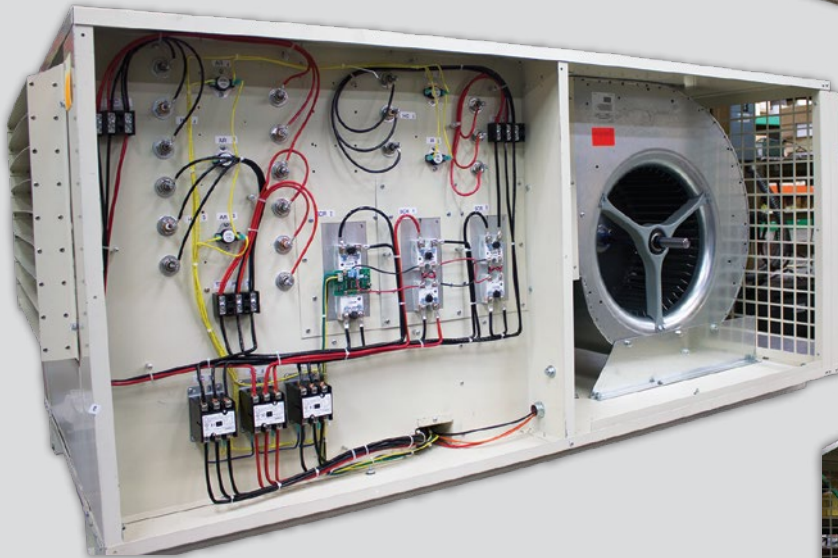
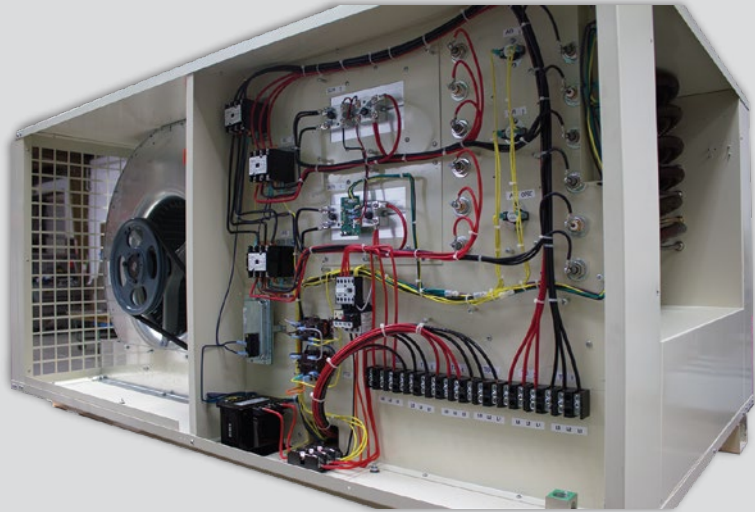

Motor & Blower



OPTIONS

STAGES Increase # of Stages on Model Number

CFM Increase CFM on Model Number

ADD SUFFIX: DESCRIPTION

STEP CONTROL 8 Stage Step Controller

SOLID STATE RELAY STEP CONTROL 8 Stage Step Controller w/ Vernier Control

CKL-RFP100 100 Amp Remote Fuse Panel

CKL-RFP200 200 Amp Remote Fuse Panel

CKL-RFP400 400 Amp Remote Fuse Panel

Explosion-Proof Heater Model FX5



Model Code:

FX5	480	3	60	300	W
A	B	C	D	E	F
A: Model Series, 5th Generation					
B: 208V, 240V, 480V, 600V					
C: 1-Phase, 3-Phase					
D: 50 Hertz, 60 Hertz					
E: Heater Kilowatts					
F: Welded Core					



- Rated for Class 1, Div. 1 & 2 applications
- Explosion proof motor
- Aluminum fan
- High temperature limit
- Multiple wattages available
- Wall or ceiling mount
- 14 gauge powder coated steel
- 3-year limited warranty

Explosion-Proof Heater

FX5 heaters are cULus certified for use in hazardous locations. They are designed for the harshest environments such as: dry indoor industrial applications, oil refineries, petrochemical plants, pulp and paper mills, grain elevators, hazardous waste storage facilities, wastewater treatment plants, etc., where specific explosive gases or dusts may be present. The FX5 offers a larger junction box for easier installation, additional limit controls and a heavy duty core. The heater core assembly is contained in a sturdy, epoxy-coated 14-gauge steel cabinet, which also carries the motor and fan assembly. Adjustable louvres allow directional control of the airflow. A narrow gap, two-piece fan guard is provided to shield all moving parts. All fasteners are zinc plated for corrosion protection. FX heaters are built to last. All FX products are subjected to exhaustive technical analysis and testing during design and development, and are manufactured under a registered quality assurance program. As a result, they have consistently proven their safety and reliability. For hazardous location heating, rely on the King FX5 heater for the most dependable, trouble-free service available. Suitable for the following hazardous location classifications: •Class I, Divisions 1 & 2, Groups C & D, •Class II, Divisions 1 & 2, Groups E, F & G, •Class I, Zones 1 & 2, Groups IIA & IIB, •Temperature Code T3B 165°C (329°F)

Engineering Specifications

Contractor shall supply and install FX5 Series unit heaters manufactured by King Electrical Mfg. Company. Heaters shall be of the wattage and voltage as indicated on the plans.

Hazardous Locations Classifications: Class I, Divisions 1 & 2, Group C & D
 • Class II, Divisions 1 & 2, Group E, F & G • Class I, Zones 1 & 2, Group IIA & IIB
 • Temperature Code T3B 165°C (329°F)

Motor Type: Explosion-proof. Thermally protected. Permanently lubricated ball bearings.

Fan: Aluminum blade. Steel spider and hub with 5/8" (15 mm) bore.

Fan Guard: Split design with close wire spacing. 1/4" (6.3 mm) diameter probe will not enter.

Mounting Holes: Four 9/16" (14 mm) diameter holes at the top of heater.

Heating Elements: Long-life metal-sheathed elements (Propylene Glycol).

Temperature High-Limit: Automatic reset type, snap-action bimetal, open on temperature rise. Rated 100,000 cycles at 10 amp, handles 0.128 amps, plus an additional ambient high limit.

Control Circuit: 120V, 0.128 amps, 15VA. (Grounded).

Optional Built-In Thermostat: Explosion-proof 2°C to 28°C (36°F to 82°F).

Control Transformer: Multiple voltage primary, 120V secondary, 25VA.

Contactors: 40 or 75 amp. Rated for 500,000 mechanical operations. 120V, 15VA coil (separately fuse-protected).

Cabinet Material: 14-gauge (0.075" / 1 mm) epoxy powder coated steel.

Optional Heresite® coating available for corrosive atmospheres with an optional stainless-steel casing.

Core: HD Core

Conduit Material: Heavy wall, 0.122" (3 mm), steel

Overpressure Protection: Preset 100psi (690kPa) pressure relief valve, aluminum body, no serviceable parts.

Operational Temperature Range: -20°C to 40°C (-4°F to 104°F)

Junction Box (HxWxD): 10.25" (230 mm) x 8.00" (180 mm) x 9.12" (205 mm).

Field Connection: Two 1" NPT

Weight (for 15kW unit): 168 lbs (76.36 kgs)

Weight With Disconnect (for 15kW unit): 180 lbs (81.82 kgs)

Optional Built-In Disconnect Switch: DS5 uses x-Max® construction

Optional Pilot Light: Explosion-proof light fixture with replaceable bulb

Optional 3-Way Switch: Explosion-proof 3 position fan switch (on, off, fan only)

WARRANTY: Under normal use the Company warrants to the purchaser that defects in material or workmanship will be repaired or replaced without charge for a period of 36 months from date of shipment. Any claim for warranty must be reported to the sales office where the product was purchased for authorized repair or replacement within the terms of this warranty.

Note:(*) Exceeds the 48 amp. circuit limit of NEC 424-22 (*) 480 1 Phase units are certified Class I, Div. 1, Group D and Class II, Div.1, Groups F and G.

Minimum conductor size for 30°C (86°F) ambient. Derate conductor for ambient temperature. Use minimum 90°C (194°F) insulation.

Heater is functioning normally if at rated voltage the amp draw is within 10% of the value in this table.

Operation at lower voltage will result in reduced heat output and amp draw.

Explosion-Proof Heater Model FX5

Ordering Information - Performance Data for 60 Hertz FX5, Temperature Code T3B 165°C (329°F)

MODEL	VOLTS	PHASE	NOMINAL WATTAGE (kW)	AMPS	OPTIONAL BUILT-IN DISCONNECT SWITCH	AIR TEMP. RISE	BTU/HR
FX5-208160-030	208	1	3	14.4	DS5	11.2°F (6.2°C)	10,236
FX5-208360-030	208	3	3	8.3	DS5	11.2°F (6.2°C)	10,236
FX5-240160-030	240	1	3	12.5	DS5	11.2°F (6.2°C)	10,236
FX5-240360-030	240	3	3	7.2	DS5	11.2°F (6.2°C)	10,236
FX5-480160-030 ¹	480	1	3	6.3	DS5	11.2°F (6.2°C)	10,236
FX5-480360-030	480	3	3	3.6	DS5	11.2°F (6.2°C)	10,236
FX5-600360-030	600	3	3	2.9	DS5	11.2°F (6.2°C)	10,236
FX5-208160-050	208	1	5	24.0	DS5	18.6°F (10.3°C)	17,060
FX5-208360-050	208	3	5	13.9	DS5	18.6°F (10.3°C)	17,060
FX5-240160-050	240	1	5	20.8	DS5	18.6°F (10.3°C)	17,060
FX5-240360-050	240	3	5	12.0	DS5	18.6°F (10.3°C)	17,060
FX5-480160-050 ¹	480	1	5	10.4	DS5	18.6°F (10.3°C)	17,060
FX5-480360-050	480	3	5	6.0	DS5	18.6°F (10.3°C)	17,060
FX5-600360-050	600	3	5	4.8	DS5	18.6°F (10.3°C)	17,060
FX5-208160-075	208	1	7.5	36.1	DS5	27.9°F (15.5°C)	25,590
FX5-208360-075	208	3	7.5	20.8	DS5	27.9°F (15.5°C)	25,590
FX5-240160-075	240	1	7.5	31.3	DS5	27.9°F (15.5°C)	25,590
FX5-240360-075	240	3	7.5	18.0	DS5	27.9°F (15.5°C)	25,590
FX5-480160-075 ¹	480	1	7.5	15.6	DS5	27.9°F (15.5°C)	25,590
FX5-480360-075	480	3	7.5	9.0	DS5	27.9°F (15.5°C)	25,590
FX5-600360-075	600	3	7.5	7.2	DS5	27.9°F (15.5°C)	25,590
FX5-208160-100*	208	1	10	48.1	NOT AVAILABLE	37.2°F (20.6°C)	34,120
FX5-208360-100	208	3	10	27.8	DS5	37.2°F (20.6°C)	34,120
FX5-240160-100	240	1	10	41.7	DS5	37.2°F (20.6°C)	34,120
FX5-240360-100	240	3	10	24.1	DS5	37.2°F (20.6°C)	34,120
FX5-480160-100 ¹	480	1	10	20.8	DS5	37.2°F (20.6°C)	34,120
FX5-480360-100	480	3	10	12.0	DS5	37.2°F (20.6°C)	34,120
FX5-600360-100	600	3	10	9.6	DS5	37.2°F (20.6°C)	34,120
FX5-240160-150*	240	1	15	62.5	NOT AVAILABLE	27.1°F (15.1°C)	51,180
FX5-240360-150	240	3	15	36.1	DS5	27.1°F (15.1°C)	51,180
FX5-480160-150 ¹	480	1	15	31.3	DS5	27.1°F (15.1°C)	51,180
FX5-480360-150	480	3	15	18.0	DS5	27.1°F (15.1°C)	51,180
FX5-600360-150	600	3	15	14.4	DS5	27.1°F (15.1°C)	51,180
FX5-480160-200 ¹	480	1	20	41.7	DS5	36.1°F (20.1°C)	68,240
FX5-480360-200	480	3	20	24.1	DS5	36.1°F (20.1°C)	68,240
FX5-600360-200	600	3	20	19.2	DS5	36.1°F (20.1°C)	68,240
FX5-480360-250	480	3	25	30.1	DS5	22.0°F (12.2°C)	85,300
FX5-600360-250	600	3	25	24.1	DS5	36.1°F (20.1°C)	85,300
FX5-480360-300	480	3	30	36.1	DS5	26.4°F (14.6°C)	102,360
FX5-600360-300	600	3	30	28.9	DS5	26.4°F (14.6°C)	102,360
FX5-480360-350	480	3	35	42.1	DS5	30.7°F (17.1°C)	119,420
FX5-600360-350	600	3	35	33.7	DS5	30.7°F (17.1°C)	119,420

Options

ADD SUFFIX	DESCRIPTION
-T	Built-in thermostat.
-D	Built-in disconnect switch.
-P	Built-in pilot light.
-S	3-way switch.
-H	High "off" (deenergized) ambient temperatures.
-C	Heresite
-A	Stainless-steel cabinet.

Explosion-Proof Heater Model FX5

Ordering Information - Performance Data for 50 Hertz FX5, Temperature Code T3B 165°C (329°F)

MODEL	VOLTS	PHASE	NOMINAL WATTAGE (kW)	AMPS	OPTIONAL BUILT-IN DISCONNECT SWITCH	AIR TEMP. RISE	BTU/HR
FX5-220150-025	220	1	2.5	11.4	DS5	11.2°F (6.3°C)	8,530
FX5-220150-042	220	1	4.2	19.1	DS5	19.0°F (10.5°C)	14,330
FX5-220150-063	220	1	6.3	28.6	DS5	28.5°F (15.7°C)	21,495
FX5-220150-084	220	1	8.4	38.2	DS5	37.8°F (21.1°C)	28,660
FX5-220150-126*	220	1	12.6	57.3	NOT AVAILABLE	27.5°F (15.2°C)	42,991
FX5-230150-028	230	1	2.8	12.2	DS5	12.5°F (7.0°C)	9,553
FX5-230150-046	230	1	4.6	20.0	DS5	20.7°F (11.5°C)	15,695
FX5-230150-069	230	1	6.9	30.0	DS5	31.1°F (17.2°C)	23,542
FX5-230150-138*	230	1	13.8	59.9	NOT AVAILABLE	30.1°F (16.6°C)	47,086
FX5-380350-025	380	3	2.5	3.8	DS5	11.2°F (6.3°C)	8,530
FX5-380350-042	380	3	4.6	6.4	DS5	19.0°F (10.5°C)	15,695
FX5-380350-063	380	3	8.4	9.6	DS5	28.5°F (15.7°C)	28,661
FX5-380350-084	380	3	6.3	12.8	DS5	37.8°F (21.1°C)	21,496
FX5-380350-125	380	3	12.5	19.0	DS5	27.5°F (15.2°C)	42,650
FX5-380350-209	380	3	20.9	31.8	DS5	22.0°F (12.1°C)	71,311
FX5-400350-028	400	3	2.8	4.0	DS5	12.5°F (7.0°C)	9,554
FX5-400350-046	400	3	4.6	6.6	DS5	20.7°F (11.5°C)	15,695
FX5-400350-069	400	3	6.9	10.0	DS5	31.1°F (17.2°C)	23,543
FX5-400350-093	400	3	9.3	13.4	DS5	42.0°F (23.2°C)	31,732
FX5-400350-139	400	3	13.9	20.1	DS5	30.2°F (16.7°C)	47,427
FX5-400350-185	400	3	18.5	26.7	DS5	40.2°F (22.3°C)	63,122
FX5-400350-231	400	3	23.1	33.3	DS5	24.2°F (13.5°C)	78,817
FX5-415350-037	415	3	3.7	5.1	DS5	16.6°F (9.2°C)	12,624
FX5-415350-075	415	3	7.5	10.4	DS5	33.8°F (18.7°C)	25,590
FX5-415350-149	415	3	14.9	20.7	DS5	32.5°F (18.1°C)	50,839
FX5-415350-224	415	3	22.4	31.2	DS5	23.5°F (13.1°C)	76,429
FX5-440350-042	440	3	4.2	5.5	DS5	19.0°F (10.5°C)	14,330
FX5-440350-084	440	3	8.4	11.0	DS5	37.8°F (21.1°C)	28,661
FX5-440350-168	440	3	16.8	27.5	DS5	36.5°F (20.3°C)	57,322
FX5-440350-209	440	3	20.9	27.5	DS5	22.1°F (12.2°C)	71,311

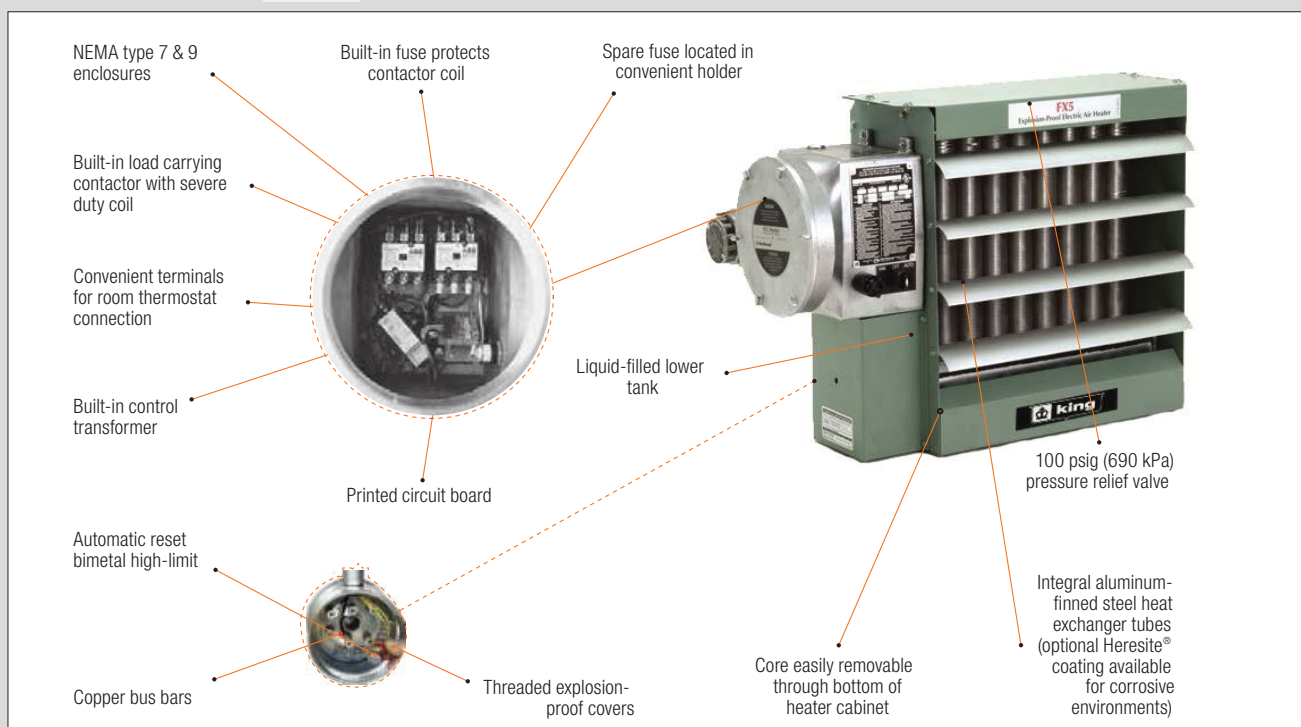

Explosion-Proof Heater Model FX5

Specifications - 60 Hertz FX5

NOMINAL WATTAGE (kW)	MAX. ALTITUDE (FT)	AIR DELIVERY @70°F (CFM)	HORIZONTAL THROW (FT)	MAX. MOUNTING HEIGHT (FT)	MOTOR POWER (W)	MOTOR SPEED (RPM)	FAN DIAMETER (in)	NET WEIGHT (lbs)		SHIPPING WEIGHT (lbs)	
								WITH DS5	WITHOUT DS5	WITH DS5	WITHOUT DS5
3	12,000	850	30	10	373	1,725	12	152	140	206	194
5	8,000	850	30	10	373	1,725	12	152	140	206	194
7.5	10,000	850	30	10	373	1,725	12	152	140	206	194
10	7,000	850	30	10	373	1,725	12	152	140	206	194
15	10,000	1,750	40	10	373	1,725	16	180	168	230	218
20	7,000	1,750	40	10	373	1,725	16	180	168	230	218
25	10,000	3,600	70	20	373	1,725	20	213	201	264	252
30	7,000	3,600	70	20	373	1,725	20	213	201	264	252
35	6,000	3,600	70	20	373	1,725	20	213	201	264	252

Manufacturer reserves the right to replace motors with suitable alternate. Weights are an approximate maximum

Specifications - 50 Hertz FX5

NOMINAL WATTAGE (kW)	MAX. ALTITUDE (FT)	AIR DELIVERY @70°F (CFM)	HORIZONTAL THROW (FT)	MAX. MOUNTING HEIGHT (FT)	MOTOR POWER (W)	MOTOR SPEED (RPM)	FAN DIAMETER (in)	NET WEIGHT (lbs)		SHIPPING WEIGHT (lbs)	
								WITH DS5	WITHOUT DS5	WITH DS5	WITHOUT DS5
2.5	12,000	700	25	10	187	1,437	12	152	140	206	194
3.7 & 4.2	8,000	700	25	10	187	1,437	12	152	140	206	194
6.3 & 7.5	10,000	700	25	10	187	1,437	12	152	140	206	194
8.4	7,000	700	25	10	187	1,437	12	152	140	206	194
12.5 & 12.6	10,000	1,450	35	10	187	1,437	16	180	168	230	218
14.9 & 16.7	7,000	1,450	35	10	187	1,437	16	180	168	230	218
20.9	10,000	3,000	60	20	187	1,437	16	213	201	264	252
22.4	7,000	3,000	60	20	187	1,437	16	213	201	264	252

Manufacturer reserves the right to replace motors with suitable alternate. Weights are an approximate maximum

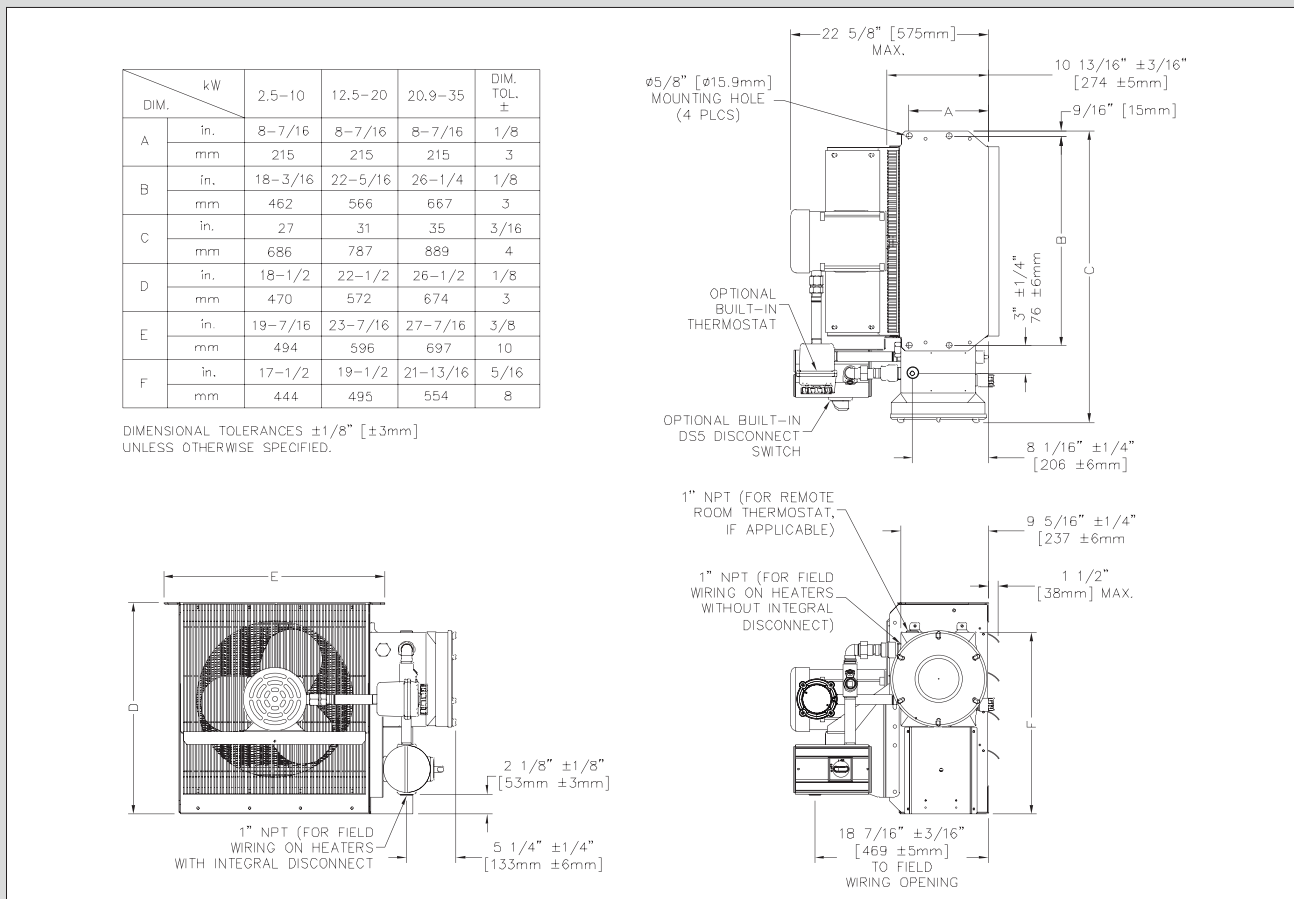

Explosion-Proof Heater Model CX1



Model Code:

CX1	220	1	60	012	T2A	IIB	T
A	B	C	D	E	F	G	H

- A: Model Series
- B: 120, 208, 240, 277, 380, 400, 415
480, 600 volt options
- C: 1-Phase
- D: 50 Hertz, 60 Hertz
- E: Heater Kilowatts
- F: Rated Area (Temperature)
T2a=536°F, T3=392°F
- G: T-Code (Grouping) IIB=Group C & D
IIC=Group A, B, C & D
- H: T=Built-In Thermostat



- Sloped-top cabinet
- No exposed copper or brass
- High-velocity airflow
- 14GA steel cabinet
- Available with stainless-steel construction
- One of the shortest cabinet lengths available
- Optional built-in thermostat
- Incoloy® 840 heating elements
- Radial-embossed aluminum plate fins
- Galvanized steel mounting brackets
- IP55 moisture ingress protection
- Approvals - Groups A, B, C, D; IIA, IIB & IIC; available

CX1 Explosion-Proof Heater

For hazardous locations heating, rely on the Ruffneck™ CX1 ProVector® for the most dependable, trouble-free service available. Explosion-proof air heaters were designed to satisfy the demanding requirements of the oil and gas well drilling industry. The harsh operating conditions of this application require the utmost in heater reliability.

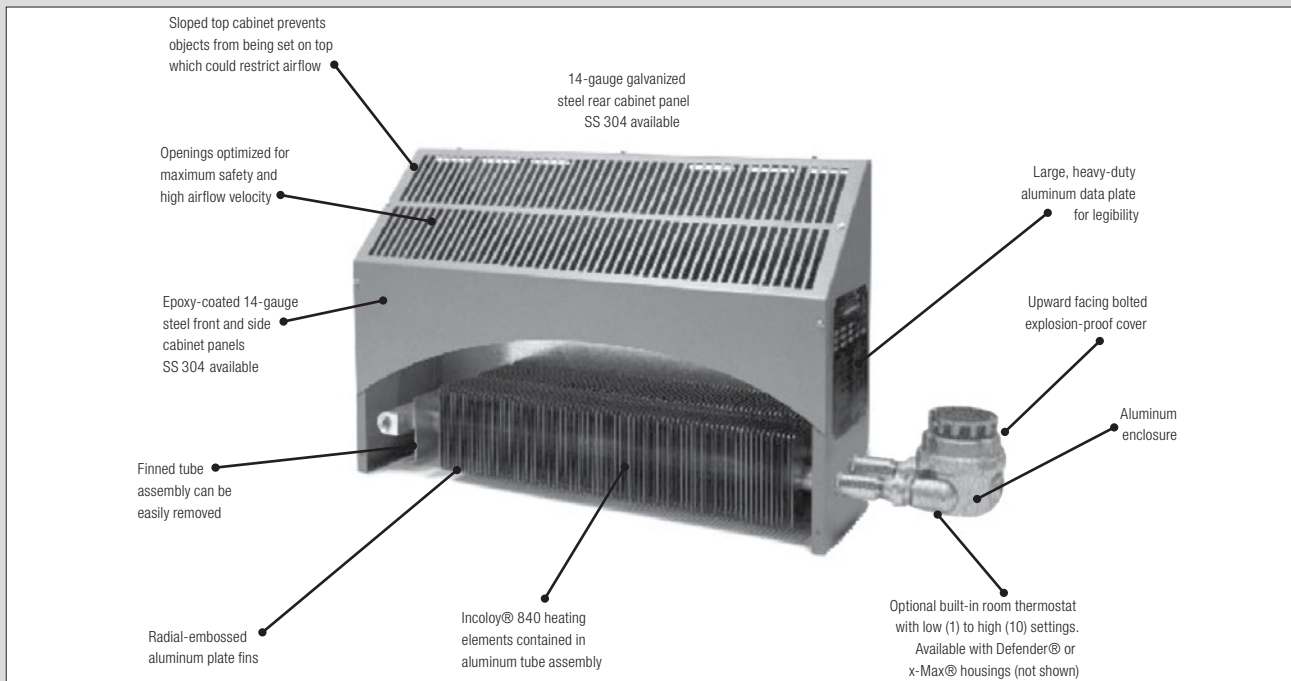

Engineering Specifications

Contractor shall supply and install CX1 Series explosion-proof heaters by King Electrical Mfg. Company. Heaters shall be of the wattage and voltage as indicated on the plans.

Hazardous Location Classifications

Without Built-in Thermostat: Defender® housing Class I, Div. 1 & 2, Groups B, C, & D; Zones 1 & 2, Groups IIA, IIB + H,x-Max® housing Class I, Div. 1 & 2, Groups A, B, C, & D; Zones 1 & 2, Groups IIA, IIB, & IIC.

With Built-in Thermostat: XCT Defender® thermostat: Class I, Div. 1 & 2, Groups C & D; Zones 1 & 2, Groups IIA & IIB XT thermostat: Class I, Div. 1 & 2, Groups A, B, C, & D; Zones 1 & 2, Groups IIA, IIB, & IIC.

Enclosure: Defender® housing is cast aluminum with bolt on cover. Groups IIB, x-Max® housing is extruded aluminum with two screwed on covers. The x-Max® housing offers IP55 moisture ingress protection. Groups IIC.

Mounting Brackets: Two 14-gauge (0.075" / 12 mm) galvanized steel brackets for standard cabinet. Stainless-steel brackets provided with optional stainless-steel cabinet.

Heating Elements: Two Incoloy® 840 sheathed elements

Temperature Code Rating: Temperature Code T2A - 536°F (280°C) or T3 - 392°F (200°C).

Temperature Limitations: Operational: -49°F to 104°F (-45°C to 40°C) Storage: -49°F to 176°F (-45°C to 80°C). Optional up to 300°F (149°C) available.

Cabinet Material: 14-gauge (0.075" / 1.90mm) epoxy coated steel with galvanized rear panel. Optional - 14-gauge 304 stainless-steel cabinet and mounting hardware available

Explosion-Proof Heater Model CX1

Ordering Information - Performance Data for CX1 ProVector®

MODEL	kW (BTU/hr)	UNIT VOLTAGE (VOLTS)	BASIC UNIT	GAS GROUP				SUPPLY WIRE SIZE (AWG)***	UNIT CURRENT (AMPS)	MAX. CIRCUIT FUSE (AMPS)*	CABINET LENGTH in(mm)	TEMP. CODE
				IIB+H2 W/O T'STAT	IIB W/ T'STAT	IIC W/O T'STAT	IIC W/ T'STAT					
CX1-120160-012-T3	1.2	120	•	•	•	•	•	12	10.0	15	31.3 (796)	T3
CX1-120160-018-T3	1.8	120	•	•	•	•	•	12	15.0	20	31.3 (796)	T3
CX1-208160-012-T3	1.2	208	•	•	•	•	•	12	5.8	15	31.3 (796)	T3
CX1-208160-018-T3	1.8	208	•	•	•	•	•	12	8.7	15	31.3 (796)	T3
CX1-208160-036-T3**	3.6	208	•	•	•	•	•	12	17.3	20	49.5 (1256)	T3
CX1-208160-048-T2A	4.8	208	•	•	•	•	•	8	23.1	25	49.5 (1256)	T2A
CX1-208160-076-T2A	7.6	208	•	•	•	•	•	8	36.5	40	59.5 (1511)	T2A
CX1-240160-012-T3	1.2	240	•	•	•	•	•	12	5.0	15	31.3 (796)	T3
CX1-240160-018-T3	1.8	240	•	•	•	•	•	12	7.5	15	31.3 (796)	T3
CX1-240160-036-T3**	3.6	240	•	•	•	•	•	12	15.0	20	49.5 (1256)	T3
CX1-240160-048-T2A	4.8	240	•	•	•	•	•	10	20.0	25	49.5 (1256)	T2A
CX1-240160-076-T2A	7.6	240	•	•	•	•	•	8	31.7	35	59.5 (1511)	T2A
CX1-277160-012-T3	1.2	277	•	•	•	•	•	12	4.3	15	31.3 (796)	T3
CX1-277160-018-T3	1.8	277	•	•	•	•	•	12	6.5	15	31.3 (796)	T3
CX1-277160-036-T3**	3.6	277	•	•	•	•	•	12	13.0	15	49.5 (1256)	T3
CX1-277160-048-T2A	4.8	277	•	•	•	•	•	12	17.3	20	49.5 (1256)	T2A
CX1-277160-076-T2A	7.6	277	•	•	•	•	•	8	27.4	30	59.5 (1511)	T2A
CX1-380160-0075-T3	0.75	380	•	•	•	•	•	12	2.0	15	31.3 (796)	T3
CX1-380160-0113-T3	1.13	380	•	•	•	•	•	12	3.0	15	31.3 (796)	T3
CX1-380160-012-T3	1.2	380	•	•	•	•	•	12	3.2	15	31.3 (796)	T3
CX1-380160-018-T3	1.8	380	•	•	•	•	•	12	4.7	15	31.3 (796)	T3
CX1-380160-0226-T2A	2.26	380	•	•	•	•	•	12	5.9	15	31.3 (796)	T2A
CX1-380160-0301-T3	3.01	380	•	•	•	•	•	12	7.9	15	49.5 (1256)	T3
CX1-380160-036-T3**	3.6	380	•	•	•	•	•	12	9.5	15	49.5 (1256)	T3
CX1-380160-0476-T2A	4.76	380	•	•	•	•	•	10	12.5	15	59.5 (1511)	T2A
CX1-380160-048-T2A	4.8	380	•	•	•	•	•	12	12.6	15	49.5 (1256)	T2A
CX1-380160-076-T2A	7.6	380	•	•	•	•	•	10	20.0	25	59.5 (1511)	T2A
CX1-400160-0083-T3	0.83	400	•	•	•	•	•	12	2.1	15	31.3 (796)	T3
CX1-400160-012-T3	1.2	400	•	•	•	•	•	12	3.0	15	31.3 (796)	T3
CX1-400160-0125-T3	1.25	400	•	•	•	•	•	12	3.1	15	31.3 (796)	T3
CX1-400160-018-T3	1.8	400	•	•	•	•	•	12	4.5	15	31.3 (796)	T3
CX1-400160-025-T2A	2.5	400	•	•	•	•	•	12	6.3	15	31.3 (796)	T2A
CX1-400160-0333-T3	3.33	400	•	•	•	•	•	12	8.3	15	49.5 (1256)	T3
CX1-400160-036-T3**	3.6	400	•	•	•	•	•	12	9.0	15	49.5 (1256)	T3
CX1-400160-048-T2A	4.8	400	•	•	•	•	•	12	12.0	15	49.5 (1256)	T2A
CX1-400160-0528-T2A	5.28	400	•	•	•	•	•	10	13.2	15	59.5 (1511)	T2A
CX1-400160-076-T2A	7.6	400	•	•	•	•	•	10	19.0	20	59.5 (1511)	T2A
CX1-415160-009-T3	0.9	415	•	•	•	•	•	12	2.2	15	31.3 (796)	T3
CX1-415160-012-T3	1.2	415	•	•	•	•	•	12	2.9	15	31.3 (796)	T3
CX1-415160-0135-T3	1.35	415	•	•	•	•	•	12	3.3	15	31.3 (796)	T3
CX1-415160-018-T3	1.8	415	•	•	•	•	•	12	4.3	15	31.3 (796)	T3
CX1-415160-0269-T2A	2.69	415	•	•	•	•	•	12	6.5	15	31.3 (796)	T2A
CX1-415160-0359-T3	3.59	415	•	•	•	•	•	12	8.7	15	49.5 (1256)	T3
CX1-415160-036-T3**	3.6	415	•	•	•	•	•	12	8.7	15	49.5 (1256)	T3
CX1-415160-048-T2A	4.8	415	•	•	•	•	•	12	11.6	15	49.5 (1256)	T2A
CX1-415160-0568-T2A	5.68	415	•	•	•	•	•	10	13.7	15	59.5 (1511)	T2A
CX1-415160-076-T2A	7.6	415	•	•	•	•	•	10	18.3	20	59.5 (1511)	T2A
CX1-480160-012-T3	1.2	480	•	•	•	•	•	12	2.5	15	31.3 (796)	T3
CX1-480160-018-T3	1.8	480	•	•	•	•	•	12	3.8	15	31.3 (796)	T3
CX1-480160-036-T3**	3.6	480	•	•	•	•	•	12	7.5	15	49.5 (1256)	T3
CX1-480160-048-T2A	4.8	480	•	•	•	•	•	12	10.0	15	49.5 (1256)	T2A
CX1-480160-076-T2A	7.6	480	•	•	•	•	•	10	15.8	20	59.5 (1511)	T2A
CX1-600160-012-T3	1.2	600	•	•	•	•	•	12	2.0	15	31.3 (796)	T3
CX1-600160-018-T3	1.8	600	•	•	•	•	•	12	3.0	15	31.3 (796)	T3
CX1-600160-036-T3**	3.6	600	•	•	•	•	•	12	6.0	15	49.5 (1256)	T3
CX1-600160-048-T2A	4.8	600	•	•	•	•	•	12	8.0	15	49.5 (1256)	T2A
CX1-600160-076-T2A	7.6	600	•	•	•	•	•	12	12.7	15	59.5 (1511)	T2A

Explosion-Proof Heater Model CX1

All units are single phase

*Or equivalent breaker as per local electrical inspection authority requirements.

** For 3.6 kW heaters rated T3 cabinet length is 49.5" (1256mm). 3.6 kW heaters rated T2A cabinet length is 31.3" (796mm)

*** Ensure supply wire size adheres to applicable local and national electrical codes

Notes

1. Heater is functioning normally if, at rated voltage, the current draw is within 10% of the value in this table.
2. Operation at lower voltages that rated will result in reduced output and current draw.
Actual Output (kW) = [(Supply Voltage) ÷ (Rated Voltage)]² × Rated Unit Wattage (kW)
3. Add suffix "T" for optional built-in thermostat. Thermostat not available on IIB + H models.

4. Add suffix "H" for high-temperature ambient storage option. High temperature storage option is not available with thermostat option. Not available on IIB models.

5. For IIB model with XCT built-in thermostat - Class I, Div. 1 & 2, Groups C & D; Zones 1 & 2, Groups IIA and IIB

6. For IIC model with XT built-in thermostat - Class I, Div. 1 & 2, Groups A,B,C & D; Zones 1 & 2, Groups IIA, IIB, IIC

7. IIC Grouping units come with x-Max® housing

8. Remote mounted, Defender, explosion-proof room thermostats are not suitable for Group B & IIC applications

9. Remote contactors are required on all 600V heaters, and heaters with a current draw greater than 22 amps

(supplied & installed by others), when utilizing XT-311 remote thermostat.

10. Temperature code ratings: T2A - 536°F (280°C), T3 - 392°F (200°C)

Specifications

NOMINAL WATTAGE (kW)	CABINET LENGTH "B"	NET WEIGHT (lbs)	SHIPPING WEIGHT (lbs)
0.75 - 2.69 & 3.6 (T2A)	31.3	55.3	65
3.01 - 3.59 & 3.6 (T3) & 4.8	49.4	80.7	92.8
4.76, 5.28 - 7.6	59.5	95	105

CX1 ProVector® Physical Dimensions with x-Max® housing

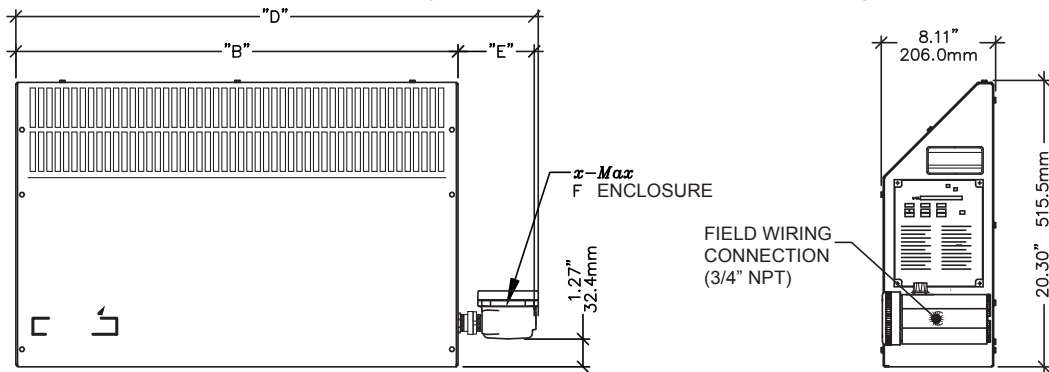

HEATER KW RATING	"D" DIMENSION		"B" DIMENSION	"E" DIMENSION	
	W/ EXTENSION	WITH EXTENSION		W/ EXTENSION	WITH EXTENSION
0.75 - 2.69, 3.6 (T2A)	37.6" 954mm	39.6" 1007mm	31.34" 796.0mm	6.2" 158mm	8.3" 211mm
3.01 - 3.59, 3.6 (T3), 4.8	55.7" 1414mm	57.8" 1467mm	49.45" 1256.0mm	6.2" 158mm	8.3" 211mm
4.76, 5.28 - 7.6	65.7" 1669mm	67.8" 1722mm	59.49" 1511.0mm	6.2" 158mm	8.3" 211mm

CX1 ProVector® Physical Dimensions with Defender® housing

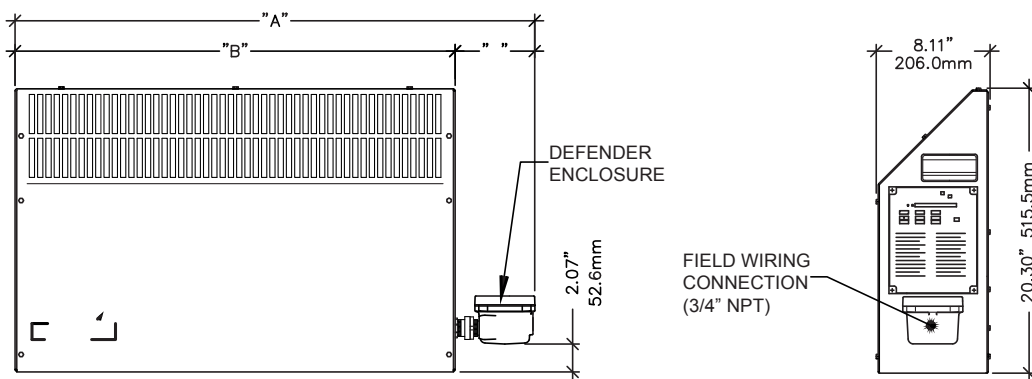

HEATER KW RATING	"A" DIMENSION		"B" DIMENSION	"C" DIMENSION	
	W/ EXTENSION	WITH EXTENSION		W/ EXTENSION	WITH EXTENSION
0.75 - 2.69, 3.6 (T2A)	36.9" 938mm	39.0" 991mm	31.34" 796.0mm	.6" 142mm	7.7" 195mm
3.01 - 3.59, 3.6 (T3), 4.8	55.0" 1398mm	57.1" 1441mm	49.4" 1256.0mm	5.6" 142mm	7.7" 195mm
4.76, 5.28 - 7.6	65.1" 1653mm	67.2" 1706mm	59.49" 1511.0mm	.6" 142mm	7.7" 195mm

Notes: Heaters with built-in thermostat come with tube extensions.

Electronic Portable Unit Heater PKB Series



PLATINUM

Model Code:

PKB	20	10	-1
A	B	C	D
A: Series			
B: 20 - 208V, 24 - 240V 48 - 480V			
C: KW (10)			
D: 1-Phase, 3-Phase			

- Platinum electronic temperature controller
- Large LED display
- Remote control included
- Fan Only & timer modes
- Patented Smart Limit Protection®
- Adjustable louvers
- Unit bearing motor
- Spiral finned heat elements
- Standard color: Textured gray
- 6ft. SO cord (no plug)
- Heavy duty 16 gauge wheel base
- 2-year limited warranty



The PKB Platinum Electronic Portable Utility Heater

King's PKB Electronic Portable Utility Heaters are the most full-featured utility heaters on the market, with in-built Platinum electronic thermostat for accuracy and remote control for simple operation. With integrated summer fan only and thermostat timer mode, the PKB Platinum has you covered. Constructed to hold up to the rigorous demands of a jobsite or industrial facility. It is the best heat source to assist in dry-out applications where dry electric heat is preferred to propane or kerosene space heaters. In addition, electric heat has no odor, flame or carbon monoxide. The high CFM and low temperature rise are also key features to make the PKB Platinum the best solution for temporary large capacity heating applications. Spiral finned steel elements and high CFM ensure even air distribution producing cooler element operation, prolonging heater life.

Ordering Information

	MODEL	KW	BTUH	PHASE	VOLTS	AMPS	CFM	SIZE	SO CORD SIZE	
208V	PKB2007-1-P	7.5	25.6	1	208	36.1	600	A	8/3	
	PKB2007-3-P	7.5	25.6	3	208	20.8	600	B	10/4	
	PKB2010-1-P	10	34.1	1	208	48	725	A	6/3	
	PKB2010-3-P	10	34.1	3	208	27.7	725	B	8/4	
	PKB2015-1-P-FB	15	51.2	1	208	72.1	925	B	2/3	
	PKB2015-3-P	15	51.2	3	208	36.1	925	B	6/4	
240/ 208V	PKB2020-3-P-FB	20	68.2	3	208	55.5	1100	C	4/3	
	PKB2407-1-P	7.5/5.6	25.6/19.2	1	240/208*	31.3/26.9	600	A	8/3	
	PKB2407-3-P	7.5/5.6	25.6/19.2	3	240/208*	18.0/15.6	600	B	12/4	
	PKB2410-1-P	10/7.5	34.1/25.6	1	240/208*	41.7/36.1	725	A	6/3	
	PKB2410-3-P	10/7.5	34.1/25.6	3	240/208*	24.1/20.8	725	B	10/4	
	PKB2412-1-P-FB	12.5/9.4	42.7/32.0	1	240/208*	52.1/45.1	825	B	6/3	
	PKB2412-3-P	12.5/9.4	42.7/32.0	3	240/208*	30.1/26.1	825	B	8/4	
	PKB2415-1-P-FB	15/11.25	51.2/38.4	1	240/208*	62.5/54.1	925	B	4/3	
	PKB2415-3-P	15/11.25	51.2/38.4	3	240/208*	36.1/54.1	925	B	6/4	
	PKB2420-3-P-FB	20/15	68.2/51.20	3	240/208*	48.1/41.6	1100	C	4/4	
	480V	PKB4807-1-P	7.5	25.6	1	480	15.6	600	B	14/3
		PKB4807-3-P	7.5	25.6	3	480	9	600	B	16/4
PKB4810-1-P		10	34.1	1	480	20.8	725	B	12/3	
PKB4810-3-P		10	34.1	3	480	12	725	B	14/4	
PKB4812-1-P		12.5	42.7	1	480	26	825	B	10/3	
PKB4812-3-P		12.5	42.7	3	480	15.1	825	B	12/4	
PKB4815-1-P		15	51.2	1	480	31.3	925	B	8/3	
PKB4815-3-P		15	51.2	3	480	18.1	925	B	12/4	
PKB4820-3-P	20	68.2	3	480	24.1	1100	C	10/4		

*Dual rated heaters will draw 13% less amps and 25% less wattage when operated at 208V.

Electronic Portable Unit Heater PKB Series

Platinum Electronic Controller Features

- Electronic control for accuracy
- Thermostat timer mode (1-9 Hours)
- Summer Fan only mode
- Large LED display
- Built-In fan delay
- Remote control included



Engineering Specifications

Contractor shall supply and install PKB Series electronic utility heaters manufactured by King Electrical Mfg. Company. Heaters shall be of the wattage and voltage as indicated on the plans.

Construction: All exterior and interior metal enclosure parts are made from 20 gauge electrogalvanized Steel with a rust inhibiting baked enamel finish. Smooth rounded corners and protective edge trim give an attractive modern appearance.

Electronic Control: Up, down temperature mode. Start/Stop. Standard on all heaters. The control voltage is equal to the line voltage (208, 240) for 5kW the line voltage control is operating the contactors.

Adjustable Outlet Louver: Louvers direct air up or down as needed for the heating application.

Rear Intake Screen: Heavy gauge steel screen protects against foreign objects making accidental contact with the rotating fan blade.

Spiral Fin Elements: The metal sheath element is copper brazed with spiral fins then molded into a coil configuration. This combination produces the best heat transfer while eliminating the potential for hot spots by positioning the element in the maximum airflow stream.

Totally Enclosed Fan Motor: Permanently lubricated long life, unit bearing with 20cc of oil. Epoxy-coated motor with enclosed rotor resists moisture and corrosion for long-lasting, trouble-free operation.

Aluminum Fan Blade: Axial flow-type fan mounted directly to the motor shaft for maximum efficiency.

Thermal Overload: Heaters shall be equipped with King's patented thermal overload Smart Limit Protection®, which disconnects elements and motor in the event normal operating temperatures are exceeded. If thermal overload trips due to abnormal operating temperatures, thermal overload shall remain open until manually reset by turning the heater off for 15 minutes. Automatically reset of thermal overloads, which allow the element to continue to cycle under abnormal conditions, will not be accepted.

Cord Length: 6 Foot SO Cord (No Plug Provided)

Approvals: cETLus (517271) & (30314521)

Options/Accessories

ADD SUFFIX	DESCRIPTION
-25C	25 foot cord option

Dimensional Data

HEATER SIZE	DIMENSIONS						
	L1	L2	L3	W	H1	H2	H3
A	13½"	17"	1"	19"	14¼"	30¼"	41¼"
B	18"	21½"	1"	19"	14¼"	30¼"	41¼"
C	24"	21½"	1"	19"	14¼"	30¼"	41¼"

Minimum Clearance

front.....	3 ft.
top.....	1 ft.
sides.....	1 ft.
rear.....	1 ft.

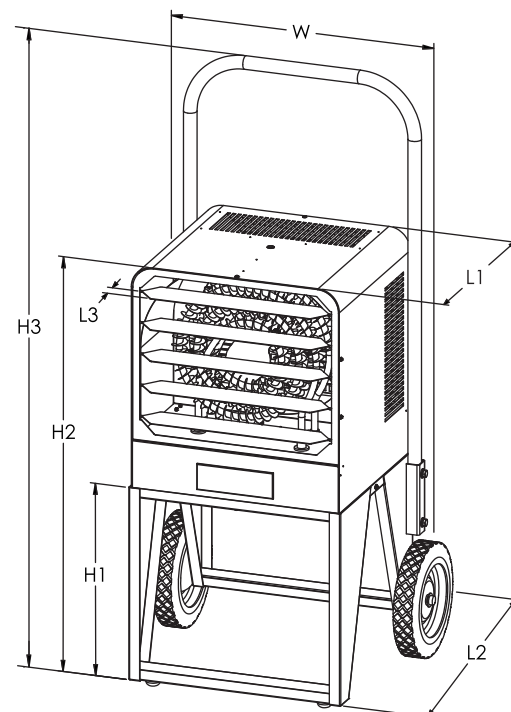

Industrial Portable Unit Heater PCK Series



Model Code:

PCK 48 20 -3 -T -DT -YJ
A B C D E F G

A: Series
B: 20 - 208V, 24 - 240V
48-480V
C: kiloWatts (10 - 30)
D: -1 = Single Phase
-3 = Three Phase
E: -T = Thermostat
G: -YJ = Yellow Jacket



- Built-in thermostat
- 24V control for heat or fan only
- steel spiral finned elements
- Long life 3R cast iron motor
- N.E.M.A. 12" gasket construction
- 12" duct transition
- Convenient carrying handles
- Optional frame
- Outdoor rating optional
- High visibility Yellow Jacket high tensile 18GA steel enclosure
- Large capacity dual-inlet blower handles high static pressure & moves large air volumes (1500 CFM)
- 95 lbs. without frame, 125 lbs. with industrial frame

PCK Industrial Portable Unit Heater

The King PCK "Yellow Jacket" Industrial portable unit heater is constructed to hold up to the rigorous demands of a jobsite or industrial facility. This unit heater is the very BEST heat source to assist in complete "Dry-out" applications, where dry electric heat is preferred to propane or kerosene space heaters. In addition, electric heat omits absolutely no odor, flame or carbon monoxide. The high CFM and moderate temperature rise are also key features to make this unit heater the very best solution for temporary large capacity heating and dry-out applications. Comes standard with a 12" collar for adding a flexible duct to extend the heated air to where it is needed. The -IF (Industrial Frame) complies with the FAA's Airport regulations of 18 inch above the ground for air inlet of the heater to reduce the jet fuel vapor being drawn in. An Outdoor rain proof rating can be added to the portable unit heater by adding the -OR (Outdoor Rating) to the Model number. This will allow you to place the heater outside in the rain and feed heated air into a building structure, plane, container, apartment, ship or any work area requiring heated dry fresh air and not take up space in the work area. The -OR option adds an intake rain baffle and electrical compartment rain cover and is UL approved for Outdoor Use. Many options are available. We can build one for your application.

Ordering Information

	MODEL	UPC	kiloWATTS	VOLTS	PHASE
208V	PCK2010-1	22186	10	208	1
	PCK2010-3	22187	10	208	3
	PCK2015-1	22188	15	208	1
	PCK2015-3	22189	15	208	3
	PCK2020-3	22190	20	208	3
	PCK2025-3	22191	25	208	3
	PCK2030-3	22192	30	208	3
240V	PCK2410-1	22193	10	240	1
	PCK2410-3	22194	10	240	3
	PCK2415-1	22195	15	240	1
	PCK2415-3	22196	15	240	3
	PCK2420-3	22197	20	240	3
	PCK2425-3	22198	25	240	3
	PCK2430-3	22199	30	240	3
480V	PCK4810-3	22200	10	480	3
	PCK4815-3	22201	15	480	3
	PCK4820-3	22202	20	480	3
	PCK4825-3	22203	25	480	3
	PCK4830-3	22204	30	480	3

Accessories

MODEL	UPC	DESCRIPTION
PCK-IF	22205	HEAVY DUTY INDUSTRIAL STEEL FRAME
PCK-IFCS	22206	CORD STORAGE SHELF
PCK-OR	22207	OUTDOOR RATING INLET RAIN BAFFLE W/ ELECTRICAL AND CORD COVER
RT100	22208	REMOTE THERMOSTAT W/100 FT. CORD

Optional heavy duty 1" x 2" steel frame for protection, convenient stackable storage and mobility from job site to job site.

Industrial Portable Unit Heater PCK Series



Shown with industrial steel frame and cord storage tray

Dimensional Data

#	QUANTITY	DESCRIPTION
1	4	1 X 2 X 39 Rect. tubing
2	2	1 X 2 X 28 Rect. tubing
4	4	1 X 2 X 16-3/8 Rect. tubing
5	2	1 X 2 X 18-3/8 Rect. tubing
3	2	2 X 2 X 30 Angle

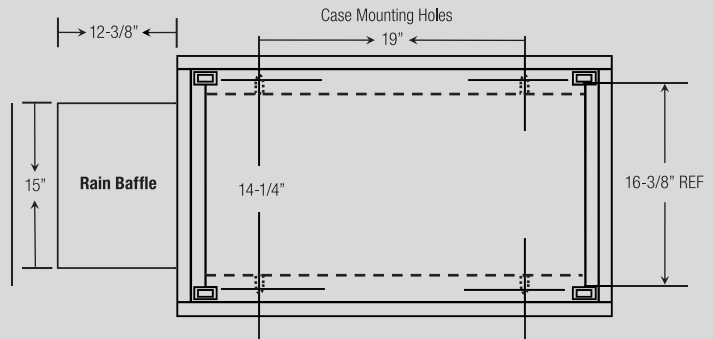
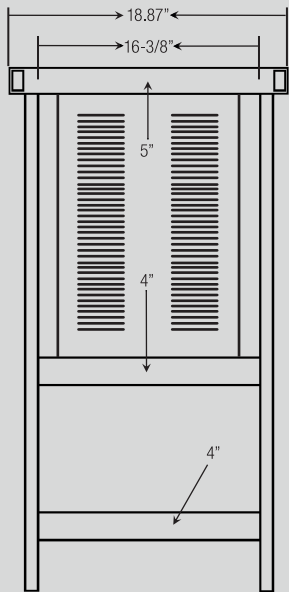
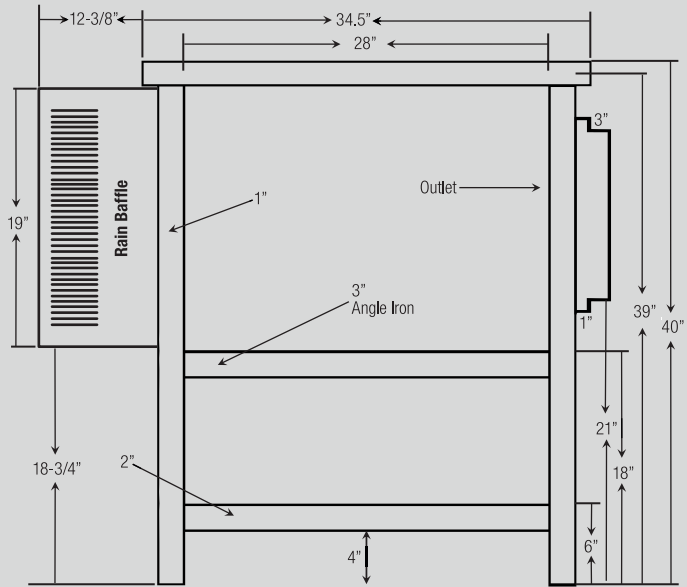

Shown with ducting



Shown with short steel frame 25-1/2"



Outdoor rating inlet rain baffle with electrical and cord cover

Electric Furnace KF/KFS Series



Model Code:

KF/KFS	20	20	1
A	B	C	D
A: Series			
B: 20 - 208V 24 - 240V 48 - 480V			
C: Kilowatts			
D: 1 or 3-phase			



- Heavy duty open-coil element
- Direct drive motor
- Up to 3-speed motor
- Standard 24 Volt control
- Horizontal or vertical mount
- Insulated discharge cabinet
- Baked enamel finish
- Fan relay
- Silent contactors
- Sequenced elements
- Dual inlet blower
- 60 Amp disconnect protection (KFS)
- Manual reset limit on 20 kW and larger
- Welded galvanized steel construction
- Thermally protected motor
- Replaceable filter
- Mobile home approved
- 5 Year limited warranty



The KFS Series Electric Furnace

The KFS Series furnace is the quietest and most compact unit available in its class. Ideal for residential applications, and yet powerful enough for commercial and process heating applications as well. It's the perfect choice for both new and replacement installations. The compact design allows it to be installed in either upflow, downflow or horizontal applications. Featuring a maintenance free blower, an insulated cabinet for quiet operation, and heavy gauge coiled nickel-chromium wire heating elements, the KFS furnace will provide years of trouble-free operation.

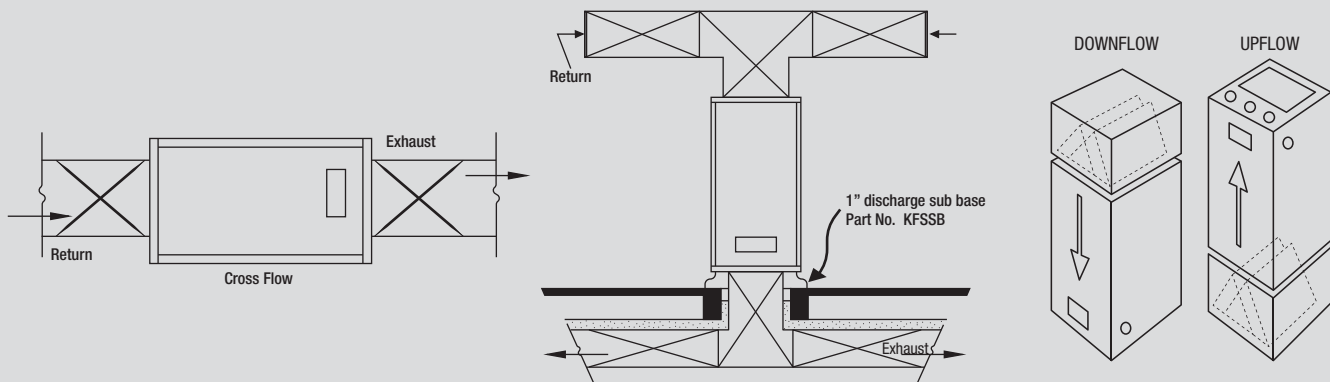

Engineering Specifications

Contractor shall supply and install KFS Series electric furnaces manufactured by King Electrical Mfg. Company. Furnaces shall be of the wattage and voltage as indicated on the plans.

Transformer: Each furnace is equipped with a heavy-duty low voltage (24 Volt) transformer for the thermostat control circuit.

Contactors or Time Delay Sequencer: Actuates heating element banks at random intervals to minimize electrical surges in compliance with E.E.I. and N.E.M.A. standards.

Heating Elements: Quick heating, long life Ni-Chrome elements are sized to provide proper watt density for maximum heat dissipation by fan-forced air convection currents.

Terminal Block: For field wiring (optional special order) KFSTB

Air Filter: Convenient access for replacement of standard 16" x 20" x 1" filter.

Overcurrent Protection: 208 and 240 volt KFS models have 60 amp circuit breakers. 480, 208 and 240 volt KF models have terminal blocks. Internal 60 amp fusing is provided for KF models over 48 amps.

Limit Control: Integral automatic high temperature limit control in each heating element bank prevents the delivery of air at unsafe temperatures. 20-35 kW use a manual reset limit control to completely shut the furnace off should an over temperature occur.

Fan Relay: Heavy-duty dual speed fan relay is standard with furnaces for air conditioning or summer fan operation.

Low Voltage Terminal Block: 24 Volt control screw terminals

Approvals: UL (E48864)

Electric Furnace KF/KFS Series

Dimensional Data

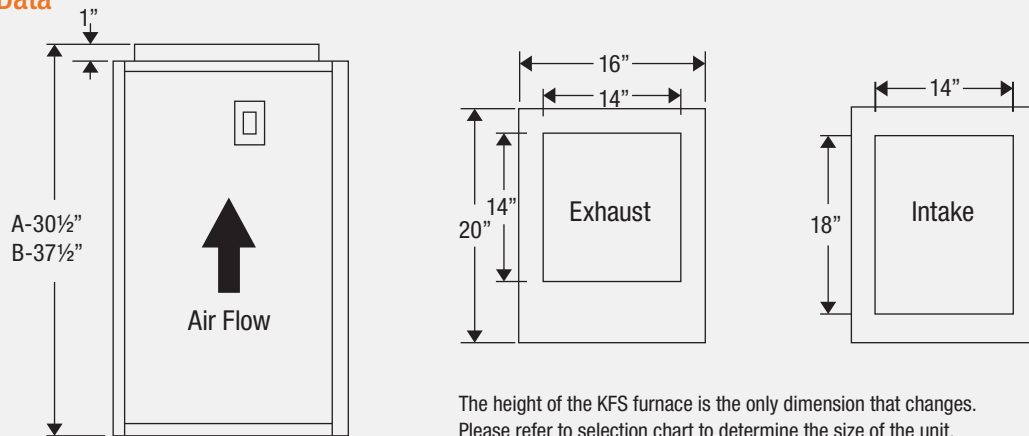

The height of the KFS furnace is the only dimension that changes. Please refer to selection chart to determine the size of the unit.

Accessories

MODEL	UPC	DESCRIPTION	WEIGHT(lbs.)
KFS-4PJB	20185	* 4-Pole Jumper Bar - 15kW to 20kW	.05
KFS-6PJB	20184	* 6-Pole Jumper Bar - 25kW to 30kW	.05
KFSSB	20182	1" discharge sub base	5
KFS-Q02C	20181	Small Cooling Cabinet 16" L x 22" W x 19 1/2" H - 13 lbs.	25
KFS-Q03C	20180	Large Cooling Cabinet 18" L x 22" W x 19 1/2" H - 15 lbs.	25
KFS-DT	20186	Transition from 14" x 14" Outlet to 12" round	25

* For single strike connection

DIMENSIONAL CLEARANCE

Cabinet Sides	1 in.
Cabinet Front	0 in.
Exhaust duct within 3 feet of furnace	1 in.
Return Air Plenum	0 in.

Options

ADD SUFFIX:	DESCRIPTION
-JB	15 kW to 30 kW, 1-Phase
-1/3HP	1/3 HP Motor & Blower - 3 kW to 18 kW
-1/2HP	1/2 HP Motor & Blower - 3 kW to 35 kW
-2S1	Two Stage Control, 1-Phase Models (see quick selection guide)
-2S3	Two Stage Control, 3-Phase Models (5 kW increments only)
*-3S1	Three Stage Control, 1-Phase Models
-1/5 ECM	1/5 hp Electronically Controlled Motor
-1/3 ECM	1/3 hp Electronically Controlled Motor

Factory Installed Options

ADD SUFFIX:	DESCRIPTION
-DS40	40 Amp, 3-Pole Disconnect Switch w/ Padlock Provision
-DS60	60 Amp, 3-Pole Disconnect Switch w/ Padlock Provision
-DS80	80 Amp, 3-Pole Disconnect Switch w/ Padlock Provision

Air Flow Chart

CASE SIZE	HP	SPEED	CFM (STATIC)							
			0.1	0.2	0.3	0.4	0.5	0.6	0.7	0.8
Small Case 30.5" tall	1/5	LOW	1090	980	940	890	840	920	800	760
		MED	1260	1090	1040	980	930	890	810	780
		HIGH	1370	1260	1220	1170	1120	1090	1080	990
	1/3	LOW	1700	1680	1670	1660	1650	1640	1630	1620
		MED	1810	1800	1790	1750	1740	1730	1720	1710
		HIGH	1960	1940	1930	1910	1870	1860	1850	1830
Large Case 37.5" tall	1/5	LOW	1160	1120	1090	1050	1020	990	960	850
		MED	1310	1230	1200	1150	1120	1050	990	910
		HIGH	1480	1410	1390	1270	1240	1180	1120	1040
	1/3	LOW	1860	1850	1840	1830	1820	1810	1790	1740
		MED	2000	1980	1960	1940	1930	1920	1910	1900
		HIGH	2120	2100	2070	2050	2030	2020	2010	2000

Electric Furnace KF/KFS Series

Internal Diagram - *exploded view*

Smart Heating Solutions

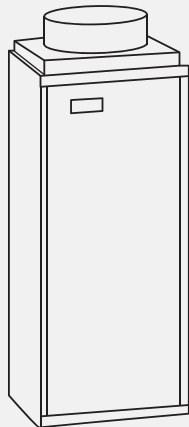

12" Round KFS-DT
Duct Transition

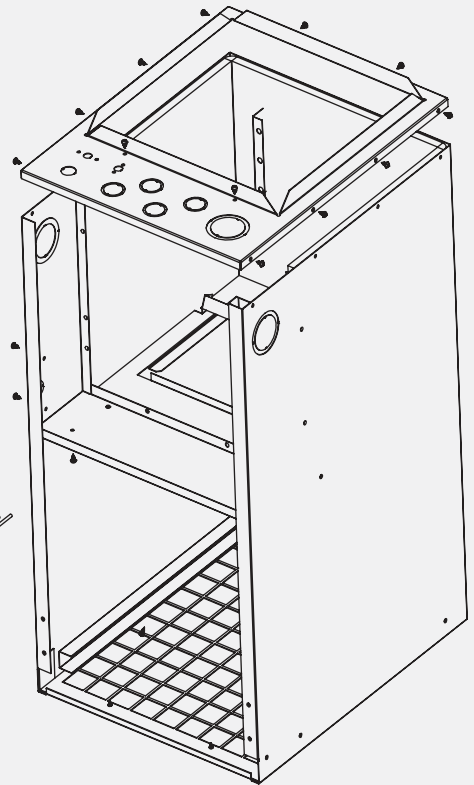

Heating Elements

Transformer

Each furnace is equipped with a 40VA low voltage (24 volt) transformer for the thermostat control circuit.

Low Voltage Terminal Block

Comes standard. With aux 24V access for dampers & air conditioning

Heating Elements

Quick heating long life nichrome elements are sized to provide proper watt density for maximum heat dissipation by fan forced air convection currents

Terminal Block

For Field Wiring (Optional Special Order)
For single strike

Fan Relay

Heavy duty dual speed fan relay comes standard with furnaces for air conditioning or summer fan

Time Delay / Contactor Sequencer

Actuates heating element banks at random intervals to minimize electrical surges in compliance with EEI and NEMA standards.

Limit Control

Integral automatic high temperature limit control in each heating element bank prevents the delivery of air at unsafe temperatures. 20-35 KW also use a manual reset limit control to completely shut the furnace off should an overtemperature condition occur.

Jumper Bar

for circuit breaker-JB

KF Model

has terminal block only, used when total current is under 48 amps.

Overcurrent Protection

60 Amp circuit breakers may be built in to comply with code requirements and offer ultimate safety in overcurrent protection. Front mounted for easy reset. Multiple circuits or single power source points

Motor

Long life thermally protected, permanently lubricated, direct drive motor - no belts to adjust or slip. This low noise three speed motor is designed for use with air conditioning capability as well as heating.

Air Filter

Convenient access for replacement of standard 16" x 20" x 1"
Do not use pleated filters.

Electric Furnace KF/KFS Series

Ordering Information

MODEL	PHASE	KILO WATTS	BTU (000)	VOLTS	*AMPS	CIRCUIT PROTECTION				75°C WIRE SIZING				# OF ELEMENTS	MOTOR		TEMPERATURE RISE			HEIGHT	WT. (lbs)
						L1 L2	L3 L4	L5 L6	L7 L8	L1 L2	L3 L4	L5 L6	L7 L8		VOLTS	HP	LOW	MED.	HIGH		
KFS2003-1	1	3	10.2	208	17.8	20				#10				1	208	1/5	12°	11°	9°	30½"	57
KFS2404-1	1	4	13.6	240	20	20				#10				1	240	1/5	16°	15°	13°	30½"	57
KFS2005-1	1	5	17.1	208	27.2	40				#8				1	208	1/5	20°	18°	16°	30½"	57
KFS2405-1	1	5	17.1	240	24.2	30				#10				1	240	1/5	20°	18°	16°	30½"	57
KF4805-1	1	5	17.1	480	12.1	15				#14				1	480	1/5	20°	18°	16°	30½"	57
KFS2006-1	1	6	20.5	208	32.2	40				#8				2	208	1/5	24°	22°	19°	30½"	57
KFS2408-1	1	8	27.3	240	37	50				#6				2	240	1/5	32°	30°	25°	30½"	65
KFS2010-1	1	10	34.1	208	51.4	30	40			#6				2	208	1/5	41°	37°	32°	30½"	65
KFS2410-1	1	10	34.1	240	45	60				#6				2	240	1/5	41°	37°	32°	30½"	65
KF4810-1	1	10	34.1	480	22.5	30				#10				2	480	1/5	41°	37°	32°	30½"	65
KFS2412-1	1	11.5	39.2	240	51.3	40	30			#8	#10			2	240	1/5	47°	42°	36°	30½"	65
KF4812-1	1	11.5	39.2	480	25.7	40				#8				2	480	1/5	47°	42°	36°	30½"	65
KFS2015-1	1	15	51.2	208	75.5	40	60			#8	#6			3	208	1/5	61°	55°	47°	30½"	74
KFS2415-1	1	15	51.2	240	65.9	30	60			#10	#6			3	240	1/5	61°	55°	47°	30½"	74
KF4815-1	1	15	51.2	480	32.9	50				#6				3	480	1/5	61°	55°	47°	30½"	74
KFS2418-1	1	17.25	58.8	240	75.2	40	60			#8	#6			3	240	1/5	70°	63°	55°	30½"	74
KF4818-1	1	17.25	58.8	480	37.6	50				#6				3	480	1/5	70°	63°	55°	30½"	74
KFS2020A-1	1	20	68.3	208	99.5	60	60			#6	#6			4	208	1/5	81°	73°	63°	37½"	76
KFS2420A-1	1	20	68.3	240	86.7	60	60			#6	#6			4	240	1/5	81°	73°	63°	37½"	76
KF4820A-1	1	20	68.3	480	43.4	60				#6				4	480	1/5	81°	73°	63°	37½"	76
KFS2020-1	1	20	68.3	208	99.4	60	60			#6	#6			4	208	1/3	57°	51°	41°	37½"	76
KFS2420-1	1	20	68.3	240	86.5	60	60			#6	#6			4	240	1/3	57°	51°	41°	37½"	76
KF4820-1	1	20	68.3	480	43.4	60				#6				4	480	1/3	57°	51°	41°	37½"	76
KFS2422-1	1	22.5	76.8	240	96.9	60	60			#6	#6			4	240	1/3	57°	51°	41°	37½"	76
KF4822-1	1	22.5	76.8	480	48.6	60				#6				4	480	1/3	57°	51°	41°	37½"	76
KFS2025-1	1	25	85.3	208	123.4	30	60	60		#10	#6	#6		5	208	1/3	72°	63°	51°	37½"	81
KFS2425-1	1	25	85.3	240	107.4	30	60	60		#10	#6	#6		5	240	1/3	72°	63°	51°	37½"	81
KF4825-1	1	25	85.3	480	53.8	20	60			#12	#6			5	480	1/3	72°	63°	51°	37½"	81
KFS2030-1	1	30	102.4	208	147.4	60	60	60		#6	#6	#6		6	208	1/3	86°	76°	62°	37½"	85
KFS2430-1	1	30	102.4	240	128.2	60	60	60		#6	#6	#6		6	240	1/3	86°	76°	62°	37½"	85
KF4830-1	1	30	102.4	480	65.7	30	60			#10	#6			6	480	1/3	86°	76°	62°	37½"	85
KFS2435-1	1	34.5	117.7	240	146.9	15	60	60	60	#14	#6	#6	#6	6	240	1/3	99°	87°	71°	37½"	85
KF4835-1	1	34.5	117.7	480	73.6	40	60			#8	#6			6	480	1/3	99°	87°	71°	37½"	85

MODEL	PHASE	KILO WATTS	BTU (000)	VOLTS	*AMPS	CIRCUIT PROTECTION			75°C WIRE SIZING			# OF ELEMENTS	MOTOR		TEMPERATURE RISE			HEIGHT	WT. (lbs)	
						L1 / L2 / L3	L1 / L2 / L3	L1 / L2 / L3	L1 / L2 / L3	L1 / L2 / L3	VOLTS		HP	LOW	MED.	HIGH				
KFS2405-3	3	5	17.1	240	15.4	20				#12			1	240	1/5	20°	18°	16°	30½"	57
KF4805-3	3	5	17.1	480	7.7	10				#14			1	480	1/5	20°	18°	16°	30½"	57
KFS2009-3	3	9	30.7	208	28.3	40				#8			3	208	1/5	37°	33°	28°	30½"	74
KFS2410-3	3	10	34.1	240	27.4	40				#8			2	240	1/5	41°	37°	32°	30½"	74
KF4810-3	3	10	34.1	480	13.7	20				#12			2	480	1/5	41°	37°	32°	30½"	74
KFS2012-3	3	11.25	38.4	208	34.6	40				#8			3	208	1/5	46°	41°	35°	30½"	74
KFS2412-3	3	12	40.9	240	32.3	40				#8			3	240	1/5	47°	42°	36°	30½"	74
KF4812-3	3	12	40.9	480	16.1	20				#12			3	480	1/5	47°	55°	36°	30½"	74
KFS2015-3	3	15	51.2	208	43.5	60				#6			3	208	1/5	61°	55°	47°	30½"	74
KFS2415-3	3	15	51.2	240	45	50				#6			3	240	1/5	61°	55°	47°	30½"	74
KF4815-3	3	15	51.2	480	21.4	30				#10			3	480	1/5	61°	63°	47°	30½"	74
KFS2418-3	3	17.25	58.8	240	44.8	60				#6			3	240	1/5	70°	63°	55°	30½"	74
KF4818-3	3	17.25	58.8	480	22.4	40				#8			3	480	1/5	70°	51°	55°	30½"	74
KFS2420-3	3	20	68.3	240	51.3	70				#6			4	240	1/3	57°	51°	41°	37½"	76
KF4820-3	3	20	68.3	480	25.7	30				#12			4	480	1/3	57°	56°	41°	37½"	74
KFS2022-3	3	22.5	76.8	208	65.5	100				#3			6	208	1/3	64°	61°	46°	37½"	85
KFS2424-3	3	24	81.6	240	60.9	75				#4			6	240	1/3	69°	61°	49°	37½"	85
KF4824-3	3	24	81.6	480	30.5	50				#6			6	480	1/3	69°	63°	49°	37½"	85
KFS2425-3	3	25	85.3	240	63	75				#4			5	240	1/3	72°	63°	51°	37½"	85
KF4825-3	3	25	85.3	480	32	50				#6			5	480	1/3	72°	76°	51°	37½"	85
KFS2030-3	3	30	102.4	208	86.5	110				#2			6	208	1/3	86°	76°	62°	37½"	85
KFS2430-3	3	30	102.4	240	75.3	100				#3			6	240	1/3	86°	76°	62°	37½"	85
KF4830-3	3	30	102.4	480	37.3	50				#6			6	480	1/3	86°	76°	62°	37½"	85
KFS2435-3	3	34.5	117.7	240	86.2	110				#2			6	240	1/3	99°	87°	71°	37½"	85
KF4835-3	3	34.5	117.7	480	43	60				#6			6	480	1/3	99°	87°	71°	37½"	85

Electric Furnace KF/KFS Series

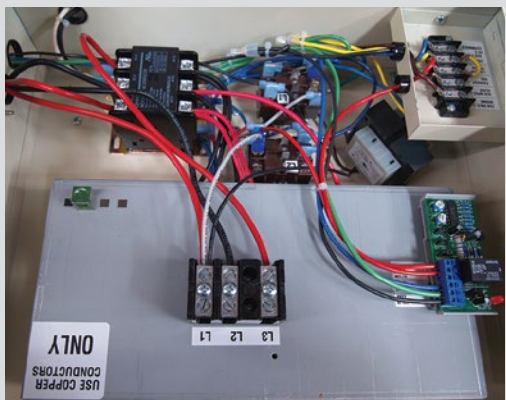

Factory Installed Options

ADD SUFFIX:	DESCRIPTION
-SCR45-1	SCR Fully Modulating Fan Coil Unit, 45 Amp, 1-Phase
-SCR45-3	SCR Fully Modulating Fan Coil Unit, 45 Amp, 3-Phase
-SCR45X2-1	SCR Fully Modulating Fan Coil Unit, 90 Amp, 1-Phase
-SCR45X2-3	SCR Fully Modulating Fan Coil Unit, 90 Amp, 3-Phase

Additional Add-On Options

ADD SUFFIX:	DESCRIPTION
-MT	Modulating Thermostat
-DS	Duct Sensor Temperature Provision
-AF	Air Flow Switch Provision (Air Flow Switch Purchased Separately)

SCR Fully Modulating Fan Coil Unit



SCR Power Control



Fan Control Transducer

- SCR Power Control provides precise modulation of the electric resistance heating load. Available for 208V, 240V, 480V 1-phase and 3-Phase. Amp rating: 45A and 75A or 90A (2x45A units). Accepts 4 – 20 mA or 0-10 VDC input signal Includes LED indication light.
- Fan Control Transducer accepts 4 – 20 mA or 0-10 VDC input signal to produce a single-stage relay output.
- Selectable 3-Speed Fan is set up at installation to provide the required CFM.

Optional Components for Modulating Fan Coil Unit



Modulating Thermostat



Duct Temperature Sensor



ECM Motor

- Modulating Thermostat with 0 to 10VDC modulating output controls the output temperature by modulating directly to the SCR power controller. Can be mounted remotely or on the unit for make up air applications.
- Duct Temperature Sensor is used with the modulating thermostat and is mounted on the discharge side unit to precisely control the air temperature. Controls discharge air temperature regardless of the incoming air temperature typical of make up air applications.
- Air Flow Switch Provision Terminals (Air Flow Switch Purchased Separately) to be interlocked with the unit so that the heating coils do not energize without airflow detected.
- Optional ECM Motor for multiple speed control.

Electric Furnace KFS endura^{PRO}



Model Code:

KFS	24	20	1	2S1	ECM
A	B	C	D	E	F

A: Series
 B: 24 - 240V
 C: Kilowatts
 D: 1-phase
 E: 2 Stage
 F: ECM Motor



- Energy efficient motor
- 2 stage comfort heating 15% savings
- Down flow or up flow
- Sequenced heating elements
- Quiet sound insulated cabinet
- 16" x 20" x 1" inlet filter
- Welded cabinet design
- Horizontal or vertical mount
- Mobile home approved
- Breaker disconnects
- Baked enamel finish
- Extended life
- 24 Volt control
- Fan only relay
- 5 Year limited warranty



The KFSendura^{PRO}

ENERGY SAVINGS meets MAXIMUM COMFORT with the ENDURA PRO ECM Motor & 2 Stage Heating
 The Endura Pro Model adds a state of the art electronically controlled motor and 2 heating stages for added comfort and Maximum Energy Savings. Quiet operation and Multi-position mounting allows you to put it almost anywhere it will fit. Whether it is commercial, residential or process heating, this air furnace will do the job and give years of excellent maintenance-free service.

Motor Features

- Energy Saver
- AFUE 100% (Energy Guide Rating) Most Efficient
- 3 speeds available
- Designed for extended life
- Efficiency up to 80%
- 60 second time delay
- Up to 33% greater efficiency with Endura Pro motor
- Up to 200% greater efficiency with Endura Pro motor in constant fan mode

Heating Features

- 2-Stage Elements & control
- Ni-Chrome Elements
- More even heating

endura^{PRO}

Trademark of Genteq®

Engineering Specifications

Contractor shall supply and install KFS Series electric furnaces manufactured by King Electrical Mfg. Company. Furnaces shall be of the wattage and voltage as indicated on the plans.

Transformer: Each furnace is equipped with a heavy duty low voltage (40 VA) transformer for the thermostat control circuit.

Time Delay Sequencer: Actuates heating element banks to minimize electrical surges in compliance with E.E.I. and N.E.M.A. standards.

Heating Elements: Quick heating, long life Ni-Chrome elements are sized to provide proper watt density for maximum heat dissipation.

Terminal Block: For field wiring (optional special order) KFSTB Single Strike Connection. Takes multiple circuits into a single feed.

Air Filter: Convenient access for replacement of standard 16" x 20" x 1" filter. Do not use pleated filters.

Motor: Energy Saving, Long life, thermally protected, permanently lubricated, direct drive Endura Pro motor—no belts to adjust or slip. This low noise, 3 speed motor is designed for use with air conditioning capability as well as heating. Very quiet operating. 60 second fan delay.

Overcurrent Protection: 208 and 240 volt KFS models have 60 amp circuit breakers. 480, 208 and 240 volt KF models have terminal blocks. Internal 60 amp fusing is provided for KF models over 48 amps.

Limit Control: Integral automatic high temperature limit control in each heating element bank prevents the delivery of air at unsafe temperatures. 20-35 KW models use a manual reset limit control to completely shut the furnace off should an unsafe temperature occur. Summer fan only operation. Fan can be run independently from heating. Mobile Home approved.

Unique Fan Orifice: Louver directs air over all heating elements and side walls evenly ensuring longer life performance.

Low Voltage Terminal Block: 24 Volt control screw terminals.

Approvals: cULus (E48864) USA and Canada

Electric Furnace KFS endura^{pro}

Ordering Information Refer to model KFS for dimensions

MODEL	VOLTS	PHASE	STAGE 1	STAGE 2	WATTAGE	BTU	WIRES	AMPS
KFS2408-1-2S1-ECM	240V	-1Ph	4 kW	4 kW	8 kW	27.3	#6/2	37
KFS2410-1-2S1-ECM	240V	-1Ph	5 kW	5 kW	10 kW	34.1	#6/2	45
KFS2412-1-2S1-ECM	240V	-1Ph	5.75 kW	5.75 kW	11.5 kW	39.2	#8/2- #10/2	51.3
KFS2415-1-2S1-ECM	240V	-1Ph	5 kW	10 kW	15 kW	51.2	#6/2- #10/2	65.9
KFS2418-1-2S1-ECM	240V	-1Ph	5.75 kW	11.5	18 kW	58.8	#8/2- #6/2	75.2
KFS2420-1-2S1-ECM	240V	-1Ph	10 kW	10 kW	20 kW	68.3	#6/2- #6/2	86
KFS2425-1-2S1-ECM	240V	-1Ph	15kW	10 kW	25 kW	85.3	#6/2-#6/2-#10/2	107
KFS2430-1-2S1-ECM	240V	-1Ph	15 kW	15kW	30 kW	102.4	#6/2-#6/2- #6/2	128.2

TWO STAGE COMFORT *Why 2 Stage is Better*

2 Stage controlled Furnaces allow you to use less energy during mild Spring and Fall temperatures. It's like having a smaller furnace installed just for spring and fall, then when winter hits you have the reserve power of the second heating stage to fight off the cold weather. It also has the benefit of creating more even comfort temperatures.

Note: *The Furnace will run a percentage longer to reach the room temperature so the Endura Pro motors efficiency is key to getting the most out of your Furnace.*

Two Stage Comfort

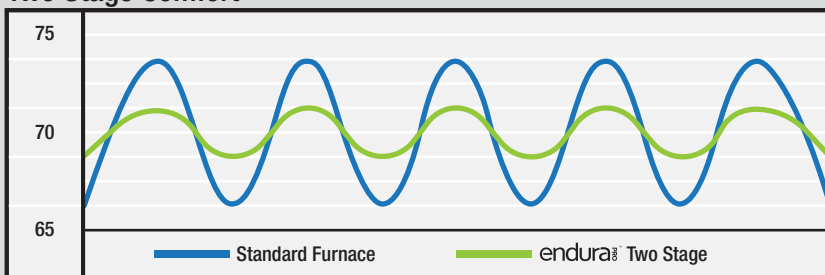

Yearly Savings

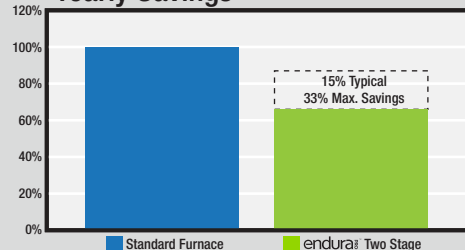

The Endura Pro is more efficient and will save you up to 33% more per year versus standard furnace motors

- Designed for extended life
- Energy efficient
- Improved reliability
- Cooler operating temperature
- 3 speeds
- 15% 2 Stage

This Model's Efficiency
100.0 AFUE

Energy efficiency range of all similar models

Least Efficient **100.0** Most Efficient **100.0**



Air Flow Chart

FURNACE SIZE	BLOWER WIDTH	24 VOLT MOTOR TERMINAL	CFM (STATIC)							
			0.1	0.2	0.3	0.4	0.5	0.6	0.7	0.8
Small (4-18 KW) 30.5" tall	9" 1/5 HP ECM Standard	1	1090	980	940	890	840	920	800	760
		2, 4	1260	1090	1040	980	930	890	810	780
		3, 5	1370	1260	1220	1170	1120	1090	1080	990
	10" 1/3 HP ECM Optional	1	1700	1680	1670	1660	1650	1640	1630	1620
		2, 4	1810	1800	1790	1750	1740	1730	1720	1710
		3, 5	1960	1940	1930	1910	1870	1860	1850	1830
Large (20-35 KW) 37.5" tall	9" (KFS2420A)	1	1160	1120	1090	1050	1020	990	960	850
		2, 4	1310	1230	1200	1150	1120	1050	990	910
		3, 5	1480	1410	1390	1270	1240	1180	1120	1040
	10" Standard	1	1860	1850	1840	1830	1820	1810	1790	1740
		2, 4	2000	1980	1960	1940	1930	1920	1910	1900
		3, 5	2120	2100	2070	2050	2030	2020	2010	2000

Air Filter Size: 16" x 20" x 1" on both furnace sizes



Model Code:

PAW	12	15	-SS	-ST
A	B	C	D	E

A: Series
B: Volts: 12=120V 20=208V 24=240V 27=277V
C: Watts (250 - 2250)
D: Stainless Steel
E: Slope Top



- 304 stainless steel enclosure
- Pic-A-Watt® Element
- Multiple wattages
- Flange-mount wall can
- Manual reset high limit
- C-Frame motor
- Squirrel cage blower
- Patented Smart Limit Protection®
- Whisper quiet
- Slope top
- Approved for inspected vessels
- 3-year limited warranty



The Stainless Steel PAW-SS Series

The heater of choice in the boating industry. This is the only electric heater specifically designed to be used in marine applications. It has all the great features of the Pic-A-Watt® heater (including a stainless steel grill, wall can and interior) enabling it to stand up to the corrosive environment on saltwater boats. The wall can is flanged for recess mounting into a wood bulkhead. Consult factory or review catalog for other models, including a high-efficiency motor and a Dial-A-Watt™ switch allowing you to change the wattage with a grill-mounted selector switch.

Ordering Information *Add suffix -ST for Slope Top Surface Can (required when surface-mounting on inspected vessels)

MODEL	UPC	VOLTS	WATTS	AMPS	SHIP WEIGHT lbs
PAW1215-SS	16315	120V	250•500•750•1000•1250•1500	2.1-12.5	9.5
PAW2022-SS	00516	208V	500•750•1000•1250•1500•1750•2250	2.4-10.8	9.5
PAW2422-SS	16313	240V	500•750•1000•1250•1500•1750•2250	2.1-9.4	9.5
PAW2720-SS	00518	277V	1000•2000	3.6-7.2	9.5

Engineering Specifications

Contractor shall supply and install PAW Stainless Steel Series in-wall mounted forced-air electric heaters manufactured by King Electrical Mfg. Company. Heaters shall be of the wattage and voltage as indicated on the plans.

Construction: The heater wall can and heat box assembly will be of 20 gauge 304 stainless steel and have a depth gauge label on top of the wall can. Flanges on each side of the wall can will aid in mounting to wooden bulkheads. All fasteners are stainless steel or nickel plated. If surface mounting on a inspected vessel an angled top can will be used.

Ratings: Heaters shall be available in wattages of 250 to 2,250 at 120, 208, 240, or 277 Volts.

Blower and Motor: A tangential cylindrical blower, delivering 65 CFM, shall be driven by a shaded pole, permanently lubricated, C-frame type motor with impedance protection and sealed bearings. Motors shall be the same voltage as the heater.

Elements: Element assemblies shall consist of three steel sheathed heating tubes in a furnace-brazed, plate-finned, block design. Each sheathed tube shall contain coiled Ni-Chrome wire embedded in an insulator of Magnesium Oxide. The element assembly shall provide up to seven (7) possible wattage configurations available for selection during field installation. The use of external resistors, diodes, or other weak links to obtain multiple wattages will not be accepted.

Thermal Overload: Heaters shall be equipped with King's patented thermal overload Smart Limit Protection®, which disconnects elements and motor in the event normal operating temperatures are exceeded. If thermal overload trips due to abnormal operating temperatures, thermal overload shall remain open until manually reset by turning the heater off for fifteen minutes. Automatic reset of thermal overloads, which allow the element to continue to cycle under abnormal conditions, will not be accepted.

Wall Can: The wall can shall be 20 gauge stainless steel and shall contain a minimum of three (3) knockouts through which power leads are brought. The wall can shall have a depth gauge or flange and a factory installed Copper ground-wire. Minimum 4" clearance to floors and 6" to sidewalls. Zero clearance to combustibles in wall.

Grill: The grill shall be a louvered, one-piece design with square corners on all four sides. The grill shall be clear epoxy powder-coated.

Approval: Heaters shall be listed and approved by Underwriters Laboratories or equal.

Stainless Steel PAW-SS Series

Options

ADD SUFFIX	DESCRIPTION
-ST	Adds slope top wall can. Required on inspected vessels.

Accessories

MODEL	UPC	DESCRIPTION	SHIP WEIGHT lbs
PAWF-SS	16318	Bulkhead Can with Flange - Stainless Steel. Inspected vessel.	2
PAWS-SS	16317	Surface Can - Stainless Steel	2
PAWG-SS	16330	Marine Grille - Stainless Steel	2
PT-1-SS	16309	Single Pole Thermostat Kit	0.5
PT-2-SS	16311	Double Pole Thermostat Kit	0.5

Dimensional Data

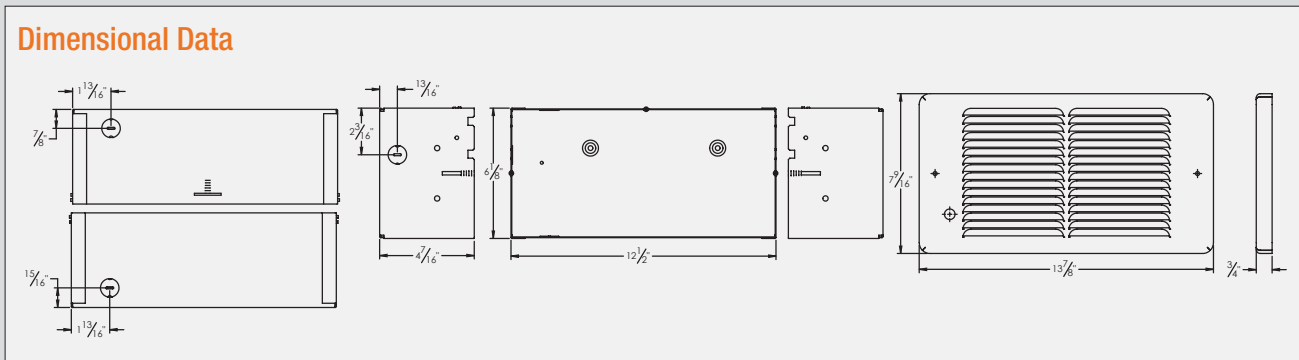

Also Available in a Slope-Top Surface Mounted Can



Intended for use on inspected vessels

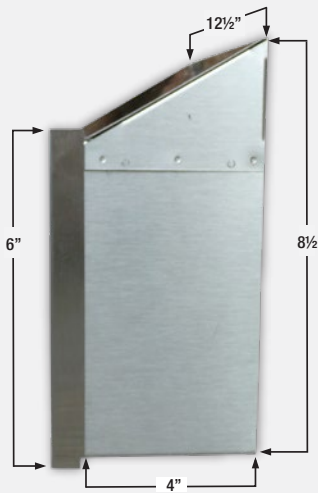

MINIMUM CLEARANCE

Zero clearance to insulation 4" above floor 6" from adjacent wall



Model Code:

DAW	12	15	-SS
A	B	C	D

A: Series
B: Volts: 12=120V 20=208V
 24=240V 27=277V
C: Watts (250 - 2250)
D: Stainless Steel



- Select from up to 7 wattages with switch on grill
- Pic-A-Watt® Element
- 304 Stainless Steel Enclosure
- C-Frame Motor
- Squirrel Cage Blower
- Whisper Quiet
- Green pilot light indicates heat is on
- 20 gauge clear powder-coated grill
- Multiple wattage selection
- Flange-mount wall can
- Smart Limit Protection®
- 1-Pole or 2-Pole unit mount thermostat 45° - 80°F
- 120, 208, or 240 Volts



The Stainless Steel DAW-SS Series

A heater unique to King featuring the ability to choose the wattage needed. A heavy-duty industrial switch mounted on the grill allows quick and easy choice of up to 7 different heat settings. Use where higher wattage is not required during unoccupied periods. Typical installations are toll booths, motor home/RVs, pleasure craft and cabins. By providing air movement and dry heat, musty, moldy odors are reduced and interior fabric life is maximized. Utilizing a lower wattage provides winter freeze protection with the bonus of energy savings. During RV use the heater load (Amperage) can be adjusted to the receptacle or cord size. This prevents damage to plugs and receptacles due to overloading. During lay-up periods, wattage can be adjusted to the correct level. Quiet operating tangential cylindrical (squirrel cage) blower and commercial grade element make the Dial-A-Watt™ the heater of choice for people on the move.

Ordering Information

MODEL	UPC	VOLTS	WATTS	AMPS	SHIP WEIGHT lbs
DAW1215-SS	19251	120	250•500•750•1000•1250•1500	2.1-12.5	9
DAW2022-SS	19208	208	500•750•1000•1250•1500•1750•2250	2.4-10.8	9
DAW2422-SS	19252	240	500•750•1000•1250•1500•1750•2250	2.1-9.4	9

Refer to Stainless Steel PAW Series for dimensions and accessories

Engineering Specifications

Contractor shall supply and install, DAW Stainless Steel Series wall mounted forced-air electric heaters manufactured by King Electrical Mfg. Company, of the wattage and voltage as indicated on the plans.

Ratings: Heaters shall be available in wattages of 250 to 2,250 at 120, 208, or 240 Volts.

Blower and Motor: A tangential cylindrical blower, delivering 65 CFM, shall be driven by a shaded pole, permanently lubricated, C-frame type motor with impedance protection and sealed bearings. Motors shall be the same voltage as the heater.

Elements: Element assemblies shall consist of steel sheathed heating tubes in a furnace brazed, plate-finned, block design. Each sheathed tube shall contain coiled a Ni-Chrome wire embedded in an insulator of Magnesium Oxide.

Thermal Overload: Heaters shall be equipped with thermal overload Smart Limit Protection®, which disconnects elements and motor in the event normal operating temperatures are exceeded. If thermal overload trips due to abnormal operating temperatures, thermal overload shall

remain open until manually reset by turning the heater off for fifteen minutes. Automatic reset of thermal overloads, which allow the element to continue to cycle under abnormal conditions, will not be accepted.

Wall Can: The wall can shall be stainless steel and shall contain a minimum of three (3) knockouts. The wall can shall have a depth gauge or flange mount, and a factory installed Copper groundwire. Minimum 4" clearance to floors and 6" to sidewalls. Zero clearance to combustibles in the wall.

Grill: 304 brushed stainless steel, clear powder coating.

Selector Switch: Shall provide up to 7 wattage settings adjustable from switch on front of heater.

Indicator: Light designates heater is operating.

Approval: Heaters shall be listed and approved by Underwriters Laboratories or equal.

Stainless Steel MKT-SS Series



Model Code:

MKT	12	10	-SS
A	B	C	D

A: Series
 B: Volts: 12=120V 20=208V
 24=240V
 C: Watts (375 - 1500)
 D: Stainless Steel



- 304 Stainless steel construction
- Low profile
- Open-coil element
- Squirrel cage blower
- C-Frame motor
- Stainless steel grill
- Overlap grill
- Patented Smart Limit Protection®
- 1-year limited warranty



The Stainless Steel MKT-SS Series

This low-profile kick space heater fits where standard heaters cannot. Stainless steel construction makes it ideally suited where corrosion resistance is needed such as marine vessels or other high humidity areas. A typical marine vessel application is mounting through a bulkhead or plywood cabinet. The oversize grill (photo) is standard. For under-counter applications check the accessories table for the appropriate grill.

Ordering Information

	MODEL	UPC	VOLTS	WATTS	AMPS	SHIP WEIGHT lbs
120V	MKT1210-SS	11007	120	1000 or 500	8.3 or 4.2	8
	MKT1215-SS	11014	120	1500 or 750	12.5 or 6.3	8
240V	MKT2410-SS	11001	240/208*	1000 or 500/750 or 375	4.2 or 2.1/3.2 or 1.6	8
	MKT2412-SS	11005	240/208*	1200 or 600/900 or 450	6.3 or 3.2/4.7 or 2.4	8
	MKT2415-SS	11008	240/208*	1200 or 600/900 or 450	5.0 or 2.5/4.3 or 1.9	8

*Dual rated heaters will draw 13% less amps and 25% less wattage when operated at 208V.

Refer to KT Series heater for dimensional data

Accessories

MODEL	UPC	DESCRIPTION	SHIP WEIGHT lbs
KTG-SS	12269	Stainless Steel Grill 4-1/2" (Surface)	1.0
MKT-1-SS	11010	Single Pole Single Throw Thermostat Kit	0.6
MKT-2-SS	11011	Double Pole single Throw Thermostat Kit	0.6
KTG-SS-3-1/2	12267	SS Grille Standard – 3-1/2" X 16-1/2" (No Overlap) (Recess)	1.1

Engineering Specifications

Contractor shall supply and install MKT Series limited space-mounted forced-air electric heaters manufactured by King Electrical Mfg. Company. Heaters shall be of the wattage and voltage as indicated on the plans.

Motor: Thermally protected and permanently lubricated.

Fan: Tangential (squirrel cage) blower provides whisper-quiet operation at 70 CFM.

Element: Dual wattage element allows for field adjustment. Made from Ni-Chrome alloy open-coil wire wrapped around a mica insulator.

Thermal Cutout: Safety limit turns off power to the element if it overheats and automatically resets.

Thermal Overload: Heaters shall be equipped with thermal overload Smart Limit Protection®, which disconnects elements and motor in the event normal operating temperatures are exceeded.

If thermal overload trips due to abnormal operating temperatures, thermal overload shall remain open until manually reset by turning the heater off for fifteen minutes. Automatic reset of thermal overloads, which allow the element to continue to cycle under abnormal conditions, will not be accepted.

Wall-box: 20 gauge type 304 brushed stainless steel. All fasteners and hardware are stainless steel. Zero clearance to floors and 6" to sidewalls. Zero clearance to combustibles.

Grill: 20 gauge 304 stainless steel, clear epoxy finish.

Options: 1-Pole or 2-Pole unit-mount thermostat 45 - 80°F operating range and overlap grill.

Electric Duct Heater R Series



- Commercial grade heating coil and rack
- Direct install to HVAC boot
- UL approved for zero-clearance installation (without insulation)
- Can also be used in fan mode to boost air conditioning
- Eliminates space heaters / wall-mounted units
- Improved heating efficiency (point of use)
- Maintains consistent comfort level
- Minimal heat loss
- Easy to install

The Heat Pack In-Line Duct Heating System

The R Series is used anywhere extra heating capacity is needed. Designed for residential and commercial applications on 6" diameter ducts. The R series heat pack improves heating system balance problems. Comes with an integral axial fan which produces approximately 160 CFM during operation and is intended for use with either a remote wireless or wired thermostat, to be wall mounted inside the heated room.



Easy to install

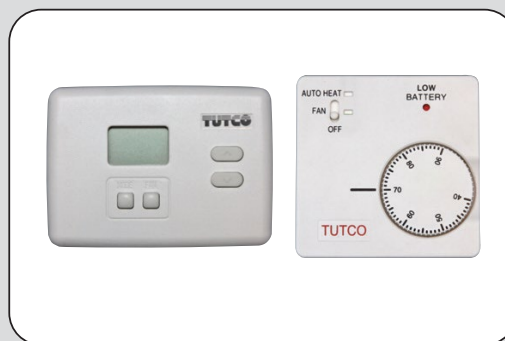

Wired or wireless thermostat options

Engineering Specifications

Composition and Materials: All sheet metal housing. 0.034+/.008/-0.00 minimum spangle galvanized sheet steel grade G-90.

Accessory Options: Standard supply voltages from 120-1440 & Standard control voltages from 120-277 single or three phase heaters, Slip In or Flange mounted, Recessed control box, right handed offset control box, 80/20 (Ni/Cr) resistance wire, Stainless steel terminals, Derated coils, vapor barrier and gasketed cover.

Standard Features: Direct install to HVAC boot or existing ductwork, commercial grade heating coil and rack, UL approved for zero-clearance installation without additional insulation, wired or wireless thermostat, custom Hanger system, Insulated unit and triple safety protection.

Applications: Bathrooms, bedrooms, nurseries, garages/attics, sunrooms, offices, lobbies, under floor systems and workshops.

Approvals: cULus, ETL, UL International

Flippable Electric Duct Heater E Series



- Patent pending flippable design
- Can be installed 6 different ways
- Better heater coverage
- Lower coil watt density
- Integration with VAV single duct valves and controls
- Design program offers wider distribution of kilowatt sizes
- Solid state relay controls
- Heats large volumes of air with fast warm-ups and cool-downs
- Our open design provides low pressure drops with no build up of excessive temperatures and the low static pressures allow you to use smaller, more economical blowers
- Available in voltages up to 600 volts: single and three phase
- Two frame types are available: slip in and flange.

The E Series Flippable Duct Heater

EVH and EDH, products, brings innovation and flexibility to the electric duct heater and variable air volume, (VAV), heater markets. Both series include symmetrical design features that provide flexibility during installation at a project or work site. Duct heaters are used in forced air applications to provide standalone space heat or to supplement existing heating systems. Installation examples include space heating, primary heating, reheating, multi-zone or VAV, Replacement of existing and secondary/auxiliary heating. All models may be flipped and rotated as long as the diffuser/radiant screen is moved to the inlet air side where applicable.

For EVH Models:

Minimum air velocity is 70 CFM per KW (75-80 recommended)
 Maximum inlet air temp is 100 degrees F°
 Maximum heater KW is 16.5 KW per ft² of duct cross section.

For EDH Models:

Minimum air velocity is 70 CFM per KW (75-80 recommended)
 Maximum inlet air temp is 100 degrees F°
 Maximum heater KW is 18 KW per ft² of duct cross section.

Engineering Specifications

Composition and Materials: All sheet metal housing. 0.034+.008/-0.00 minimum spangle galvanized sheet steel grade G-90.

Standard Features: Open-coil element, airflow switch, detailed wiring diagram, Control terminal board and Grounding lugs, Power fusing over 48 amps included, A disconnecting magnetic control contactor per stage or each 48-amp circuit within a stage, Automatic high-limit switch for primary

over-temperature protection, Manual reset high-limit switch for secondary over-temperature protection, The wire rack element suspension system allows for a low pressure drop across the coils, In horizontal applications, airflow can travel in either direction without any modification, allowing for easy field modifications, Control box features hinge and latch for easy access.

Approvals: cULus, ETL, UL International

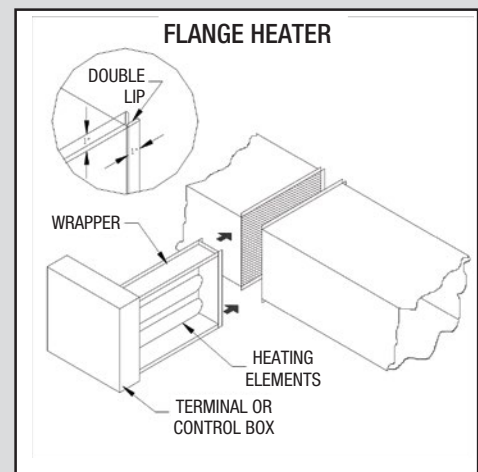
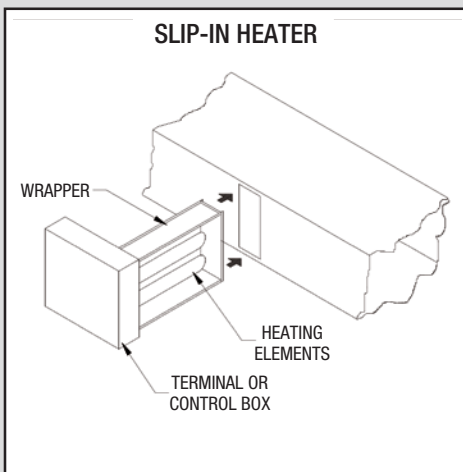

Electric Duct Heater DHC/DC Series

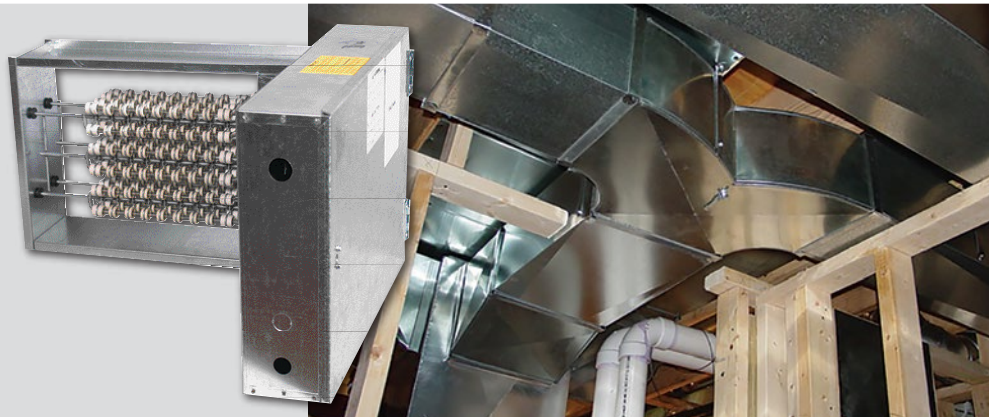

- Fan interlock
- Power terminal board
- Control terminal board
- Ground lugs
- Automatic limit switch for primary over temperature protection
- Manual reset limit switch for secondary over temperature protection
- Left hand offset control box
- Slip In or Flange mounted
- Recessed control box
- Right hand offset control box
- 80/20 (Ni/Cr) resistance wire
- Stainless steel terminals
- Vapor barrier
- Gasketed cover

The DHC/DC Heater Series

DHC/DC, products, brings innovation and flexibility custom duct heaters featuring much larger sizes (up to 10' wide x 12' high) and many accessory options. Duct heaters are used in forced air applications to provide standalone space heat or to supplement existing heating systems. Designed for zero clearance. Typical applications include; space heating, primary heating, secondary, heating, auxiliary heating, reheating, multizone and air variable volume heating.

Engineering Specifications

Composition and Materials: All sheet metal housing. 0.034+/.008/- .00 minimum spangle galvanized sheet steel grade G-90.

Accessory Options: Standard supply & control voltages, single or three phase heaters, Slip In or Flange mounted, Recessed control box, 80/20 (Ni/Cr) resistance wire, Stainless steel terminals, vapor barrier, gasketed cover

Standard Features: Open-coil element, airflow switch, detailed wiring diagram, Control terminal board and Grounding lugs, Power fusing over 48 amps included, A disconnecting magnetic control contactor per stage or

each 48-amp circuit within a stage, Automatic high-limit switch for primary over-temperature protection, Manual reset high-limit switch for secondary over-temperature protection, The wire rack element suspension system allows for a low pressure drop across the coils,

In horizontal applications, airflow can travel in either direction without any modification, allowing for easy field modifications, Control box features hinge and latch for easy access.

Approvals: cULus, ETL, UL International

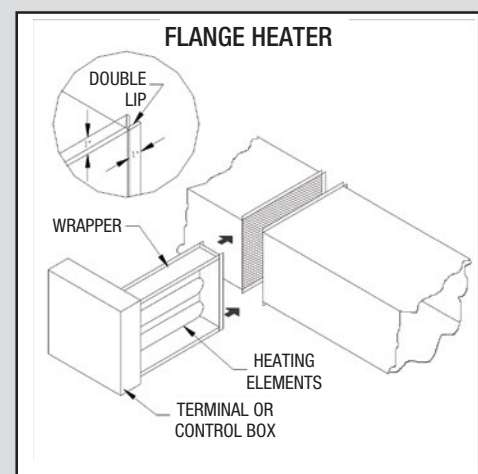
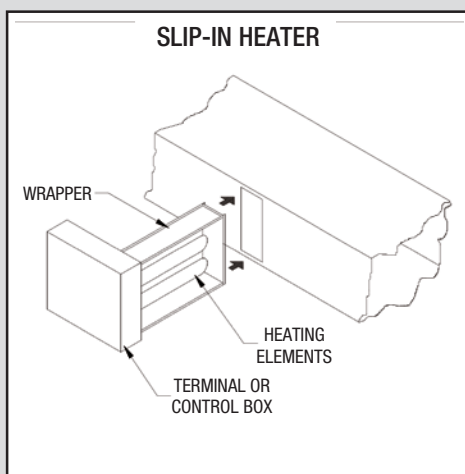

Electric Duct Heaters DHC/DC/E/R Series

TECHNICAL DATA

DETERMINING MAXIMUM HEATER KW

Duct Width (inches) x Duct Height (inches)

Total Square Inches x 156

Maximum Watts per Square Inch of Duct Face Area

Duct Width (feet) x Duct Height (feet)

Total Square Feet x 22.464

Maximum KW per Square Foot of Duct Face Area

PRESSURE DROP THROUGH HEATER

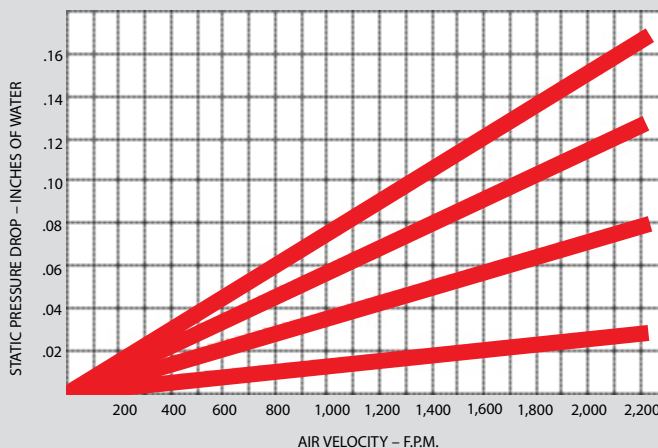

1, 2, 3 and 4 – the number of rows of heater coils
When the number of rows of heater coils is unknown, assume 4

MINIMUM AIR VELOCITIES

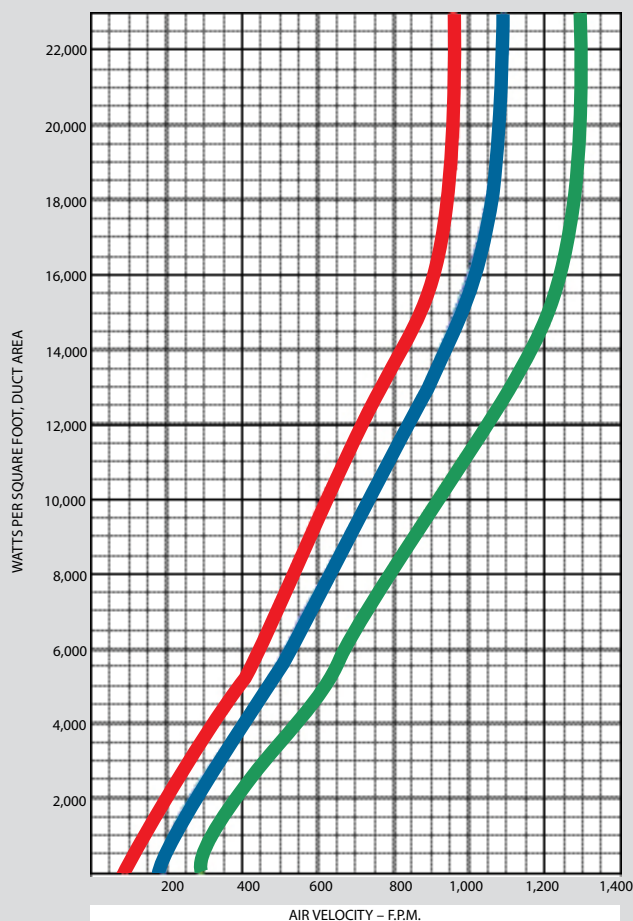

— BELOW 78°F INLET AIR
— 78°F INLET AIR TO 90°F INLET AIR
— 91°F INLET AIR TO 110°F INLET AIR

General

- A. The minimum airflow in a duct heater is directly related to the inlet air temperature. Consideration must be given to both airflow across the heater and the inlet temperature.
- B. To calculate the watts per sq. ft. of duct area, divide the total watts required by the duct area.

Example

- C. Duct size equals 2 ft. x 3 ft., total watts equal 20,000 watts per square foot equals

$$\frac{20,000}{6} = 3333$$

- D. If the air handling equipment is expressed in F.P.M., then a direct cross reference can be made by comparing the temperature of the air (as it enters the duct heater) to the KW rating on the table at the rated air velocity.

1. Draw a line horizontally from the watts/sq. ft. required to the inlet air temperature being used.
2. From this point of intersection on the inlet temperature line, draw a line down vertically to establish the air velocity.
3. In cases where the velocity is less than that determined from the chart, then either the velocity must be increased, the KW required must be reduced or both must be done.

- E. In cases where the airflow is expressed in C.F.M., convert to F.P.M. by dividing the C.F.M. by the duct area.

$$\frac{\text{C.F.M.}}{\text{Duct Area}} = \text{F.P.M.}$$

Hydronic Heaters

HYDRONIC

Heat only the rooms which need it, borrowing heat from any hot water source.

- ✓ Compatible with typical hot water sources
- ✓ Reduce utility bills with individual room control
- ✓ Built with high quality components
- ✓ Quiet operation
- ✓ More free space: no furnace room needed
- ✓ Approved for use with potable water (HWPT required)

How does King's hydronic system work?

The concept is simple: Redirect existing hot water rather than expend energy to create a new heat source. King's hydronic heating system uses hot water from your hot water tank (any hot water source — gas, electric, solar, etc.), passes it through highly efficient radiant heat plates, and returns the hot water to your tank. Inside the heater, a gentle fan draws room-temperature air across the radiant plates where the air is warmed before being pushed back out into the room. But the real magic is in our thermostat system, which maintains consistent individual room temperatures while using the smallest amount of energy possible.

Why King's hydronic system makes sense today:

- Utilizes a hot water system already in place
- Minimal floor space used — no furnace footprint
- Single room temperature control lowers cost
- Less temperature fluctuation than typical systems
- Easier to install than forced air ducting
- One less sub on job
- Minimal components to install, uses flexible hot-water lines
- Maximized energy savings with ECM fan and two-step thermostat
- Near-silent operation, smooth, consistent, comfortable room heat
- High-quality, American-made construction means low maintenance
- Works with typical hot water energy source: gas, electric, solar, etc.

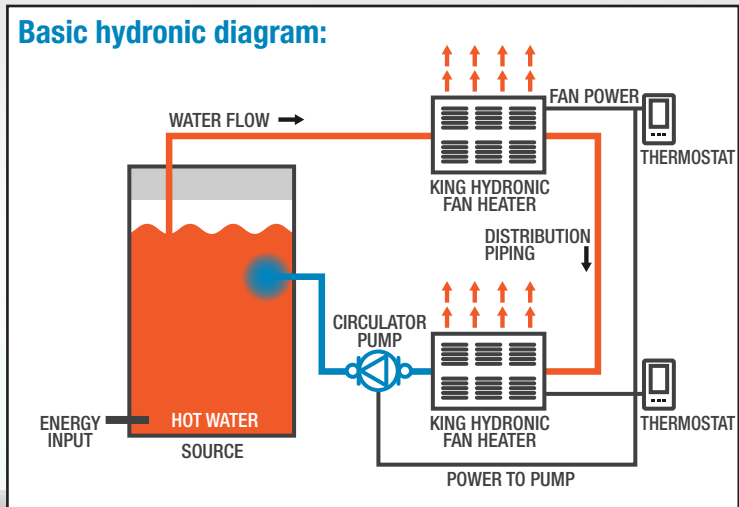

King's hydronic system offers cost-saving zone control, heat source sharing, near silent operation, quality construction, and easy installation.



Hydronic Draft Barrier HLB Series



Model Code:

HLB	F	2
A	B	C
A: Series		
B: F- Front intake		
T- Bottom intake		
C: Length		



- Bottom intake, top discharge HLBT
- Front intake, top discharge HLBF
- 12GA extruded aluminum front & back
- Snap fit 2 piece construction
- Painted and anodized finishes
- Valve compartments are 6" or 12"
- 3/4" and 1" copper tubes available
- 400 to 1000 BTUH ratings (per foot)
- Multiple sections on one common back
- 1/4" pencil proof discharge grill
- Aluminum fins for quick heat
- LB is 5"W x 7"H
- 1-year limited warranty

The HLB Series Hot Water Draft Barrier

MODEL HLB residential/commercial hydronic baseboards offers superior performance, beauty and versatility that is combined with strength and durability. Softline baseboard provides a gentle curtain of warmth along cold outside walls. No drafts and no cold spots. It is ideal for residential, apartment and commercial applications. Painting after installation does not affect the operation. The heavy gauge back plate design assures perfect alignment of the enclosure, and holds the front panel firmly in place. The unique patented heating element for models HLB are available in 3/4" and 1/2" copper tube sizes. HLB baseboard is available completely factory assembled, in coded cartons, in lengths of 2 through 10 feet. Model HLB is available in seven standard colors. Anodized finishes are also available.

Dimensional Data

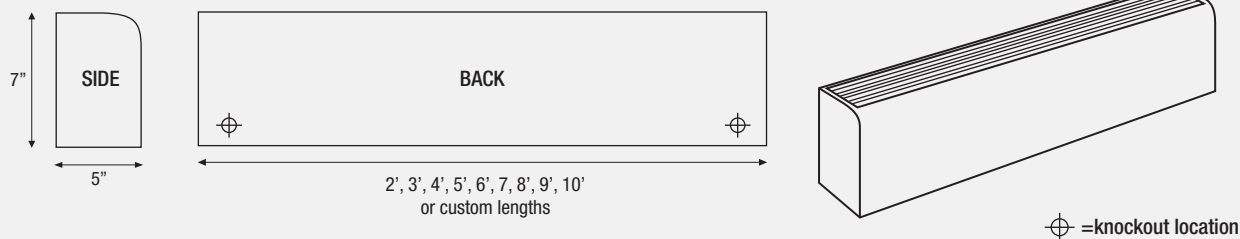

Smooth back available when pedestal mounted and back can be seen.

Engineering Specifications

Design draft barriers shall be 7" high and 5" wide. The front cover shall be one piece 12 gauge aluminum construction suitable for architectural, commercial and industrial use, with 1/4" pencil proof top discharge. The one piece cover shall be extruded aluminum for maximum strength and shall be available in lengths to 12". The front cover shall snap fit to the 12 gauge back cover with no screw heads or assembly fasteners. The 12 gauge back cover shall be suitable for mullion to mullion mounting. Standard painted finishes shall be provided.

Element: Heat sections from 2' to 10' are available. Furnish and install model emb or slit type heating element. The element shall be manufactured with 1/2", 3/4" and 1" nominal copper tubing with .010" thick aluminum fins, having full collars for uniform spacing and optimum thermal contact. Fins shall be mechanically bonded to the copper tube. One end of each element shall be expanded to accept the unexpanded end of another tube without coupling.

Element mount bracket: Element bracket is constructed of 16 gauge galvanized steel and are mounted to the backplate for noiseless expansion of element. Designed for easy installation into pre-punched mounting holes. Elements are supplied with nylon brackets for noiseless expansion.

Installation features: Model HLB construction allows simple, snap-fit installation. The back plate which houses the heating element assembly is simply attached to the wall surface at the desired height and the front cover enclosure is then snapped into place.

Pedestal features: Model HLBT-PD, HLBPF-PD, HSBST-PD shall have 2" adjustable pedestals and the heater back will be painted to match the front cover. 1" of adjustment is available on the cast iron pedestal.

Pedestal quantities: 2 on 1', 2', 3', 4', 5', 6' / 3 on 7', 8', 9', 10'

Hydronic Draft Barrier HLB Series

Side View

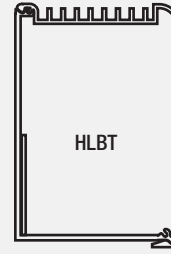
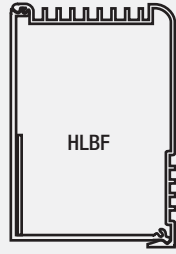

Ordering Information

FRONT INTAKE		BOTTOM INTAKE		LENGTH
MODEL	UPC	MODEL	UPC	
HLBF-2	32516	HLBT-2	32551	2'
HLBF-3	32517	HLBT-3	32552	3'
HLBF-4	32518	HLBT-4	32553	4'
HLBF-5	32519	HLBT-5	32554	5'
HLBF-6	32520	HLBT-6	32555	6'
HLBF-7	32521	HLBT-7	32556	7'
HLBF-8	32522	HLBT-8	32557	8'
HLBF-9	32523	HLBT-9	32558	9'
HLBF-10	32524	HLBT-10	32559	10'

Louvers on blank sections not punched unless otherwise spec.

Add suffix -pd to catalog number for pedestal style heater. Pedestals can be field mounted.

All valve compartments are 6" or 12" long. Price is the same for 6" or 12". Dimensions shown on inside and outside corners are wall dimensions.

Anodize finishes available, consult factory. Finished backs are available.

Units are furnished with factory installed element support.

Accessories

FRONT INTAKE		BOTTOM INTAKE		DESCRIPTION	LENGTH
MODEL	UPC	MODEL	UPC		
HLBF-IC	32525	HLBT-IC	32560	INSIDE CORNER	6"
HLBF-OC	32526	HLBT-OC	32561	OUTSIDE CORNER	6"
HLBF-SP	32528	HLBT-SP	32563	SPLICE PLATE	2"
HLBF-WT	32529	HLBF-WT	32564	WALL TRIM	4"
HLBF-VC	32530	HLBT-VC	32565	VALVE COMPANMENT	12"
HLBF-EC	32527	HLBT-EC	32562	END CAP (SPECIFY RT OR LT)	
HLB-MESH	32531			1/4" WIREMESH UNDER DISCHARGE GRILL	
HSB-PD	32515			PEDESTALS	

Elements (Sold Separately)

MODEL	UPC	DESCRIPTION	LENGTH
HSLT-3/4"	32534	3/4" COPPER TUBE FINNED ELEMENT	2'-10'
HSLT-1"	32535	1" COPPER TUBE FINNED ELEMENT	7'-10'

Corners, Fillers, Blank Sections & End Caps

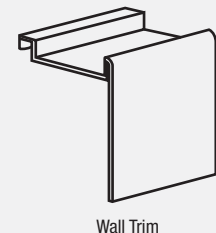
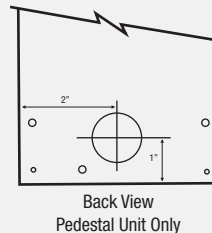
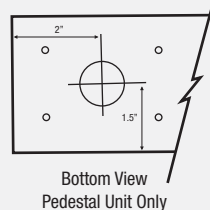
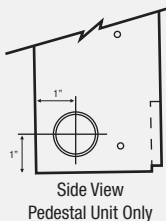
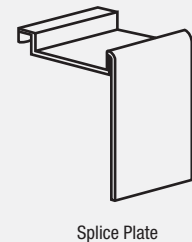
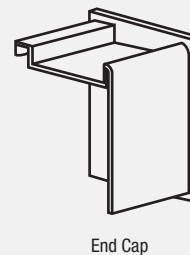
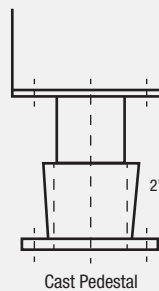
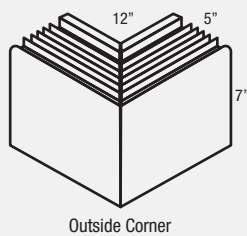
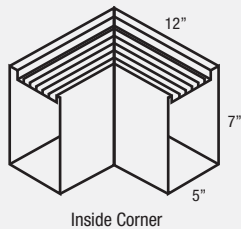

Hydronic Draft Barrier HSB Series



Model Code:

HSB	F	2
A	B	C
A: Series		
B: F- Front intake		
T- Bottom intake		
ST- Slope top, bottom intake		
C: Length		



- Bottom intake, top discharge HSBT
- Front intake, top discharge HSBF
- Slope top, bottom intake HSBST (12GA)
- 14GA extruded aluminum front & back
- Snap fit 2 piece construction
- Valve compartments are 6" or 12"
- 3/4" and 1" copper tubes available
- 400 to 1000 BTUH ratings (per foot)
- HSB is 3"W x 5"H, HSBST is 3"W x 6"H
- 1/4" pencil proof discharge grill
- Multiple sections on one common back
- 1-year limited warranty

The HSB Series Hot Water Draft Barrier

MODEL HSB residential/commercial hydronic baseboards offers superior performance, beauty and versatility that is combined with strength and durability. Softline baseboard provides a gentle curtain of warmth along cold outside walls. No drafts and no cold spots. It is ideal for residential, apartment and commercial applications. Painting after installation does not affect the operation. The heavy gauge back plate design assures perfect alignment of the enclosure, and holds the front panel firmly in place. The unique patented heating element for models HSB are available in 3/4" and 1/2" copper tube sizes. HSB baseboard is available completely factory assembled, in coded cartons, in lengths of 2 through 10 feet. Model HSB is available in seven standard colors. Anodized finishes are also available.

Dimensional Data

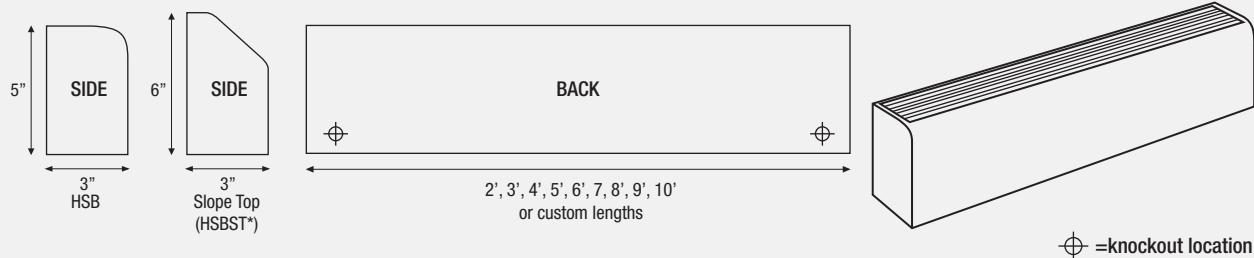

Smooth back available when pedestal mounted and back can be seen.

*Approved for residential use

Engineering Specifications

HSB Draft Barriers shall be 5" or 6" high and 3" wide. The front cover shall be 14 gauge (12GA, HSBST) aluminum construction suitable for architectural, commercial and industrial use with 1/4" pencil proof top and discharge. The one piece cover shall be extruded aluminum for maximum strength and shall be available in lengths to 14". The front cover shall snap fit to the back cover with no screw heads or assembly fasteners. The back cover shall be suitable for mullion to mullion mounting. Standard painted finishes shall be provided.

Element: Heat sections from 2' to 10' are available. Furnish and install model HEMB or HSLT type heating element. The element shall be manufactured with 3/4" and 1" nominal copper tubing with .010" thick aluminum fins, having full collars for uniform spacing and optimum thermal contact. Fins shall be mechanically bonded to the copper tube. One end of each element shall be expanded to accept the unexpanded end of another tube without coupling.

Element mount bracket: Element bracket is constructed of 16 gauge galvanized steel and are mounted to the backplate for noiseless expansion of element. Designed for easy installation into pre-punched mounting holes. Elements are supplied with nylon brackets for noiseless expansion.

Installation features: Model HSB construction allows simple, snap-fit installation. The back plate which houses the heating element assembly is simply attached to the wall surface at the desired height and the front cover enclosure is then snapped into place.

Pedestal features: Model HSBT-PD, HSBF-PD, HSBST-PD shall have 2" adjustable pedestals and the heater back will be painted to match the front cover. 1" of adjustment is available on the cast iron pedestal.

Pedestal quantities: 2 on 1', 2', 3', 4', 5', 6' / 3 on 7', 8', 9', 10'

Hydronic Draft Barrier HSB Series

Side View

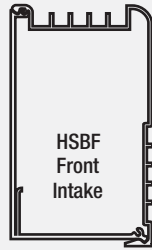

HSBF
Front
Intake

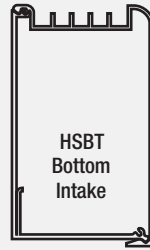

HSBT
Bottom
Intake



HSBST
Slope
Top

Ordering Information

FRONT INTAKE		BOTTOM INTAKE		SLOPE TOP		LENGTH
MODEL	UPC	MODEL	UPC	MODEL	UPC	
HSBF-2	32499	HSBT-2	32536	HSBST-2	32566	2'
HSBF-3	32500	HSBT-3	32537	HSBST-3	32567	3'
HSBF-4	32501	HSBT-4	32538	HSBST-4	32568	4'
HSBF-5	32502	HSBT-5	32539	HSBST-5	32569	5'
HSBF-6	32503	HSBT-6	32540	HSBST-6	32570	6'
HSBF-7	32504	HSBT-7	32541	HSBST-7	32571	7'
HSBF-8	32505	HSBT-8	32542	HSBST-8	32572	8'
HSBF-9	32506	HSBT-9	32543	HSBST-9	32573	9'
HSBF-10	32507	HSBT-10	32544	HSBST-10	32574	10'

Louvers on blank sections not punched unless otherwise spec.

Add suffix -pd to catalog number for pedestal style heater. Pedestals can be field mounted.

All valve compartments are 6" or 12" long. Price is the same for 6" or 12". Dimensions shown on inside and outside corners are wall dimensions.

Anodize finishes available, consult factory. Finished backs are available.

Units are furnished with factory installed element support.

Accessories

FRONT INTAKE		BOTTOM INTAKE		DESCRIPTION	LENGTH
MODEL	UPC	MODEL	UPC		
HSBF-IC	32508	HSBT-IC	32545	INSIDE CORNER	6"
HSBF-OC	32509	HSBT-OC	32546	OUTSIDE CORNER	6"
HSBF-SP	32511	HSBT-SP	32548	SPLICE PLATE	2"
HSBF-WT	32512	HSBT-WT	32549	WALL TRIM	4"
HSBF-VC	32513	HSBT-VC	32550	VALVE COMPARTMENT	12"
HSBF-EC	32510	HSBT-EC	32547	END CAP (SPECIFY RT OR LT)	
HSB-MESH	32514			1/4" WIREMESH UNDER DISCHARGE GRILL	
HSB-PD	32515			PEDESTALS	

Elements (Sold Separately)

MODEL	UPC	DESCRIPTION	LENGTH
HSLT-3/4"	32534	3/4" COPPER TUBE FINNED ELEMENT	2'-10'
HSLT-1"	32535	1" COPPER TUBE FINNED ELEMENT	7'-10'

Corners, Fillers, Blank Sections & End Caps

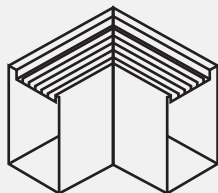

Inside Corner

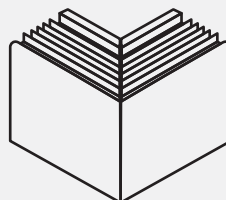

Outside Corner

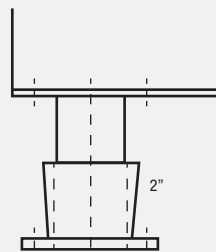

Cast Pedestal

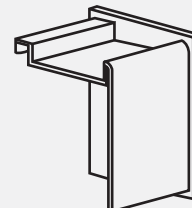

End Cap

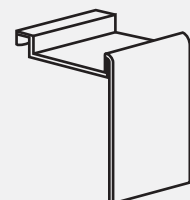

Splice Plate

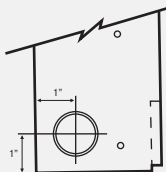

Side View
Pedestal Unit Only

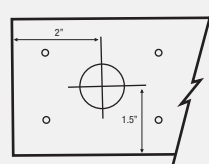

Bottom View
Pedestal Unit Only

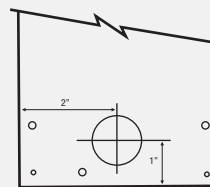

Back View
Pedestal Unit Only

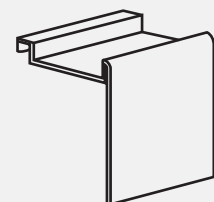

Wall Trim

Small Hydronic Heater H-Series



Model Code:

H	6	12	6/8	AS-FS	GW
A	B	C	D	E	F

A: H Series Hot Water
 B: Number of copper tubes in coil
 C: Voltage 12 = 120 Volt
 D: 6,000 Btu heat output @ 140°F
 8,000 Btu heat output @ 160°F
 E: Aqua Stat / Fan Switch
 F: Grill color



- Tangential Blowers
- Fast Coil Heating
- Quiet Operation
- 1/2" Trade size copper tubes
- Flow-through design
- 4 or 8 Aluminum fins per inch
- Easy motor removal for maintenance
- Permanently lubricated motor
- Powder-coated white grill
- Hi / Off / Lo fan switch
- Use HW series thermostats
- 2-year limited warranty

The H-Series Small Hydronic Heater - 1,800 to 10,500 BTU

King's H Series small hydronic heater uses the energy from a building's hot water source to offer efficient, whisper quiet operation and the ability to reduce utility bills with individual thermostat room control. By installing hydronic systems in every room, you can easily heat only the areas in use and conserve energy. Designed to fit neatly between standard wall studs, this in-wall heater provides out of the way positioning ideal for use in bedrooms, bathrooms, and laundry rooms. Provides 1800 to 10,500 Btu heat output.

Model Number	Volts	Can Size	Grill Size
H412 – all versions	120	9½"h x 14¾"w x 4¾"d	10½"h x 15¾"w x 7/8"d
H612 – all versions	120	11"h x 14¾"w x 4¾"d	12½"h x 15¾"w x 7/8"d

Ordering Information

MODEL	FINS PER INCH	FT. OF WATER PRESSURE DROP @ 2 GPM	Btu@2GPM	120°F 48°C	140°F* 60°C	160°F* 71°C	180°F 82°C	200°F 93°C MAX.	AMPS	RPM	CFM
H412 2/3	4	.36	High Speed	1,800	2,500	3,600	3,500	4,100	.54	2000	80
H412 2/3	4	.36	Low Speed	1,200	1,400	1,700	2,000	2,300	.51	1750	50
H412 3/4	8	.36	High Speed	2,200	3,100	4,000	4,800	6,100	.54	2000	80
H412 3/4	8	.36	Low Speed	1,200	1,800	2,400	3,000	3,800	.51	1750	50
H612 4/5	4	.54	High Speed	3,600	4,700	5,800	7,100	8,500	.48	2550	120
H612 4/5	4	.54	Low Speed	3,200	4,000	5,000	6,100	7,300	.40	1850	105
H612 6/8	8	.54	High Speed	4,100	6,000	7,600	9,100	10,500	.48	2500	120
H612 6/8	8	.54	Low Speed	3,700	5,200	6,500	7,900	9,600	.40	1850	105

*most common water temperature range

Coils are made of copper alloy 122 manufactured to ATSM B-75 specifications. Brazing alloy is AWS-BCUP2 for use with potable water systems.

Electrical circuit size: 15 amp maximum.

BTU ratings based on 68° entering air. To calculate 1 GPM, multiply by 0.95. To calculate 4 GPM, multiply by 1.05.

Engineering Specifications

Contractor shall supply and install H Series hydronic fan heaters manufactured by King Electrical Mfg. Co., Seattle, Washington.

Motor: 2 speed shaded pole impedance protected. Permanently lubricated. Bronze bearings.

Blower: Tangential blower to provide 50 or 120 CFM of air. Quiet operation of less than 53 dB A weighted scale at high speed. Easily removed for service. Bronze, not plastic, bearings.

Coils: 1/2" ID Copper tubes with Aluminum fins of no more than 8 fins per inch for free flow of air and maximum circulation of air and water. Tested at 300 PSI for leaks. Copper tube used in coil is Alloy 122 made to ASTM B-75 specifications. For potable water use.

Grill: 20 gauge mild Steel, louvered with Nickel-plated grill screws. Powder-coated in white.

Wall Can: 20 gauge mild Steel, electro-galvanized to resist corrosion. 1/2" knockout in bottom of can and QuickSet™ bend out mounting tabs for fast installation.

Fan Switch: 3 position fan switch High / Off / Low. Rated at 10 Amps with wire leads and insulated ¼" quick connects.

Terminal Board: All electrical connections will terminate at a phenolic terminal board with ¼" male brass blades for easy wiring.

Water Connections: 1/2" ID bare Copper tubes de-burred. Tested at 300 PSI for leaks. Clean out tubes for water connection.

Approvals: ETL (3131491PRT-001). All King heaters are tested to UL 1995 Standards. Approved for USA and Canada. CSA/C22.2.

Hydronic Kickspace Heater HT Series



Model Code:

HT	4	12	2/3	AS	GW
A	B	C	D	E	F

A: Series
B: Number of Copper Tubes in Coil
C: 12 - 120V
D: BTU Heat Output
E: Aqua Stat
F: Grille White, Almond or Black color



- Tangential Blowers
- Fast Coil Heating
- Quiet Operation
- 1/2" Trade size copper tubes
- Flow-through design
- 4 or 8 Aluminum fins per inch
- Easy motor removal for maintenance
- Permanently lubricated motor
- Powder-coated white grill
- Hi / Off / Lo fan switch
- Use HW series thermostats
- 1 Year Warranty

The HT Series Hydronic Kickspace Heater

King's HT Series Kicks-pace hydronic heater uses the energy from a building's existing hot water source to offer efficient, whisper quiet operation and the ability to reduce utility bills with individual room control. By installing hydronic heaters in every room, you can easily heat only the areas in use and conserve energy. Uniquely designed to add heat to areas of the home previously thought not possible. With a compact, space-saving design the HT heater can be inconspicuously installed in the kick-space area at the base of kitchen and bathroom cabinets, under window sills or even in stair risers, providing warmth and comfort to formerly troublesome areas. Provides 1700 to 9950 BTU heat output.

Ordering Information

MODEL	FINS PER INCH	FT. OF WATER PRESSURE DROP @ 2 GPM	AMPS	RPM	CFM	BTUH@2GPM	120°	140**	160**	180°	200° MAX.
HT412 2/3	8	0.36	0.54	2000	83	High Speed	1,700	2,500	3,400	4,600	5,200
HT412 2/3	8	0.36	0.51	1800	76	Low Speed	1,600	2,400	3,200	4,000	5,000
HT612 4/5	8	0.54	0.54	2000	83	High Speed	2,800	4,000	5,100	6,900	8,200
HT612 4/5	8	0.54	0.51	1800	76	Low Speed	2,400	3,250	4,350	6,000	6,500
HT812 5/7	8	0.72	0.54	2000	83	High Speed	3,675	5,000	6,600	7,500	9,950
HT812 5/7	8	0.72	0.51	1800	76	Low Speed	3,200	4,300	5,400	7,000	8,400

*Aqua Stat not required when using a King HW series hydronic thermostat with fan start-up delay. In-built Aqua Stat (AS) is available, consult factory for price and availability. Coils are made of copper alloy 122 manufactured to ATSM B-75 specifications. Brazing alloy is AWS-BCUP2 for use with potable water systems. Electrical circuit size: 15 amp maximum. BTU ratings based on 68° entering air. To calculate 1 GPM, multiply by 0.95. To calculate 4 GPM, multiply by 1.05. Grille colors available in White (-GW) or Black (-GB) or Almond (-GA). Add suffix to end of model number.

MODEL	AQUA STAT	CONTROLS FAN SWITCH	WHITE	GRILLES ALMOND	BLACK	WATER TEMPERATURE 140°F/60°C	WATER TEMPERATURE 160°F/72°C	VOLTS	AMPS
HT412 2/3	AS	FS	GW	GA	GB	2500	3400	120	0.36
HT612 4/5	AS	FS	GW	GA	GB	4000	5100	120	0.36
HT812 5/7	AS	FS	GW	GA	GB	5000	6600	120	0.54

Engineering Specifications

Contractor shall supply and install H Series hydronic fan heaters manufactured by King Electrical Mfg. Co., Seattle, Washington.

Motor: 2 speed shaded pole impedance protected. Permanently lubricated. Bronze bearings.

Blower: Tangential blower to provide 83 CFM or 76 CFM of air. Quiet operation of less than 53 dB A weighted scale at high speed. Easily removed for service. Bronze, not plastic, bearings.

Coils: 1/2" trade size Copper tubes with Aluminum fins of no more than 4 fins per inch for free flow of air and maximum circulation of air and water. Tested at 300 PSI for leaks. Bleed valve to purge air. Copper tube used in coils is Alloy 122 made to ASTM B-75 specifications.

Grill: 20 gauge mild Steel, louvered with Nickel-plated grill screws. Powder-coated in white.

Wall Can: 20 gauge mild Steel, electro-galvanized to resist corrosion. 1/2" knockout in bottom of can and QuickSet™ bend out mounting tabs for fast installation.

Fan Switch: 3 position fan switch High / Off / Low. Rated at 10 Amps with wire leads and insulated 1/4" quick connects.

Terminal Board: All electrical connections will terminate at a phenolic terminal board with 1/4" male brass blades for easy wiring.

Water Connections: 5/8" bare Copper tubes de-burred. Tested at 300 PSI for leaks. Clean out tubes for water connection.

Approvals: cETLus. . All King heaters are tested to UL 1995 Standards. Approved for USA and Canada. CSA/C22.2.

Hydronic Kickspace Heater HT Series

Dimensional Data

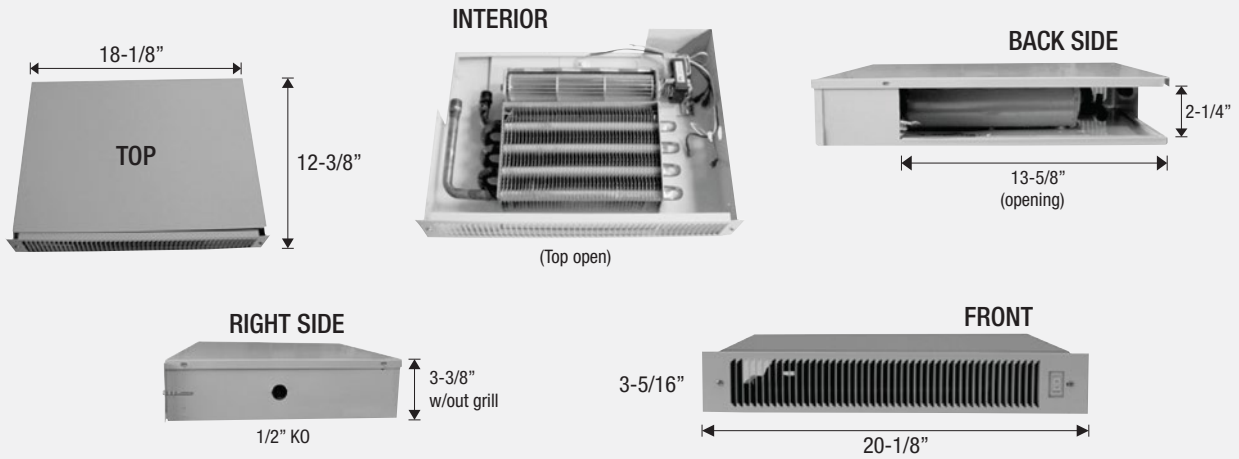

Aquastat



The optional **aqua stat** component makes sure the water temperature is over 115° before the fan is turned on.

3-Position Switch



All models include a pre-wired, clear, easy-to-read terminal board with wiring diagram.

Terminal Board

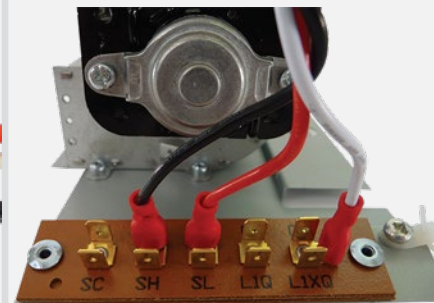

The optional fan speed switch allows fan speeds of high, low and a center "off" position.

Medium Hydronic Heater HM/HME Series



Model Code:

HM	8	12	6/9	AS-FS	GW
A:	B:	C:	D:	E:	F:

A: Series
 B: Number of Copper Tubes in Coil
 C: 12 - 120V
 D: BTU Heat Output
 E: Aqua Stat / Fan Switch
 F: Grill White or Black color



- Tangential Blowers
- Fast Coil Heating
- Quiet Operation
- 1/2" Trade size copper tubes
- Flow-through design
- 4 or 8 Aluminum fins per inch
- Easy motor removal for maintenance
- Permanently lubricated motor
- Powder-coated white grill
- Hi / Off / Lo fan switch
- Use HW series thermostats
- 2-year limited warranty

HM / HME Series Hydronic Medium Heater - 4,960 to 18,700 BTU

King's HM / MHE Series medium hydronic heater uses the energy from a building's existing hot water source to offer efficient, whisper quiet operation and the ability to reduce utility bills with individual room control. By installing hydronic heaters in every room, you can easily heat only the areas in use and conserve energy. Designed to fit neatly between standard wall studs, this in-wall heater provides out of the way positioning ideal for use in bedrooms, bathrooms, and laundry rooms. For use in both residential and commercial applications. Provides 4960 to 18,700 Btu heat output.

Model Number	Volts	Can Size				Grill Size		
HM & HME 812 & 1012 – all versions	120	21¼" h x 14 ¼" w x 4¾" d				23¼" h x 15½" w x ¾" d		

MODEL	Water Pressure Drop at 2 GPM	120°F 48°C	140°F* 60°C	160°F* 71°C	180°F 82°C 200°F MAX	Motor Hi/Lo CFM	Decibels at 3-ft distance	Hi/Lo: Amps Hi/Lo: Watts
HM812 6/9	.72	4800 Btu	6250 Btu	9500 Btu	13700 Btu	3 watt output	Hi 55 dbA	.30 / .29 Amps
		3300 Btu	4900 Btu	7100 Btu	11000 Btu	250 / 150CFM	Lo 52 dbA	36 / 34.8 Watts
HM812 8/11	.72	6000 Btu	8550 Btu	11200 Btu	14800 Btu	5 watt output	Hi 62 dbA	.42 / .38 Amps
		4800 Btu	7100 Btu	8000 Btu	11000 Btu	375 / 220 CFM	Lo 58 dbA	50.4 / 45.6 Watts
HM1012 10/13	.90	7500 Btu	10000 Btu	13500 Btu	16600 Btu	3 watt output	Hi 55 dbA	.30 / .29 Amps
		5500 Btu	7900 Btu	9750 Btu	12000 Btu	250 / 150CFM	Lo 52 dbA	36 / 34.8 Watts
HM1012-11/15	.90	8812 Btu	11700 Btu	15500 Btu	18700 Btu	5 watt output	Hi 62 dbA	.42 / .38 Amps
		6600 Btu	8800 Btu	11600 Btu	14000 Btu	375 / 220 CFM	Lo 58 dbA	50.4 / 45.6 Watts

Energy saver ECM Motor	Water Pressure Drop at 2 GPM	120°F 48°C	140°F* 60°C	160°F* 71°C	180°F 82°C	Progressive CFM	RUN / START	Energy Saver Hi/Lo: Amps Hi/Lo: Watts
HME 812-8/11	.72	6000 Btu	8550 Btu	11200 Btu	14800 Btu	150 to 375 High	Hi 57 / 54 dbA	.06 / .04 Amps
		4800 Btu	7100 Btu	8000 Btu	11000 Btu	150 to 250 Low	Lo 54 / 51 dbA	7.2 / 4.8 Watts
HME1012-11/15	.90	8812 Btu	11700 Btu	15500 Btu	18700 Btu	150 to 375 High	Hi 63 / 60 dbA	.09 / .06 Amps
		6600 Btu	8800 Btu	11600 Btu	14000 Btu	150 to 250 Low	Lo 54 / 51 dbA	10.8 / 7.2 Watts

*most common water temperature range. Coils are made of copper alloy 122 manufactured to ATSM B-75 specifications. Brazing alloy is AWS-BCUP2 for use with potable water systems. Electrical circuit size: 15 amp maximum. BTU ratings based on 68° entering air. To calculate 1 GPM, multiply by 0.95. To calculate 4 GPM, multiply by 1.05.

Engineering Specifications

Contractor shall supply and install HM/HME Series hydronic fan heaters manufactured by King Electrical Mfg. Co., Seattle, Washington.

Motor: 2 speed shaded pole impedance protected. Permanently lubricated. Bronze bearings.

Blower: Tangential blower to provide 150-375 CFM of air. Quiet operation of less than 53 dB A weighted scale at high speed. Easily removed for service. Bronze, not plastic, bearings.

Coils: 1/2" OD Copper tubes with Aluminum fins of no more than 4 fins per inch for free flow of air and maximum circulation of air and water. Tested at 300 PSI for leaks. Bleed valve to purge air. Copper tube used in coils is Alloy 122 made to ASTM B-75 specifications.

Grill: 20 gauge mild Steel, louvered with Nickel-plated grille screws. Powder-coated in white.

Wall Can: 20 gauge mild Steel, electro-galvanized to resist corrosion. 1/2" knockout in bottom of can and QuickSet™ bend out mounting tabs for fast installation.

Fan Switch: 3 position fan switch High / Off / Low. Rated at 10 Amps with wire leads and insulated ¼" quick connects.

Terminal Board: All electrical connections will terminate at a phenolic terminal board with ¼" male brass blades for easy wiring.

Water Connections: 1/2" bare Copper tubes de-burred. Tested at 300 PSI for leaks. Clean out tubes for water connection.

Approvals: ETL (3131491PRT-001). All King heaters are tested to UL 1995 Standards. Approved for USA and Canada. CSA/C22.2.

Large Hydronic Heater HL/HLE Series

Model Code:

HL	10	12	8/11	AS-FS	GW
A	B	C	D	E	F

A: Series
B: Number of Copper Tubes in Coil
C: 12 - 120V
D: BTU Heat Output
E: Aqua Stat / Fan Switch
F: Grill White or Black color



- Tangential Blowers
- 1/2" Trade size copper tubes
- Easy motor removal for maintenance
- Hi / Off / Lo fan switch
- Fast Coil Heating
- Flow-through design
- Permanently lubricated motor
- Use HW series thermostats
- Quiet Operation
- 4 or 8 Aluminum fins per inch
- Powder-coated white grill
- 2-year limited warranty

HL / HLE Series Large Hydronic Heater - 6,700 to 27,250 BTU

King's HL HLE Series large hydronic heater uses the energy from a building's existing hot water source to offer efficient, whisper quiet operation and the ability to reduce utility bills with individual room control. By installing hydronic heaters in every room, you can easily heat only the areas in use and conserve energy. Designed to fit neatly between standard wall studs, this in-wall heater provides out of the way positioning ideal for use in public areas, corridors, entry ways and large rooms or hallways. For use in both residential and commercial applications. Provides 6700 to 27,250 BTU heat output. Recommended 17 BTU per square foot for new construction.

Model Number	Volts	Can Size	Grill Size
HL & HLE 1012 & 1412 – all versions	120	24¾" h x 14 ¼" w x 4¾" d	26¼" h x 15½" w x ¾" d

HL

MODEL	FT. OF WATER PRESSURE DROP @ 2 GPM	120°F 48°C	140°F* 60°C	160°F* 71°C	180°F 82°C 200°F MAX	Motor Hi/Lo CFM	Decibels at 3-ft distance	Hi/Lo: Amps Hi/Lo: Watts
HL1012 8/11	.90	6000 BTU 4700 BTU	8550 BTU 6200 BTU	11100 BTU 8000 BTU	14800 BTU 11000 BTU	3 watt output 250 / 150CFM	Hi 57/55 dbA Lo 54/52 dbA	.30 / .29 Amps 36 / 34.8 Watts
HL1012 10/13	.90	7500 BTU 5500 BTU	10000 BTU 8000 BTU	13500 BTU 9750 BTU	16600 BTU 12000 BTU	3 watt output 250 / 150CFM	Hi 57/55 dbA Lo 54/52 dbA	.30 / .29 Amps 36 / 34.8 Watts
HL1012-11/15	.90	8812 BTU 6600 BTU	11700 BTU 8800 BTU	15500 BTU 11600 BTU	18700 BTU 14000 BTU	5 watt output 375 / 220 CFM	Hi 64/62 dbA Lo 60/58 dbA	.42 / .38 Amps 50.4 / 45.6 Watts
HL1412-15/20	1.2	10600 BTU 7400 BTU	15500 BTU 11600 BTU	20000 BTU 15000 BTU	26000 BTU 19500 BTU	5 watt output 375 / 220 CFM	Hi 64/62 dbA Lo 60/58 dbA	.42 / .38 Amps 50.4 / 45.6 Watts
HL1412-20/25	1.2	17000 BTU 13000 BTU	20000 BTU 16800 BTU	24050 BTU 19100 BTU	27250 BTU 22500 BTU	9 watt output 375 / 220 CFM	Hi 64/62 dbA Lo 60/58 dbA	.42 / .38 Amps 50.4 / 45.6 Watts
Energy saver ECM Motor	FT. OF WATER PRESSURE DROP @ 2 GPM	120°F 48°C	140°F* 60°C	160°F* 71°C	180°F 82°C	Progressive CFM	Decibels at 3-ft distance	Energy saver Hi/Lo: Amps Hi/Lo: Watts
HLE 1012-11/15	.90	8812 BTU 6600 BTU	11700 BTU 8800 BTU	15500 BTU 11600 BTU	18700 BTU 14000 BTU	150 to 375 High 150 to 250 Low	Hi 57/55 dbA Lo 54/52 dbA	.06 / .04 Amps 7.2 / 4.8 Watts
HLE 1412-15/20	1.2	10600 BTU 8812 BTU	15500 BTU 11700 BTU	20000 BTU 15500 BTU	26000 BTU 18700 BTU	150 to 375 High 150 to 250 Low	Hi 63/61 dbA Lo 54/52 dbA	.09 / .06 Amps 10.8 / 7.2 Watts

HLE

*most common water temperature range. Coils are made of copper alloy 122 manufactured to ATSM B-75 specifications. Brazing alloy is AWS-BCUP2 for use with potable water systems. Electrical circuit size: 15 amp maximum. BTU ratings based on 68° entering air. To calculate 1 GPM, multiply by 0.95. To calculate 4 GPM, multiply by 1.05.

Engineering Specifications

Contractor shall supply and install HL/HLE Series hydronic fan heaters manufactured by King Electrical Mfg. Co., Seattle, Washington.

Motor: 2 speed shaded pole impedance protected. Permanently lubricated. Bronze bearings.

Blower: Tangential blower to provide 150 to 375 CFM of air. Quiet operation of less than 53 dBA weighted scale at high speed. Easily removed for service. Bronze, not plastic, bearings.

Coils: 1/2" ID Copper tubes with Aluminum fins of no more than 4 fins per inch for free flow of air and maximum circulation of air and water. Tested at 300 PSI for leaks. Bleed valve to purge air. Copper tube used in coils is Alloy 122 made to ASTM B-75 specifications.

Grill: 20 gauge mild Steel, louvered with Nickel-plated grille screws. Powder-coated in white.

Wall Can: 20 gauge mild Steel, electrogalvanized to resist corrosion. 1/2" knockout in bottom of can and QuickSet™ bend out mounting tabs for fast installation.

Fan Switch: 3 position fan switch High / Off / Low. Rated at 10 Amps with wire leads and insulated ¼" quick connects.

Terminal Board: All electrical connections will terminate at a phenolic terminal board with ¼" male brass blades for easy wiring.

Water Connections: 1/2" bare Copper tubes de-burred. Tested at 300 PSI for leaks. Clean out tubes for water connection.

ECM Motor: We program the motor to start at slowly and quietly at 50% of its maximum speed. Over a 3 to 5 minute period, if the room is not reaching the set point it will slowly ramp up to 100% airflow to heat the room. It not only saves energy but also makes a large output heater have a soft quiet start, yet can increase to its maximum output and sound level over time while not disturbing residents.

Approvals: ETL (3131491PRT-001). All King heaters are tested to UL 1995 Standards. Approved for USA and Canada. CSA/C22.2.

Hydronic Thermostat HW, HWP & HWPT



HW120
Non Programmable
For Hydronic Heaters



HWP120
Programmable
For Hydronic Heaters
HWPT120
Programmable
Adds Timer for Pump

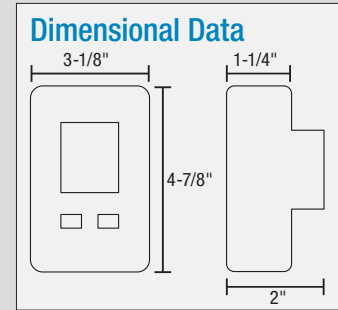

- Save up to 15% on your heating costs (HW)
- Save up to 28% on your heating costs (HWP/HWPT)
- Even temperature control
- Pre-programmed
- LCD backlight display with temperature
- Green backlight display
- Push button temp. settings
- 1 year warranty
- Electronic temperature sensing is the most accurate technology
- 3 minute cycle rate reduces temperature swings and increases comfort at all control settings
- Complies with all codes requiring anticipated or electronic thermostats
- Single pole design with third wire to power display
- Shallow design allows more wiring room inside full electrical boxes
- 2 circuits, 1 minute delay on 2nd circuit
- HWPT adds pump exerciser for potable water applications



Ordering Information

MODEL	UPC	TYPE	WIRE LEADS	VOLTS	AMPS	TEMP. RANGE
HW120	19048	Electronic Line Voltage	4 Wire	120	12.5	40°F-95°F
HWP120	19047	7 Day Independent Electronic Programmable	4 Wire	120	12.5	44°F-95°F
HWPT120	19049	7 Day Ind. Elec. Prog. w/ 15 min. pump timer every 24 hrs.	4 Wire	120	12.5	44°F-95°F

The HW Non Prog. Electronic Thermostat

The HW (hot water) Series was intended for use as a 2 circuit thermostat controlling a circuit pump and fan on a hydronic coil heating system, though it could be used when needing a 2 circuit control with 1 minute delay on the second circuit. This control solves the historic problem of using a standard 22 Amp bi-metal heating thermostat on a hydronic system which require high Amp loads to be accurate. Without a load they will not shut off properly, continuing to circulate hot water when not needed. This control positively controls both circuits creating energy savings and superior comfort control, while providing excellent hydronic control.

The HWP Programmable Electronic Thermostat

Adds 7 independent day programming with 4 times and temperature settings per day to save energy and also start system before you get home.

The HWPT Programmable Electronic Thermostat

Programmable features plus it adds a 15 minute pump exerciser every 24 hours as required by code on potable water heating systems. First cycle will start in 12 hours from the power on time so that all cycling will happen at night.

HW Technical Specifications

Temperature Range:
40°F to 95°F (4°C - 35°C)
Temperature Default:
Your saved setting
Display Format: LCD
Display Size: Large Format
Sample Rate: Every 60 seconds
Delay On or Off: 3 minutes
Heat Indicator: Radiant
Relay Rating: 12.5 Amps
Accuracy: ± .9°F @ 1500W
Maximum Amps: 12.5 res. per pole
Maximum Watts: 3000 @ 240V
2600 @ 208V - 1500 @ 120V per pole
Minimum Watts: 0
Power Source: 120VAC, 50-60Hz
• 12.5 Amps per circuit.

- Four wire installation.
- Snap action relays.
- Wire leads #16 AWG.
- ¾" depth into wire box.
- 40°F to 95°F (4°C - 35°C) set point range.
- Thermistor sensor.
- Digital thermometer/set point.
- Large LCD display.
- Meets energy code requirements.
- 1.2 degrees differential.
- 3 min. delay between cycles.
- 1 min. delay between circuits.
- For use on hydronic fan coils.
- On/Off switch for green backlight & system.
- Battery backup.

HWP/HWPT Technical Specifications

Temperature Range:
44°F to 95°F (7°C - 35°C)
Temperature Default:
Your saved setting
Display Format: LCD
Display Size: Large Format
Sample Rate: Every 60 seconds
Delay On or Off: 3 minutes
Heat Indicator: LCD "heater on"
Relay Rating: 12.5 Amps
Accuracy: ± .9°F @ 2000W
Maximum Amps: 12.5 resistive
Maximum Watts: 3000 @ 240V
2600 @ 208V - 1500 @ 120V
Minimum Watts: 0
Power Source: 120VAC, 50-60Hz
• 12.5 Amps per circuit.

- Four wire installation.
- Snap action relays.
- Wire leads #16 AWG.
- ¾" depth into wire box.
- 44°F to 95°F (7°C - 35°C) set point range.
- Thermistor sensor.
- Digital thermometer/set point.
- Large LCD display.
- Meets energy code requirements.
- 1.2 degrees differential.
- 3 min. delay between cycles.
- 1 min. delay between circuits.
- For use on hydronic fan coils.
- On/Off switch for green backlight & system.
- Battery backup.
- HWPT adds exerciser pump timer.

Electronic Hydronic Thermostat HB



2 Circuit Control of Pump & Fan for Hydronic System



Programmable



- Save up to 15% on your heating costs
- Even temperature control
- LCD heater ON indicator
- LCD display with temperature
- White color with gray print
- Tap key temperature settings
- 1 year warranty
- Electronic temperature sensing is the most accurate technology
- 3 minute cycle rate reduces temperature swings and increases comfort at all control settings
- Complies with all codes requiring anticipated or electronic thermostats
- Dual single pole design with three wires
- Shallow design allows more wiring room inside full electrical boxes
- Use on 120/208/240V
- Uses AA batteries



Ordering Information

MODEL	UPC	TYPE	PACKAGING	WIRE LEADS	VOLTS	AMPS Per Pole	TEMP. RANGE
HB	19050	Electronic Line Voltage	Box (50 pieces)	3 Wire	120/208/240	16	40°F-95°F

The HB Electronic Thermostat

This HB Series was intended to be used as a 2 circuit thermostat controlling a circulation pump and a fan on a hydronic coil heating system, though it could have other uses where you need a 2 circuit control with a 1 minute delay on the 2nd circuit. This control will solve the historic problem of using a standard 22 Amp bi-metal heating thermostat on a hydronic system which require high Amp loads to be accurate. Without a load on a Bi-metal thermostat it will not shut off circulating hot water when not needed. This HB control positively controls both circuits creating energy savings, superior control and comfortable living spaces.

Installation

This line voltage device should be installed and serviced by a qualified electrician. The thermostat has been designed to mount to a standard 2" X 4" electrical outlet box. Leveling of the thermostat is not required. Mounting screws are provided. Mount the thermostat about five feet above the floor in an area with good air circulation. Avoid mounting the thermostat where it will be affected by drafts, air from ducts, and radiant heat sources such as appliances, the sun or plumbing pipes. Typically the best location is above a light switch for that room.

Technical Specifications

Temperature Range:

40°F to 95°F (4°C - 35°C)

Temperature Default: 68°F (20°C)

Display Format: LCD

Display Size: Large Format

Sample Rate: Every 60 seconds

Delay On or Off: 3 minutes

Heat Indicator: LCD "heater on"

Relay Rating: 16 Amps

Relay: AA battery powered

Accuracy: ± .9°F @ 2000W

Maximum Amps: 16 resistive

Maximum Watts: 3840 @ 240V -
3328 @ 208V - 1920 @ 120V

Minimum Watts: 0

Power Supply: 1-240VAC / 1-30VDC

- 16 Amps at 240V, 3840 Watts.
- 16 Amps at 208V, 3328 Watts.
- 16 Amps at 120V, 1920 Watts.
- Three wire installation.
- 2 snap action relays built-in.
- Wire leads #12 AWG.
- No depth into wire box.
- Dual switch operation.
- Electronically anticipated.
- Battery operated by AA batteries
- Thermistor sensor.
- Contemporary styling.
- Digital thermometer/set point.
- LCD display.
- Meets specific energy requirements.
- 1.5 degrees maximum.
- 3 min. delay between cycles.
- For use on hydronic fan coils.

Dimensional Data

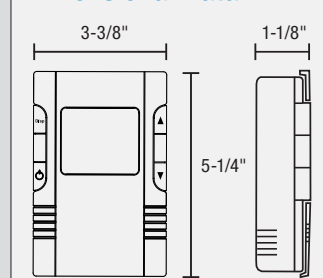

Wiring Diagram

120/208/240

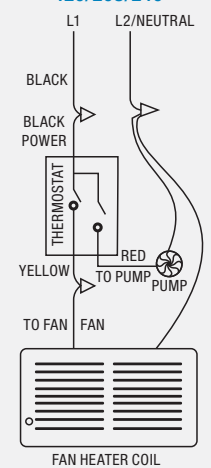

Electronic Hydronic Thermostat HBP



2 Circuit Control of Pump & Fan for Hydronic System

Non Programmable



- Save up to 28% on your heating costs
- Even temperature control
- LCD heater ON indicator
- LCD display with temperature
- White color with gray print
- 1 year warranty
- Uses AA batteries
- Electronic temperature sensing is the most accurate technology
- 3 minute cycle rate reduces temperature swings and increases comfort at all control settings
- Complies with all codes requiring anticipated or electronic thermostats
- Dual single pole design with three wires
- Shallow design allows more wiring room inside full electrical boxes
- Flame icon heat indicator, low battery indication



Ordering Information

MODEL	UPC	TYPE	PACKAGING	WIRE LEADS	VOLTS	AMPS Per Pole	TEMP. RANGE
HBP	19051	5+1+1 Day Electronic Programmable	Box (50 pieces)	3 Wire	120/208/240	16	40°F-95°F

The HBP Electronic Thermostat

This HBP Series was intended to be used as a 2 circuit thermostat controlling a circulation pump and a fan on a hydronic coil heating system, though it could have other uses where you need a 2 circuit control with a 1 minute delay on the 2nd circuit. This control will solve the historic problem of using a standard 22 Amp bi-metal heating thermostat on a hydronic system which require high Amp loads to be accurate. Without a load on a Bi-metal thermostat it will not shut off circulating hot water when not needed. This HBP control positively controls both circuits creating energy savings, superior control and comfortable living spaces.

Installation

This line voltage device should be installed and serviced by a qualified electrician. The thermostat has been designed to mount to a standard 2" X 4" electrical outlet box. Leveling of the thermostat is not required. Mounting screws are provided. Mount the thermostat about five feet above the floor in an area with good air circulation. Avoid mounting the thermostat where it will be affected by drafts, air from ducts, and radiant heat sources such as appliances, the sun or plumbing pipes. Typically the best location is above a light switch for that room.

Technical Specifications

Temperature Range:

40°F to 95°F (4°C - 35°C)

Temperature Default: 68°F (20°C)

Display Format: LCD

Display Size: Large Format

Sample Rate: Every 60 seconds

Delay On or Off: 3 minutes

Heat Indicator: LCD "heater on"

Relay Rating: 16 Amps

Relay: AA battery powered

Accuracy: ± .9°F @ 2000W

Maximum Amps: 16 resistive

Maximum Watts: 3840 @ 240V - 3328 @ 208V - 1920 @ 120V

Minimum Watts: 0

Power Supply: 1-240VAC / 1-30VDC

- 16 Amps at 240V, 3840 Watts.
- 16 Amps at 208V, 3328 Watts.
- 16 Amps at 120V, 1920 Watts.
- Three wire installation.
- Snap action relay built-in.
- Wire leads #12 AWG.
- No depth into wire box.
- 40°F to 95°F (4°C to 35°C) set point range.
- Dual switch operation.
- Electronically anticipated.
- Battery operated by AA batteries
- Thermistor sensor.
- Contemporary styling.
- Digital thermometer/set point.
- LCD display.
- Meets all energy requirements.
- 1.5 degrees maximum.
- 3 min. delay between cycles.

Dimensional Data

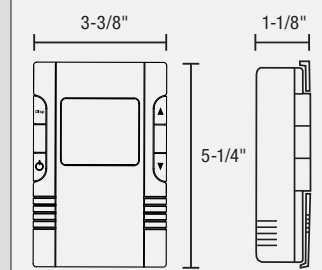

Wiring Diagram

120/208/240

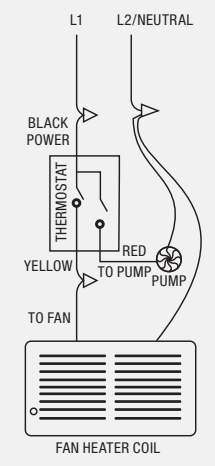

Hydronic To Electric Conversion HI Series



Model Code:

HI	4	24	22
A	B	C	D

- A: Series
- B: Length
- C: Volts (24=240)
- D: Watts



- Maintains historical building features
- Tenants can now be billed independently
- 3 aluminum ribbon heating elements
- ETL approved
- Increase comfort with zone control
- No boiler technician required
- Natural convection
- Full length limit
- Integrate with building management systems
- Simple and easy to install
- Custom sizes available
- Built in J box
- 1-year limited warranty

Boiler Conversion: Steam or Hot Water to Electric Systems

Converting your existing steam or hot water heating system is easy with the King electric heating unit! It is ETL approved for any appropriate sized steam heating cabinet – and there are countless sizes to fit your radiator cabinets! No need to remove the steam coil, just add the electric unit to the cabinet, a remote mount thermostat and tenant can now be billed for the heating and boiler can be dismantled.

There are three standard interior cabinet sizes to accommodate your retrofit!

MODEL	VOLTS	WATTS	MIN. REQ. CABINET SPACE	INSTALLED HEATER SECTION
HI2-	208/240	563/844	29" x 20" x 4¼"	18" x 14" x 3¾"
HI3-	208/240	844/1126	40" x 20" x 4¼"	31" x 14" x 3¾"
HI4-	208/240/277	1500/1687/2250	49" x 20" x 4¼"	42" x 14" x 3¾"

Without Conversion



With Conversion

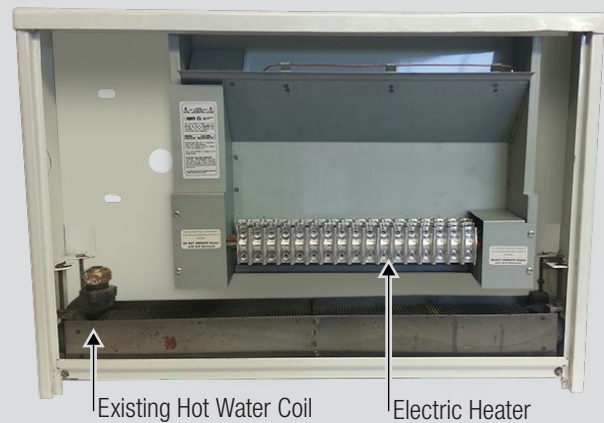

Electric Heating Cable

Electric Heating Cable

King offers a wide range of electric heating cable. Request a catalog or visit our website for a full list of products, specifications & installation.



Electric In-Floor Heat

- FC Series Electric In-Floor Cable
- FCM Series Electric In-Floor Mat
- Thermostats
- FC/FCM Accessories



Thermal Storage

- TC Series Thermal Storage Cable
- TCM Series Thermal Storage 24", 30" & 36" Mats
- Thermostats



Electric Snow Melt

- SC Series Snow Melt Cable
- SCM Series Snow Melt 208V Mat
- SCM Series Snow Melt 240V Mat



Pipe Freeze Protection

- SRP Series Self-Regulating Pre-Assembled Heating Cable
- CWP Series Constant Wattage Pipe Trace Heating Cable
- SR Series Self-Regulating Pipe Trace Heating Cable



Roof/Gutter De-Icing

- SRP Series Self-Regulating Pre-Assembled De-Icing Heating Cable
- CWR Series Constant Wattage De-Icing Heating Cable
- CWR Series IceFree Controller
- SR Series Self-Regulating De-Icing Heating Cable



Controls & Sensors

- SnowFree™ Controller Snow Melt System Kit
- PYRO Snow Melt/De-Icing System
- PYRO Pipe Trace System
- SR/SRP Accessories
- Roof/Drain De-Icing System
- Roof & Gutter De-Icing Controls
- Pipe Freeze Protection
- Snow Melt Controls

Electric In-Floor Heat



Electric In-Floor Heating Systems

King's In-Floor Heating systems provide the affordable luxury of comfort through radiant heating. Ideal for kitchens & bathrooms, in-floor heating is the easiest way to add warmth to your home. Whether using the FC Cable series or FCM Mat series, you will be completely satisfied with the results.

FCM Series Mats offer the easiest solution for in-floor heating, providing pre-fabricated mats with 3" spacing that can be rolled out quickly before final installation of the engineered wood, laminate wood, tile or stone floor. The Mat series is specifically designed for the homeowner or contractor that wants an easy and fast installation. The mat is easily cut and flipped to conform to any custom layout, refer to example below. Mats are sold separately in pre-packaged kits, which can include a thermostat, cable alarm and floor sensor.

FC Series Cable offers the flexibility to lay out and space the cable specific to an individual application. King's unique Fast-Set strapping system makes it easy to design a custom layout to maximize the coverage area. Simply install the strapping, lace the cable in a serpentine pattern as needed to work around fixtures and cabinets, making a precise in-floor heating solution. Cable is sold with strapping and in pre-packaged kits, which can include a thermostat, cable alarm and floor sensor.

FC Installation

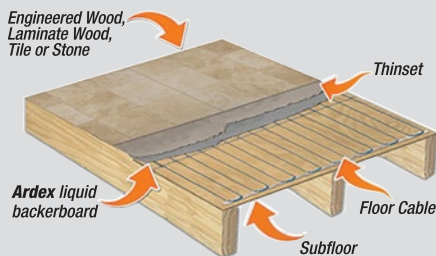

When using In-floor cable for engineered floors & laminated wood, check with your flooring manufacturer for compatibility.

Easy to Install FCM Examples

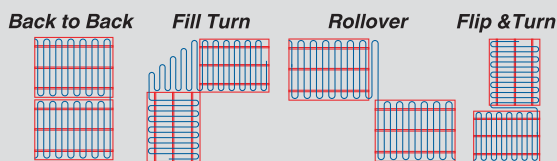

FC & FCM Cable Constructions

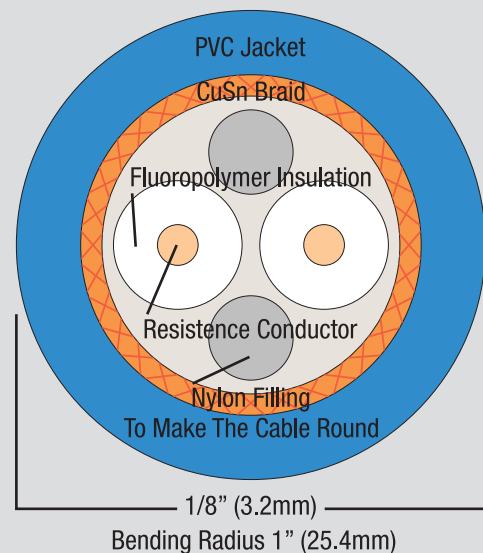

Electric In-Floor Heating Cable



Model Code:

FC 12 120 -3
A B C D

- A: Floor Cable**
- B: 12 - 120V**
24 - 240V
- C: Watts (120 to 2880)**
- D: -3 - Includes strapping**
-T - Includes thermostat
-TA - Thermostat & alarm

In-Floor Heating Cable provides comfort and well-being through radiant heating. Ideal for kitchens & bathrooms.

FC Electric In-Floor Heating Cable Features

- Provides everything needed for easy installation
- 3 Watts/Ft., available in 120V and 240V
- Innovative strapping system included
- 10 Ft. Cold Lead
- Twenty year limited warranty
- No EMF, twin conductor
- Pre-sized kits range from 5 to 320 square feet
- For use with engineered wood, laminate wood, tile, stone floors
- Professional grade quality components
- Phone & email support, online video for easy installation steps
- Tefzel® Insulation, PVC Jacket



120V

MODEL	UPC	VOLTS	STANDARD (3" SPACING)	(2" SPACING)	(4" SPACING)	WATTS	AMPS	INCLUDED STRAPPING
FC12120-3	40228	120	10 SQ. FT.	5 SQ. FT.	15 SQ. FT.	120	1.0	10 PCS
FC12180-3	40229	120	15 SQ. FT.	10 SQ. FT.	20 SQ. FT.	180	1.5	12 PCS
FC12240-3	40230	120	20 SQ. FT.	15 SQ. FT.	25 SQ. FT.	240	2.0	20 PCS
FC12300-3	40231	120	25 SQ. FT.	18 SQ. FT.	35 SQ. FT.	300	2.5	20 PCS
FC12360-3	40232	120	30 SQ. FT.	20 SQ. FT.	40 SQ. FT.	360	3.0	20 PCS
FC12480-3	40233	120	40 SQ. FT.	25 SQ. FT.	55 SQ. FT.	480	4.0	30 PCS
FC12600-3	40234	120	50 SQ. FT.	35 SQ. FT.	65 SQ. FT.	600	5.0	30 PCS
FC12720-3	40235	120	60 SQ. FT.	40 SQ. FT.	80 SQ. FT.	720	6.0	40 PCS
FC12840-3	40236	120	70 SQ. FT.	45 SQ. FT.	95 SQ. FT.	840	7.0	40 PCS
FC12960-3	40237	120	80 SQ. FT.	55 SQ. FT.	105 SQ. FT.	960	8.0	50 PCS
FC121080-3	40238	120	90 SQ. FT.	60 SQ. FT.	120 SQ. FT.	1080	9.0	50 PCS
FC121200-3	40239	120	100 SQ. FT.	65 SQ. FT.	135 SQ. FT.	1200	10.0	60 PCS

240V

MODEL	UPC	VOLTS	STANDARD (3" SPACING)	(2" SPACING)	(4" SPACING)	WATTS	AMPS	INCLUDED STRAPPING
FC24240-3	40240	240	20 SQ. FT.	15 SQ. FT.	25 SQ. FT.	240	1.0	20 PCS
FC24360-3	40241	240	30 SQ. FT.	20 SQ. FT.	40 SQ. FT.	360	1.5	20 PCS
FC24480-3	40242	240	40 SQ. FT.	25 SQ. FT.	55 SQ. FT.	480	2.0	30 PCS
FC24600-3	40243	240	50 SQ. FT.	35 SQ. FT.	65 SQ. FT.	600	2.5	30 PCS
FC24720-3	40244	240	60 SQ. FT.	40 SQ. FT.	80 SQ. FT.	720	3.0	40 PCS
FC24840-3	40245	240	70 SQ. FT.	45 SQ. FT.	95 SQ. FT.	840	3.5	40 PCS
FC24960-3	40246	240	80 SQ. FT.	55 SQ. FT.	105 SQ. FT.	960	4.0	50 PCS
FC241080-3	40247	240	90 SQ. FT.	60 SQ. FT.	120 SQ. FT.	1080	4.5	50 PCS
FC241200-3	40248	240	100 SQ. FT.	65 SQ. FT.	135 SQ. FT.	1200	5.0	60 PCS
FC241320-3	40249	240	110 SQ. FT.	75 SQ. FT.	145 SQ. FT.	1320	5.5	60 PCS
FC241440-3	40250	240	120 SQ. FT.	80 SQ. FT.	160 SQ. FT.	1440	6.0	60 PCS
FC241680-3	40251	240	140 SQ. FT.	95 SQ. FT.	190 SQ. FT.	1680	7.0	70 PCS
FC241920-3	40252	240	160 SQ. FT.	105 SQ. FT.	210 SQ. FT.	1920	8.0	80 PCS
FC242160-3	40253	240	180 SQ. FT.	120 SQ. FT.	240 SQ. FT.	2160	9.0	80 PCS
FC242400-3	40254	240	200 SQ. FT.	135 SQ. FT.	265 SQ. FT.	2400	10.0	90 PCS
FC242880-3	40390	240	240 SQ. FT.	160 SQ. FT.	320 SQ. FT.	2880	12.0	90 PCS

ACCESSORIES

- 3T Packaged with F902GFCI Thermostat
- 3TA Packaged with F902GFCI Thermostat and Cable Alarm

See FC/FCM Accessories page 5 for complete listing of accessories



Strapping

Cable Alarm

Floor Sensor

F902 GFCI Thermostat

Electric In-Floor Heating Mats

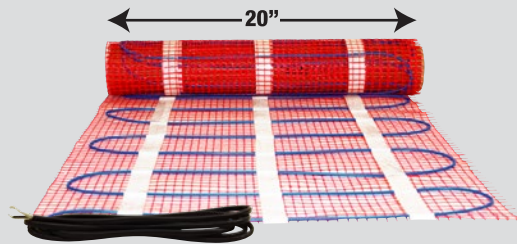

Model Code:

FCM 1 -10
A B C

A: Floor Mat

B: 12 - 120V

24 - 240V

C: Coverage Area in Sq/Ft

D: T - Includes thermostat

TA - Thermostat & alarm

In-Floor Heating Mat provides comfort and well-being through radiant heating. Ideal for kitchens & bathrooms.

FCM Electric In-Floor Heating Mat Features

- Provides everything needed for easy installation
- 12 Watts/Sq. Ft., available in 120V and 240V
- Professional grade quality components
- 10 Ft. Cold Lead
- Tefzel® Insulation, PVC Jacket
- No EMF, twin conductor
- Pre-sized kits range from 10 to 160 square feet
- For use with engineered wood, laminate wood, tile, stone floors
- Phone & email support, online video for easy installation steps
- Twenty year limited warranty
- Low memory design, cable stays flat, adhesive backing



120V

MODEL	UPC	VOLTS	MAT LENGTH	HEATED AREA (20" WIDE)	WATTS	AMPS
FCM1-10	40200	120	6.1'	10 SQ. FT.	120	1.0
FCM1-15	40201	120	9.1'	15 SQ. FT.	180	1.5
FCM1-20	40202	120	12.2'	20 SQ. FT.	240	2.0
FCM1-25	40203	120	15.2'	25 SQ. FT.	300	2.5
FCM1-30	40204	120	18.3'	30 SQ. FT.	360	3.0
FCM1-35	40205	120	21.3'	35 SQ. FT.	420	3.5
FCM1-40	40206	120	24.4'	40 SQ. FT.	480	4.0
FCM1-50	40207	120	30.5'	50 SQ. FT.	600	5.0
FCM1-60	40208	120	36.6'	60 SQ. FT.	720	6.0
FCM1-70	40209	120	42.7'	70 SQ. FT.	840	7.0
FCM1-80	40210	120	48.8'	80 SQ. FT.	960	8.0
FCM1-90	40211	120	54.9'	90 SQ. FT.	1080	9.0
FCM1-100	40212	120	61.0'	100 SQ. FT.	1200	10.0

240V

MODEL	UPC	VOLTS	MAT LENGTH	HEATED AREA (20" WIDE)	WATTS	AMPS
FCM2-20	40213	240	12.2'	20 SQ. FT.	240	1.0
FCM2-25	40214	240	15.2'	25 SQ. FT.	300	1.3
FCM2-30	40215	240	18.3'	30 SQ. FT.	360	1.5
FCM2-35	40216	240	21.3'	35 SQ. FT.	420	1.8
FCM2-40	40217	240	24.4'	40 SQ. FT.	480	2.0
FCM2-50	40218	240	30.5'	50 SQ. FT.	600	2.5
FCM2-60	40219	240	36.6'	60 SQ. FT.	720	3.0
FCM2-70	40220	240	42.7'	70 SQ. FT.	840	3.5
FCM2-80	40221	240	48.8'	80 SQ. FT.	960	4.0
FCM2-90	40222	240	54.9'	90 SQ. FT.	1080	4.5
FCM2-100	40223	240	61.0'	100 SQ. FT.	1200	5.0
FCM2-110	40224	240	67.1'	110 SQ. FT.	1320	5.5
FCM2-120	40225	240	73.2'	120 SQ. FT.	1440	6.0
FCM2-145	40226	240	88.4'	145 SQ. FT.	1740	7.3
FCM2-160	40227	240	97.5'	160 SQ. FT.	1920	8.0

ACCESSORIES

-T Packaged with F902 GFCI Thermostat and Floor Sensor

-TA Packaged with F902 GFCI Thermostat, Floor Sensor and Cable Alarm

See FC/FCM Accessories page 5 for complete listing of accessories



Cable Alarm

Floor Sensor

F902 GFCI Thermostat

Thermostats

In-Floor Heating (3-3.7W/Ft.) & Thermal Storage (6W/Ft.)



**KING
F912GFCI
Slave**



**KING
F902GFCI
Programmable**



**OJ
UWG4-4999
WIFI Programmable**



**WARMUP
4IE04-BLACK/WHITE
WIFI Programmable**



**HONEYWELL/AUBE
TH115-AF-GA
Programmable**

King electronic thermostats are designed to achieve maximum comfort from King cable heating systems. Common feature to all models include:

- Three choices of temperature control: ambient air temperature, floor temperature or ambient air with floor limits.
- Advanced microprocessor optimizes performance by proportionally controlling the wattage to the cable saving energy and maintaining very accurate temperature control within $\pm 1^{\circ}\text{F}$, 0.5°C .
- Designed for maximum safety, they all include a ground-fault circuit interrupter (GFCI).
- A single touch activates the backlight display indicating the current set point.
- They are multi-volt and can be installed on 120, 208 and 240 volt circuits.

MODEL	UPC	DESCRIPTION
F912GFCI**	30759	King Recommended Slave Unit, 15 Amp, 5mA 120/208/240V, GFCI
F902GFCI**	30758	Electronic Programmable Floor Stat, 15 Amp, 5mA 120/208/240V, GFCI
UWG4-4999	42476	OJ Microline WIFI Touch Thermostat, 15A, 5mA, 120/240V, GFCI
4IE04-BL	42477	WARMUP Microline WIFI Smart Thermostat, 15A, 5mA, 120/240V, GFCI-Black
4IE04-WH	42478	WARMUP Microline WIFI Smart Thermostat, 15A, 5mA, 120/240V, GFCI-White
TH115-AF-GA	38983	Honeywell/Aube Electronic Programmable, 15 Amp, 5mA, 120/208/240V, GFCI

** Must use one F912GFCI slave unit to switch each heating load zone (15A per zone). Must be programmed and controlled by thermostat models F802GFCI or F902GFCI.

In-Floor Heating Accessories



**FCS1 Cable Strapping
(Included with Cable)**
For Use with FC Model Only.



**FCS13
(Repair Kit)**



**F8SENSOR
(King)**



**AC112-01/U
(Honeywell)**



**FCS11
(Cable Alarm)**

MODEL	UPC	DESCRIPTION
FCS11	40088	Heating Cable Monitor
FCS13	40092	Heating Cable Repair Kit
FCS1	40096	FC Cable Strapping
AC112-01/U	40094	Replacement Floor Sensor for Honeywell/Aube Thermostats
F8SENSOR	30761	Replacement Floor Sensor for King F902 GFCI Thermostats



Thermal Storage

Thermal Storage Heating Systems

King's Thermal Storage Heating systems are designed to warm the concrete slab of a building, creating a thermal mass that radiates heat into the building. King's system runs during off-peak hours, heating the floor to a consistent temperature, then shuts off during peak hours using the stored thermal heat to keep costs down.

TCM Series Mats offers the easiest solution to in-concrete thermal storage, providing pre-fabricated mats at 12W/SqFt (6" spacing) that can be rolled out prior to the concrete slab being poured. The Mat series was specifically designed for quick and easy installation.

TC Series Cable offers a custom layout solution to in-concrete thermal storage, that can be installed to fit any individual application. Cable can be spaced to allow between 12W/SqFt – 14W/SqFt (4", 5" or 6" spacing) depending on the application.

TC & TCM Concrete Installation

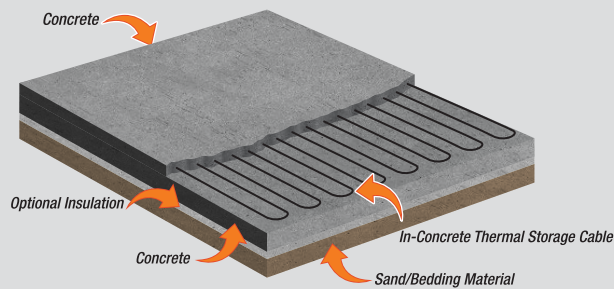

TC & TCM Sand Bed Installation

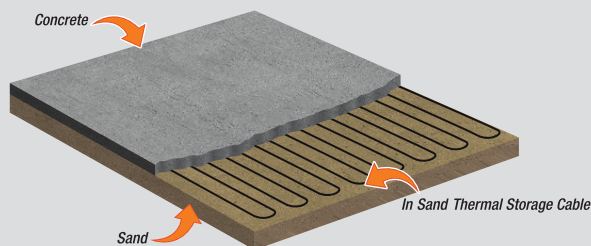

TC & TCM Cable Construction

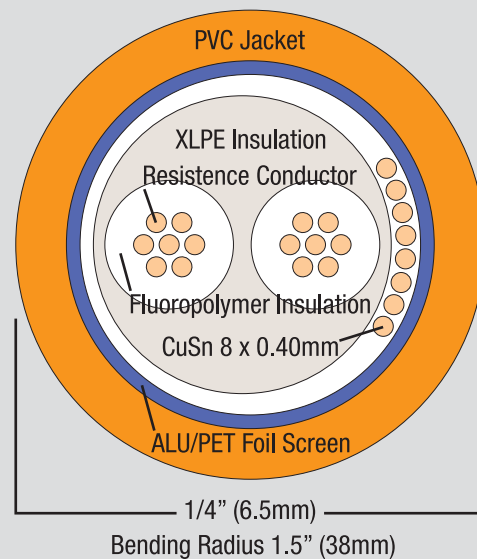

Thermal Storage Cable



Model Code:

TC 24 6 -60
A B C D

A: Thermal Storage Cable

B: 24 - 240V

C: Watts per foot

D: Linear Length in feet

TC Series Thermal Storage Cable is designed for a variety of floor heating applications, heating floors efficiently during on and off peak hours.

TC Thermal Storage Cable Features

- For use in concrete
- 6 Watts/Ft.
- 20 Ft. cold lead
- Tefzel® Insulation, PVC Jacket
- Emits zero EMFs (electromagnetic fields)
- Low operating costs, durable construction
- Single point connection, 10 year warranty
- Low memory design, cable stays flat



240V

MODEL	UPC	VOLTS	CABLE LENGTH		(5"SPACING-14W/SQ. FT.)	(6"SPACING-12W/SQ. FT.)	WATTS (6 W/FT.)	AMPS
TC246-60	42224	240	60 FT.	18.3 M	25 SQ. FT.	30 SQ. FT.	344	1.4
TC246-90	42225	240	90 FT.	27.4 M	35 SQ. FT.	45 SQ. FT.	515	2.1
TC246-115	42226	240	115 FT.	35.1 M	50 SQ. FT.	60 SQ. FT.	683	2.8
TC246-145	42227	240	145 FT.	44.2 M	60 SQ. FT.	75 SQ. FT.	852	3.6
TC246-175	42228	240	175 FT.	53.3 M	75 SQ. FT.	90 SQ. FT.	1026	4.3
TC246-210	42229	240	210 FT.	64.0 M	90 SQ. FT.	105 SQ. FT.	1226	5.1
TC246-240	42230	240	240 FT.	73.2 M	100 SQ. FT.	120 SQ. FT.	1395	5.8
TC246-300	42231	240	300 FT.	91.4 M	125 SQ. FT.	150 SQ. FT.	1735	7.2
TC246-355	42232	240	355 FT.	108.2 M	150 SQ. FT.	180 SQ. FT.	2072	8.6
TC246-415	42233	240	415 FT.	126.5 M	170 SQ. FT.	205 SQ. FT.	2410	10
TC246-470	42234	240	470 FT.	143.3 M	195 SQ. FT.	235 SQ. FT.	2756	11.5
TC246-530	42235	240	530 FT.	161.5 M	220 SQ. FT.	265 SQ. FT.	3097	12.9
TC246-595	42236	240	595 FT.	181.4 M	250 SQ. FT.	295 SQ. FT.	3470	14.5

More voltages available. Call for additional information

****GFCI Thermostats must always be used with King heating cable systems.**

TC & TCM Sand Bed Installation

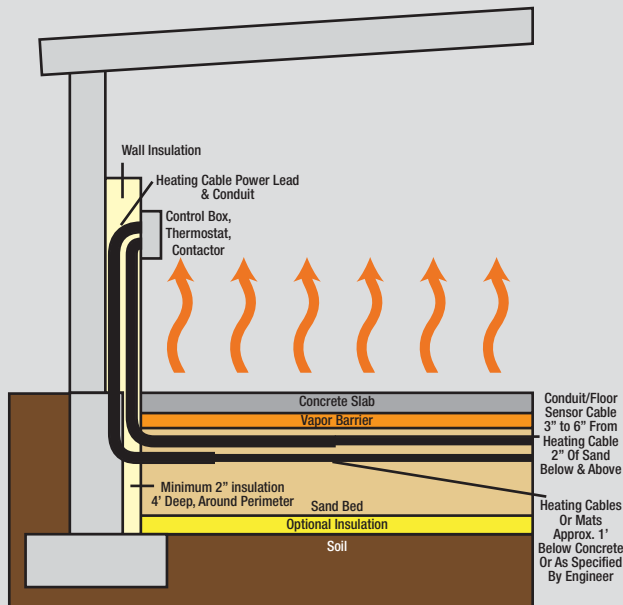

TC & TCM Concrete Installation

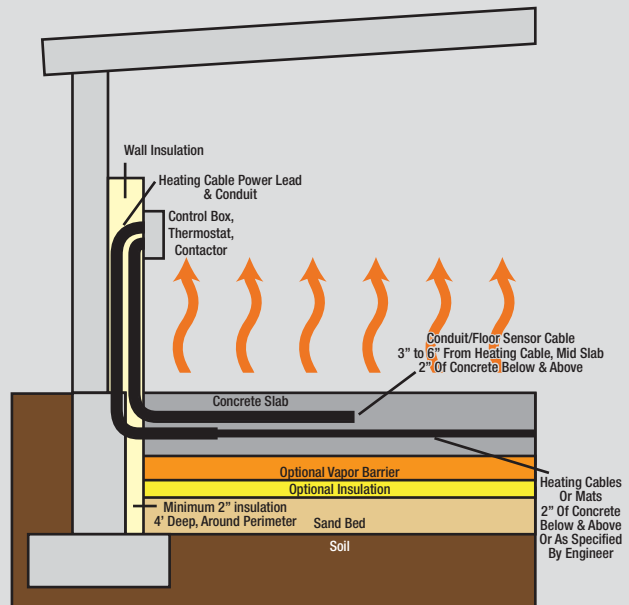

Thermal Storage Mats



Model Code:

TCM	24	14	24	-12
A	B	C	D	E
A: Thermal Storage Mat				
B: 24 - 240V				
C: Watts per Sq/Ft				
D: Width of Mat				
E: Mat Length				

TCM Series Thermal Storage Mat is designed for a variety of floor heating applications, heating floors efficiently during on and off peak hours.

TCM Thermal Storage 240V Mat Features

- For use in concrete/Single point connection
- 20 Ft. Cold Lead
- Low operating costs, 10 year warranty
- Emits zero EMFs (electromagnetic fields)
- Durable construction: Tefzel® Insulation, PVC Jacket
- Low memory design, cable stays flat



24" 240V

MODEL (24" WIDE)	UPC (093319)	MAT LENGTH	HEATED AREA (5" SPACING)	WATTS (14 W/FT²)	AMPS
TCM241424-12	42252	12.5 FT.	25.0 SQ. FT.	350	1.4
TCM241424-18	42253	18.8 FT.	37.5 SQ. FT.	525	2.1
TCM241424-24	42254	24.0 FT.	47.9 SQ. FT.	671	2.8
TCM241424-30	42255	30.2 FT.	60.4 SQ. FT.	846	3.6
TCM241424-36	42256	36.5 FT.	72.9 SQ. FT.	1021	4.3
TCM241424-43	42257	43.8 FT.	87.5 SQ. FT.	1225	5.1
TCM241424-50	42258	50.0 FT.	100.0 SQ. FT.	1400	5.8
TCM241424-62	42259	62.5 FT.	125.0 SQ. FT.	1750	7.2
TCM241424-74	42260	74.0 FT.	147.9 SQ. FT.	2071	8.6
TCM241424-86	42261	86.5 FT.	172.9 SQ. FT.	2421	10.0
TCM241424-97	42262	97.9 FT.	195.8 SQ. FT.	2742	11.5
TCM241424-110	42263	110.4 FT.	220.8 SQ. FT.	3092	12.9
TCM241424-124	42264	124.0 FT.	247.9 SQ. FT.	3471	14.5
TCM241424-141	42265	141.7 FT.	283.3 SQ. FT.	3966	16.6

MODEL (24" WIDE)	UPC (093319)	MAT LENGTH	HEATED AREA (6" SPACING)	WATTS (12 W/FT²)	AMPS
TCM241224-15	42238	15.0 FT.	30.0 SQ. FT.	360	1.4
TCM241224-22	42239	22.5 FT.	45.0 SQ. FT.	540	2.1
TCM241224-28	42240	28.8 FT.	57.5 SQ. FT.	690	2.8
TCM241224-36	42241	36.3 FT.	72.5 SQ. FT.	870	3.6
TCM241224-43	42242	43.8 FT.	87.5 SQ. FT.	1050	4.3
TCM241224-52	42243	52.5 FT.	105.0 SQ. FT.	1260	5.1
TCM241224-60	42244	60.0 FT.	120.0 SQ. FT.	1440	5.8
TCM241224-75	42245	75.0 FT.	150.0 SQ. FT.	1800	7.2
TCM241224-88	42246	88.8 FT.	177.5 SQ. FT.	2130	8.6
TCM241224-103	42247	103.8 FT.	207.5 SQ. FT.	2490	10.0
TCM241224-117	42248	117.5 FT.	235.0 SQ. FT.	2820	11.5
TCM241224-132	42249	132.5 FT.	265.0 SQ. FT.	3180	12.9
TCM241224-148	42250	148.8 FT.	297.5 SQ. FT.	3570	14.5
TCM241224-170	42251	170.0 FT.	340.0 SQ. FT.	4080	16.6

30" 240V

MODEL (30" WIDE)	UPC (093319)	MAT LENGTH	HEATED AREA (5" SPACING)	WATTS (14 W/FT²)	AMPS
TCM241430-10	42280	10.0 FT.	25.0 SQ. FT.	350	1.4
TCM241430-15	42281	15.0 FT.	37.5 SQ. FT.	525	2.1
TCM241430-19	42282	19.2 FT.	47.9 SQ. FT.	671	2.8
TCM241430-24	42283	24.2 FT.	60.4 SQ. FT.	846	3.6
TCM241430-29	42284	29.2 FT.	72.9 SQ. FT.	1021	4.3
TCM241430-35	42285	35.0 FT.	87.5 SQ. FT.	1225	5.1
TCM241430-40	42286	40.0 FT.	100.0 SQ. FT.	1400	5.8
TCM241430-50	42287	50.0 FT.	125.0 SQ. FT.	1750	7.2
TCM241430-59	42288	59.2 FT.	147.9 SQ. FT.	2071	8.6
TCM241430-69	42289	69.2 FT.	172.9 SQ. FT.	2421	10.0
TCM241430-78	42290	78.3 FT.	195.8 SQ. FT.	2742	11.5
TCM241430-88	42291	88.3 FT.	220.8 SQ. FT.	3092	12.9
TCM241430-99	42292	99.2 FT.	247.9 SQ. FT.	3471	14.5
TCM241430-113	42293	113.3 FT.	283.3 SQ. FT.	3966	16.6

MODEL (30" WIDE)	UPC (093319)	MAT LENGTH	HEATED AREA (6" SPACING)	WATTS (12 W/FT²)	AMPS
TCM241230-12	42266	12.0 FT.	30.0 SQ. FT.	360	1.4
TCM241230-18	42267	18.0 FT.	45.0 SQ. FT.	540	2.1
TCM241230-23	42268	23.0 FT.	57.5 SQ. FT.	690	2.8
TCM241230-29	42269	29.0 FT.	72.5 SQ. FT.	870	3.6
TCM241230-35	42270	35.0 FT.	87.5 SQ. FT.	1050	4.3
TCM241230-42	42271	42.0 FT.	105.0 SQ. FT.	1260	5.1
TCM241230-48	42272	48.0 FT.	120.0 SQ. FT.	1440	5.8
TCM241230-60	42273	60.0 FT.	150.0 SQ. FT.	1800	7.2
TCM241230-71	42274	71.0 FT.	177.5 SQ. FT.	2130	8.6
TCM241230-83	42275	83.0 FT.	207.5 SQ. FT.	2490	10.0
TCM241230-94	42276	94.0 FT.	235.0 SQ. FT.	2820	11.5
TCM241230-106	42277	106.0 FT.	265.0 SQ. FT.	3180	12.9
TCM241230-119	42278	119.0 FT.	297.5 SQ. FT.	3570	14.5
TCM241230-136	42279	136.0 FT.	340.0 SQ. FT.	4080	16.6

36" 240V

MODEL (36" WIDE)	UPC (093319)	MAT LENGTH	HEATED AREA (5" SPACING)	WATTS (14 W/FT²)	AMPS
TCM241436-8	42308	8.3 FT.	25.0 SQ. FT.	350	1.4
TCM241436-12	42309	12.5 FT.	37.5 SQ. FT.	525	2.1
TCM241436-16	42310	16.0 FT.	47.9 SQ. FT.	671	2.8
TCM241436-20	42311	20.1 FT.	60.4 SQ. FT.	846	3.6
TCM241436-24	42312	24.3 FT.	72.9 SQ. FT.	1021	4.3
TCM241436-29	42313	29.2 FT.	87.5 SQ. FT.	1225	5.1
TCM241436-33	42314	33.3 FT.	100.0 SQ. FT.	1400	5.8
TCM241436-41	42315	41.7 FT.	125.0 SQ. FT.	1750	7.2
TCM241436-49	42316	49.3 FT.	147.9 SQ. FT.	2071	8.6
TCM241436-57	42317	57.6 FT.	172.9 SQ. FT.	2421	10.0
TCM241436-65	42318	65.3 FT.	195.8 SQ. FT.	2742	11.5
TCM241436-73	42319	73.6 FT.	220.8 SQ. FT.	3092	12.9
TCM241436-82	42320	82.6 FT.	247.9 SQ. FT.	3471	14.5
TCM241436-94	42321	94.4 FT.	283.3 SQ. FT.	3967	16.6

MODEL (36" WIDE)	UPC (093319)	MAT LENGTH	HEATED AREA (6" SPACING)	WATTS (12 W/FT²)	AMPS
TCM241236-10	42294	10.0 FT.	30.0 SQ. FT.	360	1.4
TCM241236-15	42295	15.0 FT.	45.0 SQ. FT.	540	2.1
TCM241236-19	42296	19.2 FT.	57.5 SQ. FT.	690	2.8
TCM241236-24	42297	24.2 FT.	72.5 SQ. FT.	870	3.6
TCM241236-29	42298	29.2 FT.	87.5 SQ. FT.	1050	4.3
TCM241236-35	42299	35.0 FT.	105.0 SQ. FT.	1260	5.1
TCM241236-40	42300	40.0 FT.	120.0 SQ. FT.	1440	5.8
TCM241236-50	42301	50.0 FT.	150.0 SQ. FT.	1800	7.2
TCM241236-59	42302	59.2 FT.	177.5 SQ. FT.	2130	8.6
TCM241236-69	42303	69.2 FT.	207.5 SQ. FT.	2490	10.0
TCM241236-78	42304	78.3 FT.	235.0 SQ. FT.	2820	11.5
TCM241236-88	42305	88.3 FT.	265.0 SQ. FT.	3180	12.9
TCM241236-99	42306	99.2 FT.	297.5 SQ. FT.	3570	14.5
TCM241236-113	42307	113.3 FT.	340.0 SQ. FT.	4080	16.6

Snow Melt



Snow Melt Systems

King's Snow Melt Systems are great solutions to stay ahead of the snow and ice when winter arrives. On-demand snow melt improves the safety of driveways, sidewalks, stairs and other outdoor foot-traffic areas, keeping them free from the dangers of ice. Keep your home or business safe and accessible all year long.

SCM Series Mats offer the easiest solution to snow and ice build-up, providing pre-fabricated mats at 50W/SqFt (3" spacing) that can be rolled out prior to the concrete slab being poured. Whether you are heating concrete, asphalt or pavers the SCM will keep your area clear and safe to walk on.

SC Series Cable offers a custom in-concrete layout solution to snow and ice build-up, and can be installed to fit any individual application. Cable can be spaced to allow between 37W/Sq.Ft.-50W/Sq.Ft. (3" or 4" spacing) depending on the application. Heating concrete, asphalt or pavers with the SC will keep your area free from snow build up and formation of ice.

SC & SCM Concrete Installation

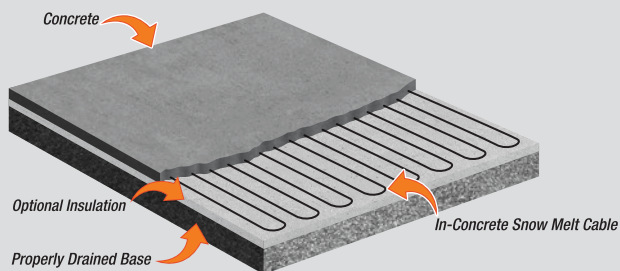

SC & SCM Asphalt/Paver Installation

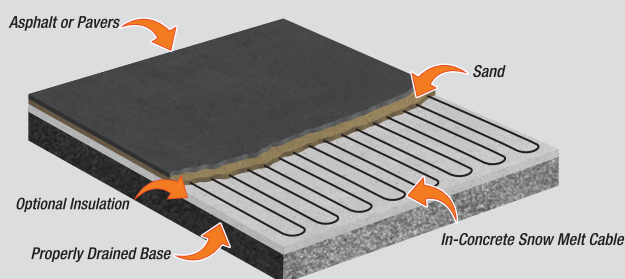

SC & SCM Cable Construction

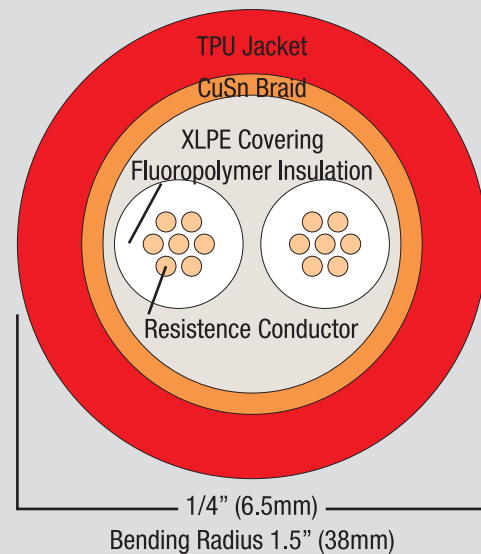

Snow Melt Cable



SC Series Snow Melt Cable is designed for a variety of cold weather applications, melting snow and ice for improved safety conditions.

SC Snow Melt Cable Features

- For use in concrete, asphalt and under pavers
- For use in sidewalks, driveways, stairs, ramps, etc.
- 20 Ft. Cold Lead
- Twin conductor
- Emits zero EMFs (electromagnetic fields)
- Single point connection, 10 year warranty
- Tefzel® Insulation, TPU Jacket

Model Code:

SC 20 12 -35
A B C D

A: Snow Melt Cable

B: 20 -208V

24 - 240V

48 - 480V

C: Watts per foot

D: Linear Length in feet

208V

MODEL	UPC	VOLTS	CABLE LENGTH		(3" SPACING-50W/SQ.FT.)	(4" SPACING-37W/SQ.FT.)	WATTS (12W/FT.)	AMPS
SC2012-35	42000	208	35 FT.	10.7 M	9 SQ. FT.	12 SQ. FT.	420	2.0
SC2012-50	42001	208	50 FT.	15.2 M	13 SQ. FT.	17 SQ. FT.	600	2.9
SC2012-70	42002	208	70 FT.	21.3 M	18 SQ. FT.	23 SQ. FT.	840	4.0
SC2012-85	42003	208	85 FT.	25.9 M	21 SQ. FT.	28 SQ. FT.	1020	4.9
SC2012-105	42004	208	105 FT.	32.0 M	26 SQ. FT.	35 SQ. FT.	1260	6.1
SC2012-125	42005	208	125 FT.	38.1 M	31 SQ. FT.	42 SQ. FT.	1500	7.2
SC2012-145	42006	208	145 FT.	44.2 M	36 SQ. FT.	48 SQ. FT.	1740	8.4
SC2012-160	42007	208	160 FT.	48.8 M	40 SQ. FT.	53 SQ. FT.	1920	9.2
SC2012-180	42008	208	180 FT.	54.9 M	45 SQ. FT.	60 SQ. FT.	2160	10.4
SC2012-210	42009	208	210 FT.	64.0 M	53 SQ. FT.	70 SQ. FT.	2520	12.1
SC2012-245	42010	208	245 FT.	74.7 M	61 SQ. FT.	82 SQ. FT.	2940	14.1
SC2012-280	42011	208	280 FT.	85.3 M	70 SQ. FT.	93 SQ. FT.	3360	16.2
SC2012-320	42012	208	320 FT.	97.5 M	80 SQ. FT.	107 SQ. FT.	3840	18.5
SC2012-355	42013	208	355 FT.	108.2 M	89 SQ. FT.	118 SQ. FT.	4220	20.5
SC2012-410	42014	208	410 FT.	125.0 M	103 SQ. FT.	137 SQ. FT.	4920	23.7
SC2012-460	42015	208	460 FT.	140.2 M	115 SQ. FT.	153 SQ. FT.	5520	26.5

240V

MODEL	UPC	VOLTS	CABLE LENGTH		(3" SPACING-50W/SQ.FT.)	(4" SPACING-37W/SQ.FT.)	WATTS (12W/FT.)	AMPS
SC2412-40	42016	240	40 FT.	12.2 M	10 SQ. FT.	13 SQ. FT.	480	2.0
SC2412-60	42017	240	60 FT.	18.3 M	15 SQ. FT.	20 SQ. FT.	720	3.0
SC2412-80	42018	240	80 FT.	24.4 M	20 SQ. FT.	27 SQ. FT.	960	4.0
SC2412-100	42019	240	100 FT.	30.5 M	25 SQ. FT.	33 SQ. FT.	1200	5.0
SC2412-120	42020	240	120 FT.	36.6 M	30 SQ. FT.	40 SQ. FT.	1440	6.0
SC2412-145	42021	240	145 FT.	44.2 M	36 SQ. FT.	48 SQ. FT.	1740	7.3
SC2412-165	42022	240	165 FT.	50.3 M	41 SQ. FT.	55 SQ. FT.	1980	8.3
SC2412-185	42023	240	185 FT.	56.4 M	46 SQ. FT.	62 SQ. FT.	2220	9.3
SC2412-205	42024	240	205 FT.	62.5 M	51 SQ. FT.	68 SQ. FT.	2460	10.3
SC2412-245	42025	240	245 FT.	74.7 M	61 SQ. FT.	82 SQ. FT.	2940	12.3
SC2412-285	42026	240	285 FT.	86.9 M	71 SQ. FT.	95 SQ. FT.	3420	14.3
SC2412-325	42027	240	325 FT.	99.1 M	81 SQ. FT.	108 SQ. FT.	3900	16.3
SC2412-370	42028	240	370 FT.	112.8 M	93 SQ. FT.	123 SQ. FT.	4440	18.5
SC2412-410	42029	240	410 FT.	125.0 M	103 SQ. FT.	137 SQ. FT.	4920	20.5
SC2412-475	42030	240	475 FT.	144.8 M	119 SQ. FT.	158 SQ. FT.	5700	23.8
SC2412-535	42031	240	535 FT.	163.1 M	134 SQ. FT.	178 SQ. FT.	6420	26.8

480V

MODEL	UPC	VOLTS	CABLE LENGTH		(3" SPACING-50W/SQ.FT.)	(4" SPACING-37W/SQ.FT.)	WATTS (12W/FT.)	AMPS
SC4812-80	42469	480	80 FT.	24.4 M	20 SQ. FT.	26.7 SQ. FT.	995	2.1
SC4812-200	42470	480	200 FT.	61.0 M	50 SQ. FT.	66.7 SQ. FT.	2460	5.1
SC4812-330	42471	480	330 FT.	100.6 M	82.5 SQ. FT.	110.0 SQ. FT.	4030	8.4
SC4812-490	42472	480	490 FT.	149.4 M	122.5 SQ. FT.	163.3 SQ. FT.	5990	12.5
SC4812-735	42473	480	735 FT.	224.0 M	183.8 SQ. FT.	245.0 SQ. FT.	8950	18.6
SC4812-820	42474	480	820 FT.	249.9 M	205.0 SQ. FT.	273.3 SQ. FT.	10010	20.9
SC4812-940	42475	480	940 FT.	286.5 M	235.0 SQ. FT.	313.3 SQ. FT.	11475	23.9

More voltages available. Call for additional information

Controls and thermostats should always be used with King heating cable systems.

ACCESSORIES

SCS1

25' Metal Cable Strapping for installation on existing concrete slab

Snow Melt Mats



Model Code:

SCM	20	48	24	-5
A	B	C	D	E
A: Snow Melt Mat				
B: 20 - 208V				
24 - 240V				
48 - 480V				
C: Watts per Sq/Ft				
D: Width of Mat				
E: Mat Length				

SCM Series Snow Melt Mat is designed for melting snow and ice for improved safety conditions.

SCM Snow Melt 208V Mat Features

- 20 Ft. Cold Lead, for use in concrete, asphalt & under pavers
- Single point connection, 10 year warranty
- Use in sidewalks, driveways, stairs, ramps, etc.
- Tefzel® Insulation, TPU Jacket, Emits zero EMFs

24" 208V

MODEL (24" WIDE)	UPC (093319)	MAT LENGTH	HEATED AREA (3" SPACING)	WATTS (48 W/FT²)	AMPS
SCM204824-4	42032	4.4 FT.	8.8 SQ. FT.	420	2.0
SCM204824-6	42033	6.3 FT.	12.5 SQ. FT.	600	2.9
SCM204824-8	42034	8.8 FT.	17.5 SQ. FT.	840	4.0
SCM204824-10	42035	10.6 FT.	21.3 SQ. FT.	1020	4.9
SCM204824-13	42036	13.1 FT.	26.3 SQ. FT.	1260	6.1
SCM204824-15	42037	15.6 FT.	31.3 SQ. FT.	1500	7.2
SCM204824-18	42038	18.1 FT.	36.3 SQ. FT.	1740	8.4
SCM204824-20	42039	20.0 FT.	40.0 SQ. FT.	1920	9.2
SCM204824-22	42040	22.5 FT.	45.0 SQ. FT.	2160	10.4
SCM204824-26	42041	26.3 FT.	52.5 SQ. FT.	2520	12.1
SCM204824-30	42042	30.6 FT.	61.3 SQ. FT.	2940	14.1
SCM204824-35	42043	35.0 FT.	70.0 SQ. FT.	3360	16.2
SCM204824-40	42044	40.0 FT.	80.0 SQ. FT.	3840	18.5
SCM204824-44	42045	44.4 FT.	88.8 SQ. FT.	4260	20.5
SCM204824-51	42046	51.3 FT.	102.5 SQ. FT.	4920	23.7
SCM204824-57	42047	57.5 FT.	115.0 SQ. FT.	5520	26.5

30" 208V

MODEL (30" WIDE)	UPC (093319)	MAT LENGTH	HEATED AREA (3" SPACING)	WATTS (48 W/FT²)	AMPS
SCM204830-3	42064	3.5 FT.	8.8 SQ. FT.	420	2.0
SCM204830-5	42065	5.0 FT.	12.5 SQ. FT.	600	2.9
SCM204830-7	42066	7.0 FT.	17.5 SQ. FT.	840	4.0
SCM204830-8	42067	8.5 FT.	21.3 SQ. FT.	1020	4.9
SCM204830-10	42068	10.5 FT.	26.3 SQ. FT.	1260	6.1
SCM204830-12	42069	12.5 FT.	31.3 SQ. FT.	1500	7.2
SCM204830-14	42070	14.5 FT.	36.3 SQ. FT.	1740	8.4
SCM204830-16	42071	16.0 FT.	40.0 SQ. FT.	1920	9.2
SCM204830-18	42072	18.0 FT.	45.0 SQ. FT.	2160	10.4
SCM204830-21	42073	21.0 FT.	52.5 SQ. FT.	2520	12.1
SCM204830-24	42074	24.5 FT.	61.3 SQ. FT.	2940	14.1
SCM204830-28	42075	28.0 FT.	70.0 SQ. FT.	3360	16.2
SCM204830-32	42076	32.0 FT.	80.0 SQ. FT.	3840	18.5
SCM204830-35	42077	35.5 FT.	88.8 SQ. FT.	4260	20.5
SCM204830-41	42078	41.0 FT.	102.5 SQ. FT.	4920	23.7
SCM204830-46	42079	46.0 FT.	115.0 SQ. FT.	5520	26.5

36" 208V

MODEL (36" WIDE)	UPC (093319)	MAT LENGTH	HEATED AREA (3" SPACING)	WATTS (48 W/FT²)	AMPS
SCM204836-2	42096	2.9 FT.	8.8 SQ. FT.	420	2.0
SCM204836-4	42097	4.2 FT.	12.5 SQ. FT.	600	2.9
SCM204836-5	42098	5.8 FT.	17.5 SQ. FT.	840	4.0
SCM204836-7	42099	7.1 FT.	21.3 SQ. FT.	1020	4.9
SCM204836-8	42100	8.8 FT.	26.3 SQ. FT.	1260	6.1
SCM204836-10	42101	10.4 FT.	31.3 SQ. FT.	1500	7.2
SCM204836-12	42102	12.1 FT.	36.3 SQ. FT.	1740	8.4
SCM204836-13	42103	13.3 FT.	40.0 SQ. FT.	1920	9.2
SCM204836-15	42104	15.0 FT.	45.0 SQ. FT.	2160	10.4
SCM204836-17	42105	17.5 FT.	52.5 SQ. FT.	2520	12.1
SCM204836-20	42106	20.4 FT.	61.3 SQ. FT.	2940	14.1
SCM204836-23	42107	23.3 FT.	70.0 SQ. FT.	3360	16.2
SCM204836-26	42108	26.7 FT.	80.0 SQ. FT.	3840	18.5
SCM204836-29	42109	29.6 FT.	88.8 SQ. FT.	4260	20.5
SCM204836-34	42110	34.2 FT.	102.5 SQ. FT.	4920	23.7
SCM204836-38	42111	38.3 FT.	115.0 SQ. FT.	5520	26.5

MODEL (24" WIDE)	UPC (093319)	MAT LENGTH	HEATED AREA (4" SPACING)	WATTS (36 W/FT²)	AMPS
SCM203624-5	42048	5.8 FT.	11.7 SQ. FT.	420	2.0
SCM203624-8	42049	8.3 FT.	16.7 SQ. FT.	600	2.9
SCM203624-11	42050	11.7 FT.	23.3 SQ. FT.	840	4.0
SCM203624-14	42051	14.2 FT.	28.3 SQ. FT.	1020	4.9
SCM203624-17	42052	17.5 FT.	35.0 SQ. FT.	1260	6.1
SCM203624-20	42053	20.8 FT.	41.7 SQ. FT.	1500	7.2
SCM203624-24	42054	24.2 FT.	48.3 SQ. FT.	1740	8.4
SCM203624-26	42055	26.7 FT.	53.3 SQ. FT.	1920	9.2
SCM203624-30	42056	30.0 FT.	60.0 SQ. FT.	2160	10.4
SCM203624-35	42057	35.0 FT.	70.0 SQ. FT.	2520	12.1
SCM203624-40	42058	40.8 FT.	81.7 SQ. FT.	2940	14.1
SCM203624-46	42059	46.7 FT.	93.3 SQ. FT.	3360	16.2
SCM203624-53	42060	53.3 FT.	106.7 SQ. FT.	3840	18.5
SCM203624-59	42061	59.2 FT.	118.3 SQ. FT.	4260	20.5
SCM203624-68	42062	68.3 FT.	136.7 SQ. FT.	4920	23.7
SCM203624-76	42063	76.7 FT.	153.3 SQ. FT.	5520	26.5

MODEL (30" WIDE)	UPC (093319)	MAT LENGTH	HEATED AREA (4" SPACING)	WATTS (36 W/FT²)	AMPS
SCM203630-4	42080	4.7 FT.	11.7 SQ. FT.	420	2.0
SCM203630-6	42081	6.7 FT.	16.7 SQ. FT.	600	2.9
SCM203630-9	42082	9.3 FT.	23.3 SQ. FT.	840	4.0
SCM203630-11	42083	11.3 FT.	28.3 SQ. FT.	1020	4.9
SCM203630-14	42084	14.0 FT.	35.0 SQ. FT.	1260	6.1
SCM203630-16	42085	16.7 FT.	41.7 SQ. FT.	1500	7.2
SCM203630-19	42086	19.3 FT.	48.3 SQ. FT.	1740	8.4
SCM203630-21	42087	21.3 FT.	53.3 SQ. FT.	1920	9.2
SCM203630-24	42088	24.0 FT.	60.0 SQ. FT.	2160	10.4
SCM203630-28	42089	28.0 FT.	70.0 SQ. FT.	2520	12.1
SCM203630-32	42090	32.7 FT.	81.7 SQ. FT.	2940	14.1
SCM203630-37	42091	37.3 FT.	93.3 SQ. FT.	3360	16.2
SCM203630-42	42092	42.7 FT.	106.7 SQ. FT.	3840	18.5
SCM203630-47	42093	47.3 FT.	118.3 SQ. FT.	4260	20.5
SCM203630-54	42094	54.7 FT.	136.7 SQ. FT.	4920	23.7
SCM203630-61	42095	61.3 FT.	153.3 SQ. FT.	5520	26.5

MODEL (36" WIDE)	UPC (093319)	MAT LENGTH	HEATED AREA (4" SPACING)	WATTS (36 W/FT²)	AMPS
SCM203636-3	42112	3.9 FT.	11.7 SQ. FT.	420	2.0
SCM203636-5	42113	5.6 FT.	16.7 SQ. FT.	600	2.9
SCM203636-7	42114	7.8 FT.	23.3 SQ. FT.	840	4.0
SCM203636-9	42115	9.4 FT.	28.3 SQ. FT.	1020	4.9
SCM203636-11	42116	11.7 FT.	35.0 SQ. FT.	1260	6.1
SCM203636-13	42117	13.9 FT.	41.7 SQ. FT.	1500	7.2
SCM203636-16	42118	16.1 FT.	48.3 SQ. FT.	1740	8.4
SCM203636-17	42119	17.8 FT.	53.3 SQ. FT.	1920	9.2
SCM203636-20	42120	20.0 FT.	60.0 SQ. FT.	2160	10.4
SCM203636-23	42121	23.3 FT.	70.0 SQ. FT.	2520	12.1
SCM203636-27	42122	27.2 FT.	81.7 SQ. FT.	2940	14.1
SCM203636-31	42123	31.1 FT.	93.3 SQ. FT.	3360	16.2
SCM203636-35	42124	35.6 FT.	106.7 SQ. FT.	3840	18.5
SCM203636-39	42125	39.4 FT.	118.3 SQ. FT.	4260	20.5
SCM203636-45	42126	45.6 FT.	136.7 SQ. FT.	4920	23.7
SCM203636-51	42127	51.1 FT.	153.3 SQ. FT.	5520	26.5

Snow Melt Mats



SCM Series Snow Melt Mat is designed for melting snow and ice for improved safety conditions.

SCM Snow Melt 240V Mat Features

- 20 Ft. Cold Lead, for use in concrete, asphalt & under pavers
- 10 year warranty, Emits zero EMFs (electromagnetic fields)
- Use in sidewalks, driveways, stairs, ramps, etc.
- Single point connection, Tefzel® Insulation, TPU Jacket



Model Code:

SCM	20	48	24	-5
A	B	C	D	E
A: Snow Melt Mat				
B: 20 - 208V				
24 - 240V				
48 - 480V				
C: Watts per Sq/Ft				
D: Width of Mat				
E: Mat Length				

	MODEL	UPC	MAT	HEATED AREA	WATTS		MODEL	UPC	MAT	HEATED AREA	WATTS	
	(24" WIDE)	(093319)	LENGTH	(3" SPACING)	(48 W/FT²)		AMPS	(24" WIDE)	(093319)	LENGTH	(4" SPACING)	(36 W/FT²)
24" 240V	SCM244824-5	42128	5.0 FT.	10.0 SQ. FT.	480	2.0	SCM243624-6	42144	6.7 FT.	13.3 SQ. FT.	480	2.0
	SCM244824-7	42129	7.5 FT.	15.0 SQ. FT.	720	3.0	SCM243624-10	42145	10.0 FT.	20.0 SQ. FT.	720	3.0
	SCM244824-10	42130	10.0 FT.	20.0 SQ. FT.	960	4.0	SCM243624-13	42146	13.3 FT.	26.7 SQ. FT.	960	4.0
	SCM244824-12	42131	12.5 FT.	25.0 SQ. FT.	1200	5.0	SCM243624-16	42147	16.7 FT.	33.3 SQ. FT.	1200	5.0
	SCM244824-15	42132	15.0 FT.	30.0 SQ. FT.	1440	6.0	SCM243624-20	42148	20.0 FT.	40.0 SQ. FT.	1440	6.0
	SCM244824-18	42133	18.1 FT.	36.3 SQ. FT.	1740	7.3	SCM243624-24	42149	24.2 FT.	48.3 SQ. FT.	1740	7.3
	SCM244824-20	42134	20.6 FT.	41.3 SQ. FT.	1980	8.3	SCM243624-27	42150	27.5 FT.	55.0 SQ. FT.	1980	8.3
	SCM244824-23	42135	23.1 FT.	46.3 SQ. FT.	2220	9.3	SCM243624-30	42151	30.8 FT.	61.7 SQ. FT.	2220	9.3
	SCM244824-25	42136	25.6 FT.	51.3 SQ. FT.	2460	10.3	SCM243624-34	42152	34.2 FT.	68.3 SQ. FT.	2460	10.3
	SCM244824-30	42137	30.6 FT.	61.3 SQ. FT.	2940	12.3	SCM243624-40	42153	40.8 FT.	81.7 SQ. FT.	2940	12.3
	SCM244824-35	42138	35.6 FT.	71.3 SQ. FT.	3420	14.3	SCM243624-47	42154	47.5 FT.	95.0 SQ. FT.	3420	14.3
	SCM244824-40	42139	40.6 FT.	81.3 SQ. FT.	3900	16.3	SCM243624-54	42155	54.2 FT.	108.3 SQ. FT.	3900	16.3
	SCM244824-46	42140	46.3 FT.	92.5 SQ. FT.	4440	18.5	SCM243624-61	42156	61.7 FT.	123.3 SQ. FT.	4440	18.5
	SCM244824-51	42141	51.3 FT.	102.5 SQ. FT.	4920	20.5	SCM243624-68	42157	68.3 FT.	136.7 SQ. FT.	4920	20.5
	SCM244824-59	42142	59.4 FT.	118.8 SQ. FT.	5700	23.8	SCM243624-79	42158	79.2 FT.	158.3 SQ. FT.	5700	23.8
	SCM244824-66	42143	66.9 FT.	133.8 SQ. FT.	6420	26.8	SCM243624-89	42159	89.2 FT.	178.3 SQ. FT.	6420	26.8
		MODEL	UPC	MAT	HEATED AREA	WATTS		MODEL	UPC	MAT	HEATED AREA	WATTS
		(30" WIDE)	(093319)	LENGTH	(3" SPACING)	(48 W/FT²)		AMPS	(30" WIDE)	(093319)	LENGTH	(4" SPACING)
30" 240V	SCM244830-4	42160	4.0 FT.	10.0 SQ. FT.	480	2.0	SCM243630-5	42176	5.3 FT.	13.3 SQ. FT.	480	2.0
	SCM244830-6	42161	6.0 FT.	15.0 SQ. FT.	720	3.0	SCM243630-8	42177	8.0 FT.	20.0 SQ. FT.	720	3.0
	SCM244830-8	42162	8.0 FT.	20.0 SQ. FT.	960	4.0	SCM243630-10	42178	10.7 FT.	26.7 SQ. FT.	960	4.0
	SCM244830-10	42163	10.0 FT.	25.0 SQ. FT.	1200	5.0	SCM243630-13	42179	13.3 FT.	33.3 SQ. FT.	1200	5.0
	SCM244830-12	42164	12.0 FT.	30.0 SQ. FT.	1440	6.0	SCM243630-16	42180	16.0 FT.	40.0 SQ. FT.	1440	6.0
	SCM244830-14	42165	14.5 FT.	36.3 SQ. FT.	1740	7.3	SCM243630-19	42181	19.3 FT.	48.3 SQ. FT.	1740	7.3
	SCM244830-16	42166	16.5 FT.	41.3 SQ. FT.	1980	8.3	SCM243630-22	42182	22.0 FT.	55.0 SQ. FT.	1980	8.3
	SCM244830-18	42167	18.5 FT.	46.3 SQ. FT.	2220	9.3	SCM243630-24	42183	24.7 FT.	61.7 SQ. FT.	2220	9.3
	SCM244830-20	42168	20.5 FT.	51.3 SQ. FT.	2460	10.3	SCM243630-27	42184	27.3 FT.	68.3 SQ. FT.	2460	10.3
	SCM244830-24	42169	24.5 FT.	61.3 SQ. FT.	2940	12.3	SCM243630-32	42185	32.7 FT.	81.7 SQ. FT.	2940	12.3
	SCM244830-28	42170	28.5 FT.	71.3 SQ. FT.	3420	14.3	SCM243630-38	42186	38.0 FT.	95.0 SQ. FT.	3420	14.3
	SCM244830-32	42171	32.5 FT.	81.3 SQ. FT.	3900	16.3	SCM243630-43	42187	43.3 FT.	108.3 SQ. FT.	3900	16.3
	SCM244830-37	42172	37.0 FT.	92.5 SQ. FT.	4440	18.5	SCM243630-49	42188	49.3 FT.	123.3 SQ. FT.	4440	18.5
	SCM244830-41	42173	41.0 FT.	102.5 SQ. FT.	4920	20.5	SCM243630-54	42189	54.7 FT.	136.7 SQ. FT.	4920	20.5
	SCM244830-47	42174	47.5 FT.	118.8 SQ. FT.	5700	23.8	SCM243630-69	42190	63.3 FT.	158.3 SQ. FT.	5700	23.8
	SCM244830-53	42175	53.5 FT.	133.8 SQ. FT.	6420	26.8	SCM243630-71	42191	71.3 FT.	178.3 SQ. FT.	6420	26.8
		MODEL	UPC	MAT	HEATED AREA	WATTS		MODEL	UPC	MAT	HEATED AREA	WATTS
		(36" WIDE)	(093319)	LENGTH	(3" SPACING)	(48 W/FT²)		AMPS	(36" WIDE)	(093319)	LENGTH	(4" SPACING)
36" 240V	SCM244836-3	42192	3.3 FT.	10.0 SQ. FT.	480	2.0	SCM243636-4	42208	4.4 FT.	13.3 SQ. FT.	480	2.0
	SCM244836-5	42193	5.0 FT.	15.0 SQ. FT.	720	3.0	SCM243636-6	42209	6.7 FT.	20.0 SQ. FT.	720	3.0
	SCM244836-6	42194	6.7 FT.	20.0 SQ. FT.	960	4.0	SCM243636-8	42210	8.9 FT.	26.7 SQ. FT.	960	4.0
	SCM244836-8	42195	8.3 FT.	25.0 SQ. FT.	1200	5.0	SCM243636-11	42211	11.1 FT.	33.3 SQ. FT.	1200	5.0
	SCM244836-10	42196	10.0 FT.	30.0 SQ. FT.	1440	6.0	SCM243636-13	42212	13.3 FT.	40.0 SQ. FT.	1440	6.0
	SCM244836-12	42197	12.1 FT.	36.3 SQ. FT.	1740	7.3	SCM243636-16	42213	16.1 FT.	48.3 SQ. FT.	1740	7.3
	SCM244836-13	42198	13.8 FT.	41.3 SQ. FT.	1980	8.3	SCM243636-18	42214	18.3 FT.	55.0 SQ. FT.	1980	8.3
	SCM244836-15	42199	15.4 FT.	46.3 SQ. FT.	2220	9.3	SCM243636-20	42215	20.6 FT.	61.7 SQ. FT.	2220	9.3
	SCM244836-17	42200	17.1 FT.	51.3 SQ. FT.	2460	10.3	SCM243636-22	42216	22.8 FT.	68.3 SQ. FT.	2460	10.3
	SCM244836-20	42201	20.4 FT.	61.3 SQ. FT.	2940	12.3	SCM243636-27	42217	27.2 FT.	81.7 SQ. FT.	2940	12.3
	SCM244836-23	42202	23.8 FT.	71.3 SQ. FT.	3420	14.3	SCM243636-31	42218	31.7 FT.	95.0 SQ. FT.	3420	14.3
	SCM244836-27	42203	27.1 FT.	81.3 SQ. FT.	3900	16.3	SCM243636-36	42219	36.1 FT.	108.3 SQ. FT.	3900	16.3
	SCM244836-30	42204	30.8 FT.	92.5 SQ. FT.	4440	18.5	SCM243636-41	42220	41.1 FT.	123.3 SQ. FT.	4440	18.5
	SCM244836-34	42205	34.2 FT.	102.5 SQ. FT.	4920	20.5	SCM243636-45	42221	45.6 FT.	136.7 SQ. FT.	4920	20.5
	SCM244836-39	42206	39.6 FT.	118.8 SQ. FT.	5700	23.8	SCM243636-52	42222	52.8 FT.	158.3 SQ. FT.	5700	23.8
	SCM244836-44	42207	44.6 FT.	133.8 SQ. FT.	6420	26.8	SCM243636-59	42223	59.4 FT.	178.3 SQ. FT.	6420	26.8

Snow Melt Mats



Model Code:

SCM	20	48	24	-5
A	B	C	D	E
A: Snow Melt Mat				
B: 20 - 208V				
24 - 240V				
48 - 480V				
C: Watts per Sq/Ft				
D: Width of Mat				
E: Mat Length				



SCM Series Snow Melt Mat is designed for melting snow and ice for improved safety conditions.

SCM Snow Melt 480V Mat Features

- 20 Ft. Cold Lead, for use in concrete, asphalt & under pavers
- 10 year warranty, Emits zero EMFs (electromagnetic fields)
- Use in sidewalks, driveways, stairs, ramps, etc.
- Single point connection, Tefzel® Insulation, TPU Jacket

	MODEL	UPC	MAT	HEATED AREA	WATTS		MODEL	UPC	MAT	HEATED AREA	WATTS	
	(24" WIDE)	(093319)	LENGTH	(3" SPACING)	(48 W/FT²)		AMPS	(24" WIDE)	(093319)	LENGTH	(4" SPACING)	(36 W/FT²)
24" 480V	SCM484824-10	42448	10.0 FT.	20.0 SQ. FT.	960	2.1	SCM483624-13	42427	13.3 FT.	26.7 SQ. FT.	960	2.1
	SCM484824-25	42449	25.0 FT.	50.0 SQ. FT.	2400	5.1	SCM483624-33	42428	33.3 FT.	66.7 SQ. FT.	2400	5.1
	SCM484824-41	42450	41.3 FT.	82.5 SQ. FT.	3960	8.4	SCM483624-55	42429	55.0 FT.	110.0 SQ. FT.	3960	8.4
	SCM484824-61	42451	61.3 FT.	122.5 SQ. FT.	5880	12.5	SCM483624-81	42430	81.7 FT.	163.3 SQ. FT.	5880	12.5
	SCM484824-91	42452	91.9 FT.	183.8 SQ. FT.	8820	18.6	SCM483624-122	42431	122.5 FT.	245.0 SQ. FT.	8820	18.6
	SCM484824-102	42453	102.5 FT.	205.0 SQ. FT.	9840	20.9	SCM483624-136	42432	136.7 FT.	273.3 SQ. FT.	9840	20.9
	SCM484824-117	42454	117.5 FT.	235.0 SQ. FT.	11280	23.9	SCM483624-156	42433	156.7 FT.	313.3 SQ. FT.	11280	23.9
30" 480V	MODEL	UPC	MAT	HEATED AREA	WATTS		MODEL	UPC	MAT	HEATED AREA	WATTS	
	(30" WIDE)	(093319)	LENGTH	(3" SPACING)	(48 W/FT²)		AMPS	(30" WIDE)	(093319)	LENGTH	(4" SPACING)	(36 W/FT²)
	SCM484830-82	42455	8.0 FT.	20.0 SQ. FT.	960	2.1	SCM483630-10	42434	10.7 FT.	26.7 SQ. FT.	960	2.1
	SCM484830-20	42456	20.0 FT.	50.0 SQ. FT.	2400	5.1	SCM483630-26	42435	26.7 FT.	66.7 SQ. FT.	2400	5.1
	SCM484830-33	42457	33.0 FT.	82.5 SQ. FT.	3960	8.4	SCM483630-44	42436	44.0 FT.	110.0 SQ. FT.	3960	8.4
	SCM484830-49	42458	49.0 FT.	122.5 SQ. FT.	5880	12.5	SCM483630-65	42437	65.3 FT.	163.3 SQ. FT.	5880	12.5
	SCM484830-73	42459	73.0 FT.	183.8 SQ. FT.	8820	18.6	SCM483630-98	42438	98.0 FT.	245.0 SQ. FT.	8820	18.6
SCM484830-82	42160	82.0 FT.	205.0 SQ. FT.	9840	20.9	SCM483630-109	42439	109.3 FT.	273.3 SQ. FT.	9840	20.9	
SCM484830-94	42461	94.0 FT.	235.0 SQ. FT.	11280	23.9	SCM483630-125	42440	125.3 FT.	313.3 SQ. FT.	11280	23.9	
36" 480V	MODEL	UPC	MAT	HEATED AREA	WATTS		MODEL	UPC	MAT	HEATED AREA	WATTS	
	(36" WIDE)	(093319)	LENGTH	(3" SPACING)	(48 W/FT²)		AMPS	(36" WIDE)	(093319)	LENGTH	(4" SPACING)	(36 W/FT²)
	SCM484836-6	42462	6.7 FT.	20.0 SQ. FT.	960	2.1	SCM483636-8	42441	8.9 FT.	26.7 SQ. FT.	960	2.1
	SCM484836-16	42463	16.7 FT.	50.0 SQ. FT.	2400	5.1	SCM483636-22	42442	22.2 FT.	66.7 SQ. FT.	2400	5.1
	SCM484836-27	42464	27.5 FT.	82.5 SQ. FT.	3960	8.4	SCM483636-36	42443	36.7 FT.	110.0 SQ. FT.	3960	8.4
	SCM484836-40	42465	40.8 FT.	122.5 SQ. FT.	5880	12.5	SCM483636-54	42444	54.4 FT.	163.3 SQ. FT.	5880	12.5
	SCM484836-61	42466	61.3 FT.	183.8 SQ. FT.	8820	18.6	SCM483636-81	42445	81.7 FT.	245.0 SQ. FT.	8820	18.6
	SCM484836-68	42467	68.3 FT.	205.0 SQ. FT.	9840	20.9	SCM483636-91	42446	91.1 FT.	273.3 SQ. FT.	9840	20.9
SCM484836-78	42468	78.3 FT.	235.0 SQ. FT.	11280	23.9	SCM483636-104	42447	104.4 FT.	313.3 SQ. FT.	11280	23.9	

More voltages available. Call for additional information

****Controls and thermostats should always be used with King heating cable systems.**

Pipe Freeze Protection



Pipe Freeze Protection Systems

King's Pipe Freeze Protection systems ensure that your pipes remain clear of ice and water continues to flow all winter long. Easy installation makes the process go quickly so you can be prepared long before winter arrives. Perfect for residential, commercial or industrial applications.

SRP Series Self-Regulating Pre-Assembled Heating Cable is designed for a variety of pipe freeze protection applications. The cable is constructed so that it will not burn out or overheat when overlapped, and can be used on metal and plastic pipes. The cable is pre-terminated with a 30 inch cold lead.

SR Series Self-Regulating Heating Cable is designed for commercial and industrial pipe trace applications. The cable is constructed so that it will not burn out or overheat when overlapped, and can be used on metal and plastic pipes. The cable is available in 100 and 250 ft coils and also 500 and 1,000 ft reels.

CWP Series Constant Wattage Pipe Trace Heating Cable is designed to prevent pipes from freezing, keeping water flowing down to -40°F . Operating at 7W per linear foot, it has an integrated energy-saving thermostat for efficient use and a power indicator light in the plug. The CWP is pre-assembled and ready to install on metal and plastic pipes.

SR/SRP Cable



Cable Construction Table

Outer Jacket	Rugged polyolefin UV jacket
Outer Jacket (-CT)*	Fluoropolymer jacket
Ground Braid	Tinned copper
Inner Jacket	Flame retardent thermoplastic
Core	Self-regulating semi-conductive core
Bus Wire	16 gauge tinned copper
Bending Radius	1" (24mm)

SR/SRP Application

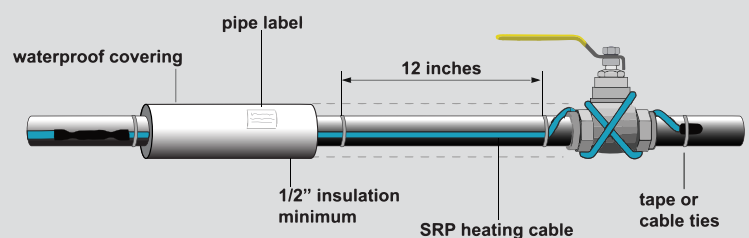

CWP Application



Pre-Assembled Self-Regulating Pipe Trace Cable

Pre-Assembled



120 Volt - Grounded Plug



Model Code:

SCM 12 6 -6
A B C D

A: Pre-Assembled Self Reg.
B: 12 - 120V
24 - 240V
C: Watts per foot
D: Linear Length in feet

SRP Series Self-Regulating Pre-Assembled Heating Cable is designed for a variety of pipe freeze protection applications.

SRP Self-Regulating Pre-Assembled Heating Cable Features

- Pre-terminated with 30 inch grounded plug and end splice
- Suitable for use on metal and plastic pipes
- 2 year warranty
- Cable will not overheat or burn out when overlapped
- 16 gauge heating cable bus wire
- 6 w/ft at 40°F (5°C)



120V

MODEL	UPC	LENGTH	VOLTS	WATTS*
SRP126-6	40400	6 FT.	120	36
SRP126-12	40402	12 FT.	120	72
SRP126-18	40404	18 FT.	120	108
SRP126-24	40406	24 FT.	120	144
SRP126-37	48711	37.5 FT.	120	225
SRP126-50	40408	50 FT.	120	300
SRP126-62	48712	62.5 FT.	120	375
SRP126-75	40410	75 FT.	120	450
SRP126-87	48713	87.5 FT.	120	525
SRP126-100	40412	100 FT.	120	600
SRP126-125	48714	125 FT.	120	750
SRP126-150	48715	150 FT.	120	900

*Wattage rating for pipe freeze protection application is 6 w/ft determined at 40°F (5°C).



240V - Cold Leads



SRP Series Self-Regulating Pre-Assembled Heating Cable is designed for a variety of pipe freeze protection applications.

SRP Self-Regulating Pre-Assembled Heating Cable Features

- Pre-terminated with 30 inch grounded plug and end splice
- Suitable for use on metal and plastic pipes
- 2 year warranty
- Cable will not overheat or burn out when overlapped
- 16 gauge heating cable bus wire
- 6 w/ft at 40°F (5°C)



240V

MODEL	UPC	LENGTH	VOLTS	WATTS*
SRP246-6	42373	6 FT.	240	36
SRP246-12	42374	12 FT.	240	72
SRP246-18	42375	18 FT.	240	108
SRP246-24	42376	24 FT.	240	144
SRP246-37	48716	37.5 FT.	240	225
SRP246-50	42377	50 FT.	240	300
SRP246-62	48717	62.5 FT.	240	375
SRP246-75	42378	75 FT.	240	450
SRP246-87	48718	87.5 FT.	240	525
SRP246-100	42379	100 FT.	240	600
SRP246-125	48719	125 FT.	240	750
SRP246-150	48720	150 FT.	240	900
SRP246-175	48721	175 FT.	240	1050
SRP246-200	48722	200 FT.	240	1200

*Wattage rating for pipe freeze protection application is 6 w/ft determined at 40°F (5°C).

Constant Wattage Pipe Trace Cable



Model Code:

CWP 021 -3
A B C

A: Constant Wattage
B: Watts
C: Linear Length in feet

CWP Series Constant Wattage Pipe Freeze Protection Cable is designed to prevent pipes from freezing, keeping water flowing to -40°F.

CWP Constant Wattage Pipe Trace Heating Cable Features

- Stops pipe and valve freeze down to -40°F
- Integrated energy-saving thermostat
- Power indicator light in plug
- Pre-assembled and ready to install
- For metal and plastic pipes
- 1 year warranty



120V

MODEL	UPC	LENGTH	VOLTS	WATTS (7 W/FT.)	AMPS
CWP021-3	48634	3 FT.	120	21	0.2
CWP042-6	48635	6 FT.	120	42	0.4
CWP063-9	48636	9 FT.	120	63	0.5
CWP084-12	48637	12 FT.	120	84	0.7
CWP105-15	48638	15 FT.	120	105	0.9
CWP126-18	48639	18 FT.	120	126	1.1
CWP168-24	48640	24 FT.	120	168	1.4
CWP210-30	48641	30 FT.	120	210	1.8
CWP280-40	48642	40 FT.	120	280	2.3
CWP420-60	48643	60 FT.	120	420	3.5
CWP560-80	48644	80 FT.	120	560	4.7

****NOTE: Do not overlap cable.**

MODEL	UPC	CWP ACCESSORIES
SRK03	40464	Pipe trace tape (66 ft) and labels

Simply run cable straight along pipe and valves, securing every 6" with quality electrical tape. Plug into a **GFCI** (ground fault protected) electrical outlet and system is ready for use.

Pipe Selection: To select the correct length cable(s) for your application, you must first determine the **Length** and **Diameter** of the pipe to be heated (including valves).

Refer to **Cable Selection Guide** to determine the cable length(s) required for your specific application. Then select the King model number with matching length(s).

Cable length is determined as follows:

For Pipe 3/4" or less in diameter: Round pipe length down to the nearest 3-foot increment. Cable can be up to 2 feet shorter than pipe.

For Pipe 1" to 1-1/2" in diameter: Cable can not be run shorter than pipe length. Overrun should not exceed 3 feet.

CABLE SELECTION GUIDE

LENGTH OF PIPE		3/8"-3/4"	3'	4-5'	6'	7-8'	9'	10-11'	12'	13-14'	15'	16-17'	18'	19-20'	21-23'	24'	25-27'	28-29'	30'	40'	60'	80'
DIA	(9.53-19.05mm)	0.9m	1.2-1.5m	1.8m	2.1-2.4m	2.7m	3-3.4m	3.7m	4-4.3m	4.6m	4.9-5.2m	5.5m	5.8-6.1m	6.4-7m	7.3m	7.6-8.2m	8.5-8.8m	9.1m	12.2m	18.3m	24.4	
Select Cable Length (ft.)		3'	3'	6'	6'	9'	9'	12'	12'	15'	15'	18'	18'	(2pcs) 12'	24'	24'	(2pcs) 15'	30'	40'	60'	80'	

LENGTH OF PIPE		1"-1 1/2"	3'	4-5'	6'	7-8'	9'	10-11'	12'	13-14'	15'	16-17'	18'	19-20'	21-23'	24'	25-27'	28-29'	30'	40'	60'	80'
DIA	(25.4-38.1mm)	0.9m	1.2-1.5m	1.8m	2.1-2.4m	2.7m	3-3.4m	3.7m	4-4.3m	4.6m	4.9-5.2m	5.5m	5.8-6.1m	6.4-7m	7.3m	7.6-8.2m	8.5-8.8m	9.1m	12.2m	18.3m	24.4	
Select Cable Length (ft.)		3'	(2pcs) 3'	6'	(1pc) 3' & (1pc) 6'	9'	(2pcs) 6'	12'	(1pc) 6' & (1pc) 9'	15'	(2pcs) 9'	18'	(1pc) 9' & (1pc) 12'	(2pcs) 12'	24'	(1pc) 12' & (1pc) 15'	(2pcs) 15'	30'	40'	60'	80'	

NOTE: For pipe diameter 3/8" to 3/4" only, cable can be up to 2 ft. shorter than pipe length.

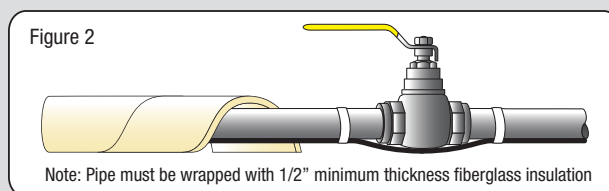
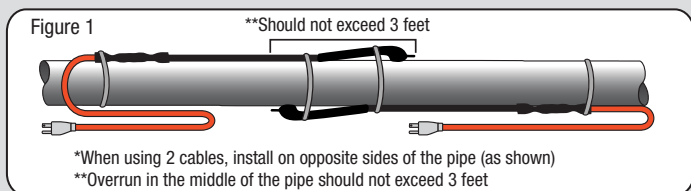

Self-Regulating Pipe Trace Cable

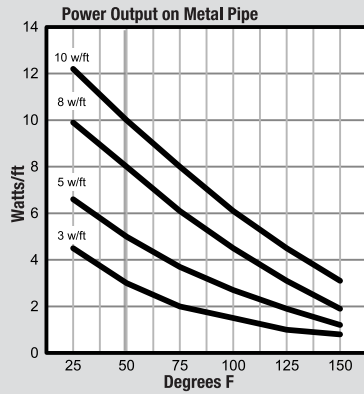

1,000 ft. Reel

Model Code:

SR 12 3 -250
A B C D

A: Self Regulating Cable

B: 12 - 120V

24 - 240V

C: Watts per foot

D: Linear Length in feet

SR Series Self-Regulating Heating Cable is designed for a variety of industrial and commercial pipe trace applications.

SR Self-Regulating Heating Cable Features

- Stops pipe and valve freeze down to -40°F
- Cable will not overheat or burn out when overlapped
- Suitable for use on metal and plastic pipes
- 2 year warranty



AVAILABLE LENGTHS

	VOLTS	PIPE RATING** WATTS/FT.	100 FT. LENGTH MODEL / UPC	250 FT. LENGTH MODEL / UPC	500 FT. LENGTH MODEL / UPC	1000 FT. LENGTH MODEL / UPC	WEIGHT/FT.
120V	120	3	SR123-100 / 40513	SR123-250 / 40414	SR123-500 / 48735	SR123-1000 / 40416	0.080 LBS./FT.
	120	5	SR125-100 / 40514	SR125-250 / 40418	SR125-500 / 48736	SR125-1000 / 40420	0.080 LBS./FT.
	120	8	SR128-100 / 40515	SR128-250 / 40422	SR128-500 / 48737	SR128-1000 / 40424	0.080 LBS./FT.
	120	10	SR1210-100 / 40516	SR1210-250 / 40426	SR1210-500 / 48742	SR1210-1000 / 40428	0.080 LBS./FT.
240V	240*	3	SR243-100 / 40517	SR243-250 / 40430	SR243-500 / 48739	SR243-1000 / 40432	0.080 LBS./FT.
	240*	5	SR245-100 / 40518	SR245-250 / 40434	SR245-500 / 48740	SR245-1000 / 40436	0.080 LBS./FT.
	240*	8	SR248-100 / 40519	SR248-250 / 40438	SR248-500 / 48741	SR248-1000 / 40440	0.080 LBS./FT.
	240*	10	SR2410-100 / 40520	SR2410-250 / 40442	SR2410-500 / 48746	SR2410-1000 / 40444	0.080 LBS./FT.

**Wattage rating for pipe freeze protection application is determined at 50°F (10°C).

*Approved for 208, 220, 240, 277 volt operation, refer to wattage adjustment tables for output rating (Table 4 Page 28).

Controls and thermostats should always be used with King heating cable systems.

SR ACCESSORIES Refer to page 36 for SR Accessories

MODEL	UPC	DESCRIPTION	WEIGHT
SRK00	40462	Hard wired power connection kit, includes end seal	0.3 lbs.
SRK02	40461	Connection kit, includes end seal	0.3 lbs.
SRK03	40464	Pipe trace tape (66 ft) and 10 labels per pack	0.1 lbs.
SRK04	61713	2.5" x 50 yards 2 Mil Foil tape	1.0 lbs.
SRK08	40466	Plug in 120V connection kit with GFEP device, includes end seal	1.0 lbs.
SRK10	40468	Weatherproof splice/tee kit, includes end seal	0.2 lbs.
SRK12	40470	End seal kit (2 per package)	0.1 lbs.
SRK14	40473	3M VHB double sided acrylic foam pads (25 per package)	0.1 lbs.
SRK15	40476	Downspout hanger and cable ties	0.3 lbs.
SRK17	40477	11 & 13mm Gel end seal	0.1 lbs.

CT Self-Regulating Pipe Trace Cable

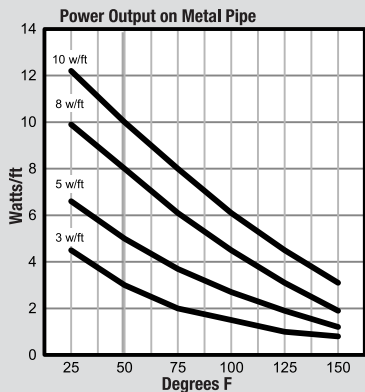

1,000 ft. Reel

Model Code:

SR	12	3	-250	CT
A	B	C	D	E

A: Self Regulating Cable
B: 12 - 120V
24 - 240V
C: Watts per foot
D: Linear Length in feet
E: FluoroPolymer Jacket

Hazardous Locations

Class I, Div. 2, Groups A,B,C,D
 Class II, Div. 2, Groups E,F,G
 Class III



Zone Approvals

T5 or T6

CT self-regulating heating cables are designed for industrial and commercial freeze protection and process-temperature maintenance applications. CT cables maintain process temperatures up to 150°F (65°C) and can withstand intermittent exposure to temperatures up to 185°F (85°C). The heating cables are configured for use in nonhazardous and hazardous locations, including areas where corrosives may be present.

CT Self-Regulating Heating Cable Features

- For both hazardous and non-hazardous locations
- Stops pipe and valve freeze down to -40F
- Cable will not overheat or burn out when overlapped
- Suitable for use on metal and plastic pipes
- 10 year warranty

AVAILABLE LENGTHS

	VOLTS	PIPE RATING** WATTS/FT.	100 FT. LENGTH MODEL / UPC	250 FT. LENGTH MODEL / UPC	500 FT. LENGTH MODEL / UPC	1000 FT. LENGTH MODEL / UPC	WEIGHT/FT.
120V	120	3	SR123-100-CT / 40522	SR123-250-CT / 40523	SR123-500-CT / 40538	SR123-1000-CT / 40375	0.080 LBS./FT.
	120	5	SR125-100-CT / 40524	SR125-250-CT / 40525	SR125-500-CT / 48744	SR125-1000-CT / 40377	0.080 LBS./FT.
	120	8	SR128-100-CT / 40526	SR128-250-CT / 40527	SR128-500-CT / 48745	SR128-1000-CT / 40379	0.080 LBS./FT.
	120	10	SR1210-100-CT / 40528	SR1210-250-CT / 40529	SR1210-500-CT / 48742	SR1210-1000-CT / 40428	0.080 LBS./FT.
240V	240*	3	SR243-100-CT / 40530	SR243-250-CT / 40531	SR243-500-CT / 48747	SR243-1000-CT / 40376	0.080 LBS./FT.
	240*	5	SR245-100-CT / 40532	SR245-250-CT / 40533	SR245-500-CT / 48748	SR245-1000-CT / 40378	0.080 LBS./FT.
	240*	8	SR248-100-CT / 40534	SR248-250-CT / 40535	SR248-500-CT / 48749	SR248-1000-CT / 40380	0.080 LBS./FT.
	240*	10	SR2410-100-CT / 40536	SR2410-250-CT / 40537	SR2410-500-CT / 48746	SR2410-1000-CT / 40382	0.080 LBS./FT.

**Wattage rating for pipe freeze protection application is determined at 50°F (10°C).

*Approved for 208, 220, 240, 277 volt operation, refer to wattage adjustment tables for output rating (Table 4 Page 28).

Controls and thermostats should always be used with King heating cable systems.

CT ACCESSORIES FOR NON HAZARDOUS APPLICATIONS

SRK00	Hard wired power connection kit, includes end seal
SRK03	Pipe trace tape (66 ft) and 10 labels per pack
SRK04	2.5" x 50 yards 2 Mil foil tape
SRK08	Plug in 120V connection kit with GFEP device, includes end seal
SRK10	Weatherproof splice/tee kit, includes end seal
SRK12	End seal kit (2 per package)
SRK17	11 & 13mm Gel end seal

CT ACCESSORIES FOR HAZARDOUS APPLICATIONS

CT-9001	CT octagon & square power connection box
CT-9002	CT square box
CT-9003	CT splice connection
CT-9004	CT tee connection
CT-9005	CT end seal



CT-9001



CT-9002



CT-9003



CT-9004



CT-9005



Roof/Gutter De-Icing



Roof/Gutter De-icing Systems

King's Roof/Gutter De-icing systems helps prevent snow and ice build-up on roofs and gutters. Whether installed on a shake, shingle or metal roof, the SRP & SR will give you the desired results you are looking for. The system is reliable and will not overheat or burn out if overlapped.

SR Series Self-Regulating Heating Cable is designed for commercial and industrial pipe trace applications. The cable is constructed so that it will not burn out or overheat when overlapped, and can be used on metal and plastic pipes. The cable is available in 100 and 250 ft coils and also 500 and 1,000 ft reels.

SRP Series Self-Regulating Pre-Assembled Heating Cable is designed for a variety of gutter and roof de-icing applications. The cable is constructed so that it will not burn out or overheat when overlapped, and can be used on metallic and nonmetallic downspouts and gutters. The cable is pre-terminated with a 30 inch cold lead and grounded plug

CWR Series is designed to prevent costly roof damage caused by ice dams forming and helps maintain free flowing water through gutters and downspouts to the ground level. Requires no special wiring or assembly. Simply run cable per the instructions for both shingle and metal roofs. Sizes range from 20ft - 240ft to accommodate most roofs. System includes roof clips and spacers.

Shake/Shingle Roof Installation

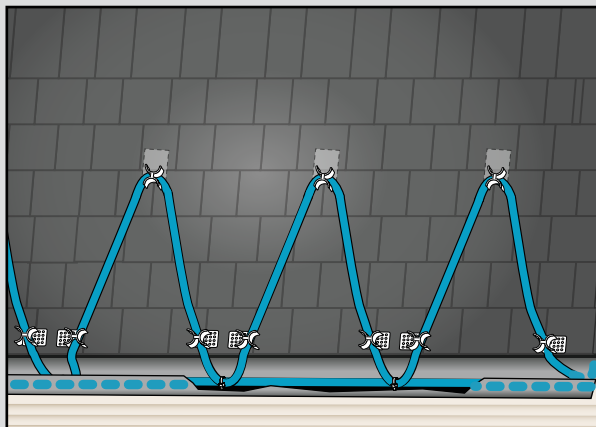

Metal Seam Roof Installation

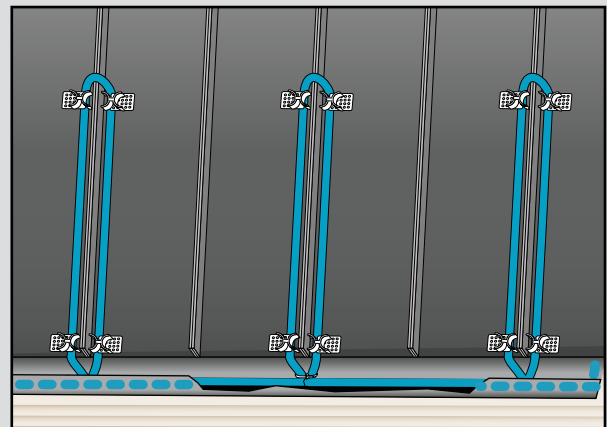

Pre-Assembled Self-Regulating De-Icing Cable

Pre-Assembled



120 Volt - Grounded Plug



Model Code:

SRP 12 6 -6
A B C D

A: Pre-Assembled Self Reg.

B: 12 - 120V

24 - 240V

C: Watts per foot*

D: Linear Length in feet

SRP Series Self-Regulating Pre-Assembled Heating Cable is designed for a variety of roof & gutter de-icing applications.

SRP Self-Regulating Pre-Assembled Heating Cable Features

- Pre-terminated with 30 inch ground plug and end splice
- Suitable for metallic and nonmetallic gutters and downspouts
- 2 year warranty
- Cable will not overheat or burn out when overlapped
- 16 gauge heating cable bus wire



120V

MODEL	UPC	LENGTH	VOLTS	WATTS*
SRP126-6	40400	6 FT.	120	48
SRP126-12	40402	12 FT.	120	96
SRP126-18	40404	18 FT.	120	144
SRP126-24	40406	24 FT.	120	192
SRP126-37	48711	37.5 FT.	120	300
SRP126-50	40408	50 FT.	120	400
SRP126-62	48712	62.5 FT.	120	500
SRP126-75	40410	75 FT.	120	600
SRP126-87	48713	87.5 FT.	120	700
SRP126-100	40412	100 FT.	120	800
SRP126-125	48714	125 FT.	120	1000
SRP126-150	48715	150 FT.	120	1200

*Wattage rating for roof and gutter de-icing application is 8 w/ft determined at 32°F (0°C).



240 Volt - Cold Leads



SRP Series Self-Regulating Pre-Assembled Heating Cable is designed for a variety of roof & gutter de-icing applications.

SRP Self-Regulating Pre-Assembled Heating Cable Features

- Cable will not overheat or burn out when overlapped
- Suitable for use on metal and plastic pipes
- 16 gauge heating cable bus wire
- 2 year warranty



240V

MODEL	UPC	LENGTH	VOLTS	WATTS*
SRP246-6	42373	6 FT.	240	48
SRP246-12	42374	12 FT.	240	96
SRP246-18	42375	18 FT.	240	144
SRP246-24	42376	24 FT.	240	192
SRP246-37	48716	37.5 FT.	240	300
SRP246-50	42377	50 FT.	240	400
SRP246-62	48717	62.5 FT.	240	500
SRP246-75	42378	75 FT.	240	600
SRP246-87	48718	87.5 FT.	240	700
SRP246-100	42379	100 FT.	240	800
SRP246-125	48719	125 FT.	240	1000
SRP246-150	48720	150 FT.	240	1200
SRP246-175	48721	175 FT.	240	1400
SRP246-200	48722	200 FT.	240	1600

*Wattage rating for roof and gutter de-icing application is 8 w/ft determined at 32°F (0°C).

Constant Wattage Roof/Gutter De-Icing Cable



Model Code:

CWR 100 -20
A B C

A: Constant Wattage
B: Watts
C: Linear Length in feet

CWR Series Constant Wattage Roof & Gutter De-icing Cable is designed to prevent ice dams from forming on roof and in gutters.

CWR Constant Wattage Roof & Gutter De-icing Cable Features

- Watertight end seals, guaranteed reliability
- 6 Ft. cold lead with plug
- 5W/Ft. output
- Pre-assembled and ready to install
- Includes roof clips and spacers
- 1 year warranty



Intertek

120V

MODEL	UPC	LENGTH	VOLTS	WATTS (5 W/FT.)	AMPS
CWR100-20	48701	20 FT.	120	100	0.8
CWR150-30	48702	30 FT.	120	150	1.25
CWR300-60	48703	60 FT.	120	300	2.5
CWR400-80	48704	80 FT.	120	400	3.3
CWR500-100	48705	100 FT.	120	500	4.2
CWR600-120	48706	120 FT.	120	600	5.0
CWR800-160	48707	160 FT.	120	800	6.7
CWR1000-200	48708	200 FT.	120	1000	8.3
CWR1200-240	48709	240 FT.	120	1200	10.0

****NOTE: Do not overlap cable.**

CWR Series is designed to prevent costly roof damage caused by ice dams forming and helps maintain free flowing water through gutters and downspouts to the ground level. Requires no special wiring or assembly. Simply run cable per the instructions for both shingle and metal roofs. Sizes range from 20ft - 240ft to accommodate most roofs. System includes roof clips and spacers.

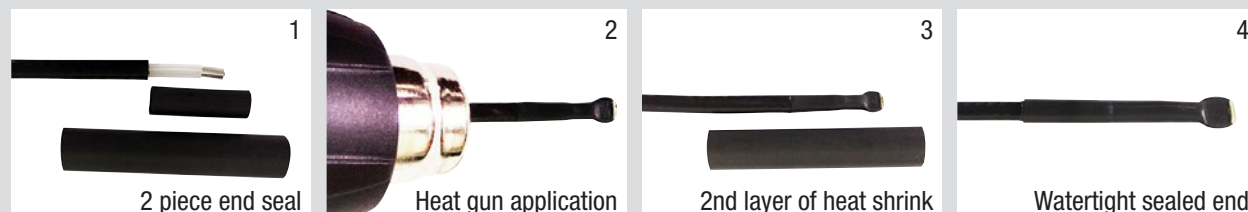

King's CWR Series uses the latest heat shrink technology to secure our end-seals. This guarantees the most consistent, reliable and watertight connection available in the market versus older end-seal technology. Guaranteed reliability.

CWR IceFree™ Controller



CWRK-35



CWR-120 IceFree™

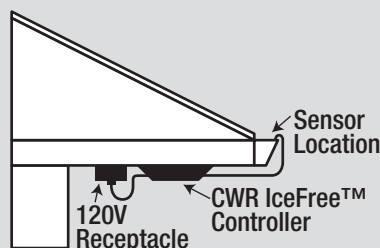

The CWR IceFree™ Controller is designed specifically for use with King's CWR constant wattage roof and gutter De-Icing cable. Designed to sense both temperature and the presence of run-off water, ensuring the heating cable only operates when necessary to prevent ice dams and frozen drains. Both conditions must be met or the system does not run, saving on your energy bill and eliminating waste. The CWR IceFree™ Controller is rated at 10 amps at 120V, requiring one unit per cable. 1200W Max. Use with CWR Cable.

- ABS construction
- Electronic sensor
- 120V, Max. wattage 1200W
- Water resistant enclosure

MODEL	UPC	Item	Description
CWR-120	48710	Snow sensor	CWR IceFree Controller with 6 ft. cord and grounded plug
CWRK-35	48732	Accessory Kit	19 Roof Clips & 16 Spacers

**Controls and thermostats should always be used with King heating systems.

Self-Regulating Roof/Gutter De-Icing Cable



Model Code:

SR 12 3 -250
A B C D

A: Self Regulating Cable

B: 12 - 120V

24 - 240V

C: Watts per foot

D: Linear Length in feet

SR Series Self-Regulating Heating Cable is designed for a variety of industrial and commercial de-icing applications.

SR Self-Regulating Heating Cable Features

- Cable will not overheat or burn out when overlapped
- 2 year warranty
- Suitable for metallic and nonmetallic gutters and downspouts
- Wattage rating is determined at 32°F (0°C).



AVAILABLE LENGTHS

		AVAILABLE LENGTHS				
	DE-ICING RATING**	100 FT. LENGTH	250 FT. LENGTH	500 FT. LENGTH	1000 FT. LENGTH	WEIGHT/FT.
VOLTS	WATTS/FT.	MODEL / UPC	MODEL / UPC	MODEL / UPC	MODEL / UPC	
120V	5	SR123-100 / 40513	SR123-250 / 40414	SR123-500 / 48735	SR123-1000 / 40416	0.080 LBS./FT.
	8	SR125-100 / 40514	SR125-250 / 40418	SR125-500 / 48736	SR125-1000 / 40420	0.080 LBS./FT.
	12.1	SR128-100 / 40515	SR128-250 / 40422	SR128-500 / 48737	SR128-1000 / 40424	0.080 LBS./FT.
	14.8	SR1210-100 / 40516	SR1210-250 / 40426	SR1210-500 / 48733	SR1210-1000 / 40428	0.080 LBS./FT.
240V	5	SR243-100 / 40517	SR243-250 / 40430	SR243-500 / 48739	SR243-1000 / 40432	0.080 LBS./FT.
	8	SR245-100 / 40518	SR245-250 / 40434	SR245-500 / 48740	SR245-1000 / 40436	0.080 LBS./FT.
	12.1	SR248-100 / 40519	SR248-250 / 40438	SR248-500 / 48741	SR248-1000 / 40440	0.080 LBS./FT.
	14.8	SR2410-100 / 40520	SR2410-250 / 40442	SR2410-500 / 48738	SR2410-1000 / 40444	0.080 LBS./FT.

**Wattage rating for roof and gutter de-icing application is determined at 32°F (0°C).

*Approved for 208, 220, 277 volt operation, refer to wattage adjustment tables for output rating (Table 4 Page 28).

Controls and thermostats should always be used with King heating cable systems.

SR ACCESSORIES Refer to page 36 for SR Accessories

MODEL	UPC	DESCRIPTION	WEIGHT
CWRK-35	48732	19 Roof Clips & 16 Spacers	0.09 lbs.
SRK00	40462	Hard wired power connection kit, includes end seal	0.3 lbs.
SRK02	40461	Connection kit, includes end seal	0.3 lbs.
SRK08	40466	Plug in 120V connection kit with GFEP device, includes end seal	1.0 lbs.
SRK10	40468	Weatherproof splice/tee kit, includes end seal	0.2 lbs.
SRK12	40470	End seal kit (2 per package)	0.1 lbs.
SRK13	40472	Roof Clip (25 per package)	0.2 lbs.
SRK14	40473	3M VHB double sided acrylic foam pads (25 per package)	0.1 lbs.
SRK15	40476	Downspout hanger and cable ties	0.3 lbs.
SRK17	40477	11 & 13mm Gel end seal	0.1 lbs.

CT Self-Regulating Roof/Gutter De-Icing Cable

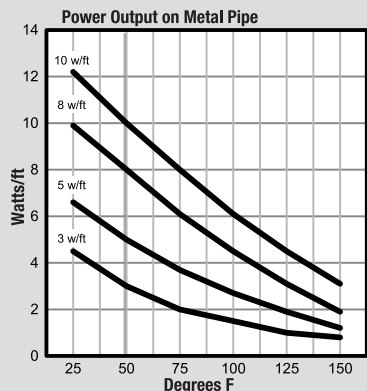

1,000 ft. Reel

Model Code:

SR 12 3 -250 CT
A B C D E

- A: Self Regulating Cable**
- B: 12 - 120V**
24 - 240V
- C: Watts per foot**
- D: Linear Length in feet**
- E: FluoroPolymer Jacket**

Hazardous Locations

Class I, Div. 2, Groups A,B,C,D
 Class II, Div. 2, Groups E,F,G
 Class III



Zone Approvals

T5 or T6

CT self-regulating heating cables are designed for industrial and commercial roof and gutter de-icing applications. The fluoropolymer outer jacket (-CT) provides maximum abrasion, chemical, and mechanical resistance. Configured for use in nonhazardous and hazardous locations, including areas where corrosives may be present.

CT Self-Regulating Heating Cable Features

- For both hazardous and non-hazardous locations
- Cable will not overheat or burn out when overlapped
- Suitable for roofs made from standard roofing materials, including shake, shingle, rubber, tar, wood, metal, and plastic
- Suitable for use on metallic and nonmetallic gutters and downspouts
- Wattage rating is determined at 32°F (0°C)
- 10 year warranty

AVAILABLE LENGTHS

	VOLTS	PIPE RATING** WATTS/FT.	100 FT. LENGTH MODEL / UPC	250 FT. LENGTH MODEL / UPC	500 FT. LENGTH MODEL / UPC	1000 FT. LENGTH MODEL / UPC	WEIGHT/FT.
120V	120	5	SR123-100-CT / 40522	SR123-250-CT / 40523	SR123-500-CT / 40538	SR123-1000-CT / 40375	0.080 LBS./FT.
	120	8	SR125-100-CT / 40524	SR125-250-CT / 40525	SR125-500-CT / 48744	SR125-1000-CT / 40377	0.080 LBS./FT.
	120	12.1	SR128-100-CT / 40526	SR128-250-CT / 40527	SR128-500-CT / 48745	SR128-1000-CT / 40379	0.080 LBS./FT.
	120	14.8	SR1210-100-CT / 40528	SR1210-250-CT / 40529	SR1210-500-CT / 48742	SR1210-1000-CT / 40428	0.080 LBS./FT.
240V	240*	5	SR243-100-CT / 40530	SR243-250-CT / 40531	SR243-500-CT / 48747	SR243-1000-CT / 40376	0.080 LBS./FT.
	240*	8	SR245-100-CT / 40532	SR245-250-CT / 40533	SR245-500-CT / 48748	SR245-1000-CT / 40378	0.080 LBS./FT.
	240*	12.1	SR248-100-CT / 40534	SR248-250-CT / 40535	SR248-500-CT / 48749	SR248-1000-CT / 40380	0.080 LBS./FT.
	240*	14.8	SR2410-100-CT / 40536	SR2410-250-CT / 40537	SR2410-500-CT / 48746	SR2410-1000-CT / 40382	0.080 LBS./FT.

**Wattage rating for roof and gutter de-icing application is 8 w/ft determined at 32°F (0°C).

*Approved for 208, 220, 240, 277 volt operation, refer to wattage adjustment tables for output rating (Table 4 Page 28).

Controls and thermostats should always be used with King heating cable systems.

CT ACCESSORIES FOR HAZARDOUS APPLICATIONS

CT-9001CT	CT octagon & square power connection box
CT-9002CT	CT square box
CT-9003CT	CT splice connection
CT-9004CT	CT tee connection
CT-9005CT	CT end seal



CT-9001



CT-9002



CT-9003



CT-9004



CT-9005

Charts & Tables SRP Pre-assembled Self Regulating Cable



Pipe freeze protection

Cable Construction Table

Outer Jacket	Rugged polyolefin UV jacket
Ground Braid	Tinned copper
Inner Jacket	Flame retardant thermoplastic
Core	Self-regulating semi-conductive core
Bus Wire	16 gauge tinned copper

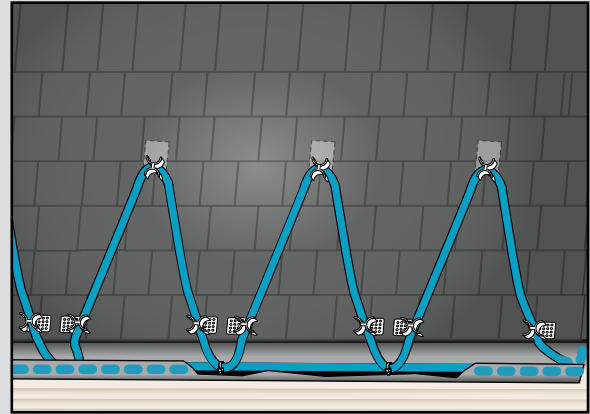
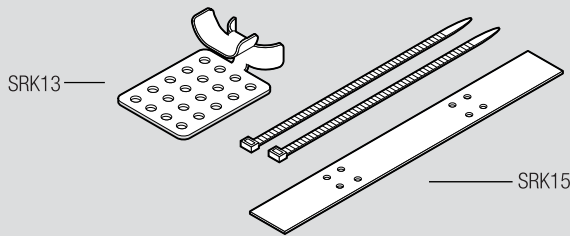

Roof and gutter de-icing (SRK13 Roof Clips)

SRP self-regulating pre-assembled heating cable are designed for a variety of pipe freeze protection and roof & gutter de-icing applications. The heat output (wattage) increases and decreases automatically based on changes in the climate conditions. This unique feature ensures maximum energy efficiency because the cable regulates heat output on its own, increasing energy output only when it is needed to prevent pipe freezing and ice build up on roofs & gutters. No thermostat is required.

SRP Cable Features

- Rated 6 watts/foot at 40° F (5°C) for pipe freeze protection
- Pre-terminated with 30 inch ground plug and end splice
- Suitable for metallic and nonmetallic gutters and downspouts
- 16 gauge heating cable bus wire
- Rated 8 watts/foot at 32°F (0°C) for roof and de-icing
- Suitable for use on metal and plastic pipes
- Cable will not overheat or burnout when overlapped
- 2 year warranty

Kit Contents:

- SRP pre-assembled electric heating cable
- Roof and gutter labels
- Pipe trace labels

SRP Cables and Accessories

120V MODEL	UPC	240V MODEL	UPC	LENGTH	PIPE RATING*	DE-ICING RATING*
SRP126-6	40400	SRP246-6	42373	6 FT.	36 W	48 W
SRP126-12	40402	SRP246-12	42374	12 FT.	72 W	96 W
SRP126-18	40404	SRP246-18	42375	18 FT.	108 W	144 W
SRP126-24	40406	SRP246-24	42376	24 FT.	144 W	192 W
SRP126-37	48711	SRP246-37	48716	37.5 FT.	225 W	300 W
SRP126-50	40408	SRP246-50	42377	50 FT.	300 W	400 W
SRP126-62	48712	SRP246-62	48717	62.5 FT.	375 W	500 W
SRP126-75	40410	SRP246-75	42378	75 FT.	450 W	600 W
SRP126-87	48713	SRP246-87	48718	87.5 FT.	525 W	700 W
SRP126-100	40412	SRP246-100	42379	100 FT.	600 W	800 W
SRP126-125	48714	SRP246-125	48719	125 FT.	750 W	1000 W
SRP126-150	48715	SRP246-150	48720	150 FT.	900 W	1200 W
		SRP246-175	48721	175 FT.	1050 W	1400 W
		SRP246-200	48722	200 FT.	1200 W	1600 W

*Wattage rating for pipe freeze protection application is determined at 40°F (5°C). Wattage rating for roof and gutter de-icing application is determined at 32°F (0°C).

MODEL	UPC	DESCRIPTION
SRK03	40464	Pipe trace tape (66 ft.) and 10 labels per pack
SRK13	40472	Roof clip (25 per pack)
SRK15	40476	Downspout hanger and cable ties

Heating Cable Selection for Pipe Freeze Protection

Pipe	Type	5'	10'	15'	20'	25'	30'	35'	40'	45'	50'	55'	60'	65'	70'	75'	80'	85'	90'	95'	100'	125'	150'	175'	200'
1/2"	M	A	B	C	D	E	E	E	F	F	F	G	G	H	H	H	I	I	J	J	J	K	L	M	N
	P	A	B	C	D	E	E	F	F	F	G	G	H	H	H	I	I	J	J	J	K	L	M	N	-
1"	M	A	B	C	D	E	E	E	F	F	F	G	G	H	H	H	I	I	J	J	J	K	L	M	N
	P	B	B	C	D	E	E	F	F	F	G	G	H	H	H	I	I	J	J	J	K	L	M	N	-
1 1/2"	M	A	B	C	D	E	E	E	F	F	F	G	G	H	H	H	I	I	J	J	J	K	L	M	N
	P	B	C	D	E	E	F	F	F	G	G	H	H	H	I	I	J	J	J	K	K	M	N	-	-
2"	M	A	B	C	D	E	E	E	F	F	G	G	H	H	H	I	I	J	J	J	K	L	M	N	-
	P	B	C	E	E	F	G	H	H	I	J	J	K	K	L	L	L	M	M	M	N	-	-	-	-
2 1/2"	M	A	C	C	D	E	F	F	F	G	G	H	H	I	I	J	J	K	K	K	K	L	N	-	-
	P	B	D	E	F	G	H	I	J	K	K	L	L	M	M	N	N	-	-	-	-	-	-	-	-

A	B	C	D	E	F	G	H	I	J
SRP126-6 SRP246-6	SRP126-12 SRP246-12	SRP126-18 SRP246-18	SRP126-24 SRP246-24	SRP126-37.5 SRP246-37.5	SRP126-50 SRP246-50	SRP126-62.5 SRP246-62.5	SRP126-75 SRP246-75	SRP126-87.5 SRP246-87.5	SRP126-100 SRP246-100
						K	L	M	N
						SRP126-125 SRP246-125	SRP126-150 SRP246-150	SRP246-175	SRP246-200

M = Metal Pipe / P = Plastic Pipe

Add 1 foot to the cable length for each valve or spigot.

Chart is based on the lowest outside temperature of 0°F (-18°C)

with a minimum of 1/2" thick fiberglass insulation. Use 1" insulation for protection down to -20°F (-29°C).



Selecting the Required Heating Cable Length for Roof and Gutter De-icing

How to Calculate the proper Heating Cable Length:

Use the formula below to determine the amount of heating cable required.

Total heating cable length = A+B+C+D

A (Roof edge) x (heating cable multiplier)

B (Roof edge x 0.5)

C (Total gutter length)

D (Total downspout length + 1 ft.)

=Total heating cable length required.

Example: Standard Roof

1. Roof edge = 14 ft.
2. Eave overhang = 1 ft. (Refer to cable multiplier table)
3. Gutter = 14 ft.
4. Downspout = 12 ft.

Heating Cable Required:

Roof edge: 14 ft. x 2.8 (Multiplier from table) = 39.2 ft.
 Roof extension*: 14 ft. x 0.5 = 7.0 ft.
 Roof gutter: 14 ft. = 14.0 ft.
 Downspout: 12 ft. + 1 ft. = 13.0 ft.
 Total heating cable length required: = 73.2 ft.

Solution for Example = SRP126-75

*Roof extension is the length of cable required to prevent ice dams between the roof edge and the gutter. When there are no gutters present it forms a drip loop to prevent ice dams at the roof edge.

Heating Cable Multiplier Table

Eave Overhang	Standard Roof	Metal Roof (18" Seam)	Metal Roof (24" Seam)
None	2.0	2.5	2.0
12"	2.8	2.8	2.4
24"	3.8	3.6	2.9
36"	4.8	4.3	3.6

Use the number in the table and multiply it by the length of the roof edge.

Calculations for Gutters, Downspouts and Valleys:

1. For standard non-metal roofs, add 1 foot of heating cable for each foot of gutter.
2. Add 1 foot of heating cable per foot of downspout.
3. If the downspout is in the middle of the run, loop the cable down and back up. Double the length of the downspout for determining the length of cable to install.
4. For valleys, run the heating cable two thirds of the way up and down the valley. Add this additional length to the overall cable.
5. For gutters 6 inches wide use two cable runs.

Charts & Tables SR Self Regulating Cable

For Pipe Freeze Protection and Roof & Gutter De-Icing



Description:

King SR Self-regulation cable is designed for a variety of industrial and commercial pipe trace applications including hazardous and non hazardous environments. The standard polyolefin jacket is water resistant and resistant to inorganic chemicals. With the optional (-CT) jacket, the cable is resistant to organic chemicals and corrosive environments.

The cable will regulate its power output (watt/ft.) automatically in response to changes in the surrounding temperature. Parallel construction makes it easier to install than zone or series types of cable since it can be cut to length at any point and terminated on site. The self-regulating feature allows the cable to be overlapped without overheating or burning out the cable.

SR is available in 3, 5, 8 and 10 watts per foot at 120, 240 volts. SR heating cable carries a 2 year warranty.

Cable Construction Table

Outer Jacket	Rugged polyolefin UV jacket
Outer Jacket (-CT)*	Fluoropolymer jacket
Ground Braid	Tinned copper
Inner Jacket	Flame retardent thermoplastic
Core	Self-regulating semi-conductive core
Bus Wire	16 gauge tinned copper

*Add -CT to the end of the model number for Fluoropolymer jacket.

Technical Data Table

Maximum operating temperature	150°F (65°C)
Maximum exposure temperature	185°F (85°C)
Minimum installation temperature	-40°F (-40°C)
Minimum bending radius	1" (24mm)
Dimensions	0.496" x 0.236" (12.6mm x 6mm)
Service Voltage	110V-120V, 208V-277V
Wattage rating temperature	50°F (10°C)
Hazardous Location Rating (-CT Outer Jacket only)	Class I, Div. 2 Class II, Div. 2 Class III

Power Output on Metal Pipe

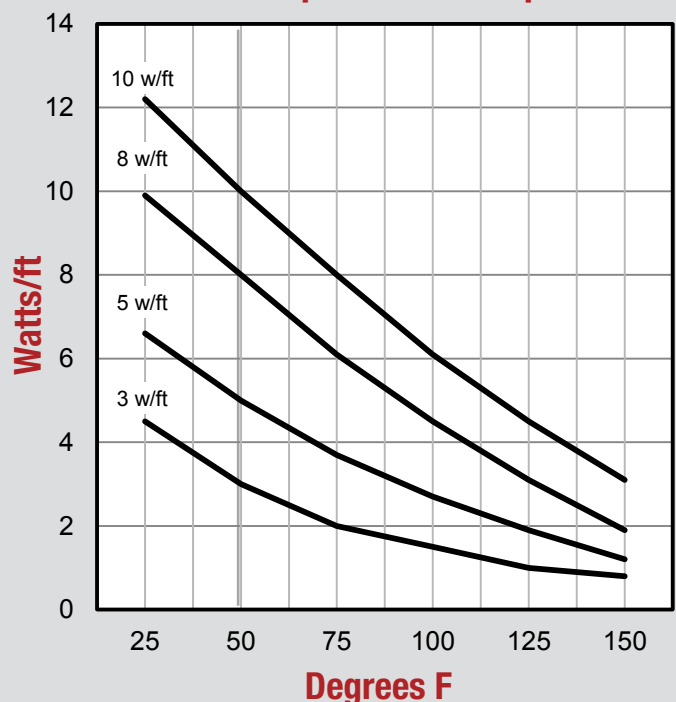

Charts & Tables SR Self Regulating Cable Pipe Freeze Protection

Heating Cable Selection for Pipe Freeze Protection

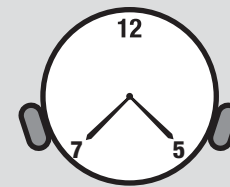
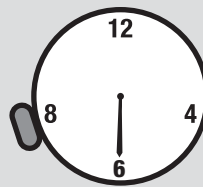
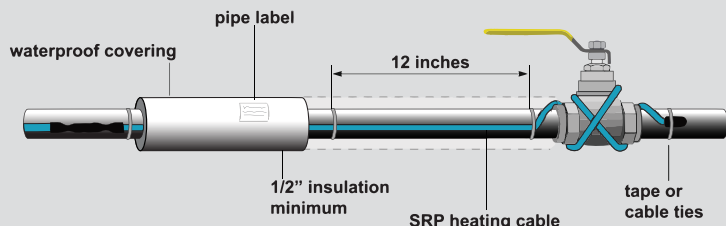

Single Cable Location

Double Cable Location

For a single cable, run it straight along the bottom of the pipe in the 4 or 8 o'clock position. If two cables are required, attach them at the 4 and 8 o'clock positions as shown in the figure above.

Use Table 1 to select the cable size for metal pipes and use Table 2 for plastic pipes. Read across the table to find the pipe size, then drop down to the row corresponding to the design air temperature and the thickness of the insulation that will be used. The cell that intersects will give the power (watts/ft.) of the heating cable required, it may also have a (2) in the cell which means 2 cables are required.

Table 1 - SR Cable Selection for Metal Pipes (w/ft.)¹

Lowest Air Temp.	Insulation Thickness	1/2"	3/4"	1"	1 1/4"	1 1/2"	2"	2 1/2"	3"	4"	6"	8"
0°F (-18°C)	1/2"	3	3	3	3	5	5	5	5	8	8	10
	1"	3	3	3	3	3	3	3	5	5	8	8
	1-1/2"	3	3	3	3	3	3	3	3	5	5	5
	2"	3	3	3	3	3	3	3	3	3	5	5
-20°F (-29°C)	1/2"	3	5	5	5	5	5	8	8	10	10	*
	1"	3	3	3	3	3	5	5	5	8	8	10
	1-1/2"	3	3	3	3	3	3	3	5	5	8	8
-40°F (-40°C)	2"	3	3	3	3	3	3	3	3	5	5	8
	1/2"	5	5	5	5	8	8	10	(2) 8	(2) 8	(2) 10	*
	1"	3	3	3	5	5	5	8	8	8	10	(2) 8
	1-1/2"	3	3	3	3	3	5	5	5	8	8	10
-40°F (-40°C)	2"	3	3	3	3	3	3	3	5	5	8	8
	3"	3	3	3	3	3	3	3	3	3	5	5

Table 2 - SR Cable Selection for Plastic Pipes (w/ft.)¹

Lowest Air Temp.	Insulation Thickness	1/2"	3/4"	1"	1 1/4"	1 1/2"	2"	2 1/2"	3"	4"	6"	8"
0°F (-18°C)	1/2"	3	5	5	5	8	8	8	10	(2) 8	(2) 10	*
	1"	3	3	3	5	5	5	5	5	5	8	8
	1-1/2"	3	3	3	3	3	3	5	8	8	8	10
	2"	3	3	3	3	3	3	3	5	5	8	8
-20°F (-29°C)	1/2"	5	5	8	8	10	10	(2) 8	(2) 8	(2) 10	*	*
	1"	3	3	5	5	5	8	8	8	10	(2) 8	(2) 10
	1-1/2"	5	5	5	5	5	5	5	8	8	10	(2) 8
-40°F (-40°C)	2"	3	3	3	3	3	5	5	5	8	8	10
	1/2"	8	8	8	8	10	10	(2) 8	(2) 10	*	*	*
	1"	5	5	5	8	8	8	10	10	(2) 8	*	*
	1-1/2"	5	5	5	5	5	8	8	8	10	(2) 8	(2) 10
-40°F (-40°C)	2"	5	5	5	5	5	5	5	8	8	10	(2) 8
	3"	3	3	5	5	5	5	5	5	5	8	10

1. Tables are based on using fiberglass insulation or equivalent while maintaining a 40°F (4°C) pipe temperature with a 10% safety factor and 20 mph wind speed.

*Contact King for proper cable selection.

Heating Cable Selection for Roof/Gutter De-Icing

Calculation For Heating Cable Length

Total heating cable length = A+B+C+D+E+F+G

A (Roof edge) x (heating cable multiplier)

B (Roof edge x 0.5)

C (Total gutter length)

D (Total downspout length + 1 ft.)

E (1 ft. for each power connection)

F (2 ft. for each splice)

G (3 ft. for each tee connection)

=Total heating cable length required.

Example:

1. Roof edge = 48 ft.
2. Eave overhang = 1 ft. (Refer to cable table 6)
3. Gutter = 48 ft.
4. Downspout = 22 ft.
5. Power connection = 2 each
6. Splice = 3 each

Heating Cable Required:

A Roof edge:	48 ft. x 2.8 (From table 6)	= 134.4 ft.
B Roof extension*:	48 ft. x 0.5	= 24.0 ft.
C Roof gutter:	48 ft.	= 48.0 ft.
D Downspout:	22 ft. + 1 ft.	= 23.0 ft.
E Power Connection:	2 x 1 ft.	= 2.0 ft.
F Splice Connection:	3 x 2 ft.	= 6.0 ft.
G Tee Connection:	0 x 3 ft.	= 0 ft.
Total heating cable length required:		= 237.4 ft.

*Roof extension is the length of cable required to prevent ice dams between the roof edge and the gutter. When there are no gutters present it forms a drip loop to prevent ice dams at the roof edge.

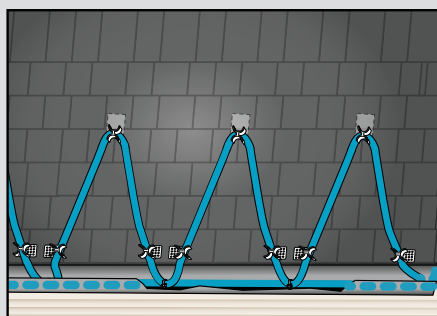

Table 7 - Tracing Heights for Shake/Shingle Roof

Eave Overhang	Tracing Width	Tracing Height	Cable/Roof Edge
None	24"	18"	2.0 ft.
12"	24"	18"	2.8 ft.
24"	24"	30"	3.8 ft.
36"	24"	42"	4.8 ft.

The last column gives the amount of cable required per foot of roof edge for standard shake and shingle roof (table 7) or a metal seam roof (table 8).

Table 6 - Heating Cable Multiplier

Eave Overhang	Standard Roof	Metal Roof 18" Seam	Metal Roof 24" Seam
None	2.0	2.5	2.0
12"	2.8	2.8	2.4
24"	3.8	3.6	2.4
36"	4.8	4.3	3.6

Use the number in the table and multiply it by the length of the roof

Calculations for Gutters, Downspout and Valley

1. For standard non-metal roofs, add 1 foot of heating cable for each foot of gutter.
2. Add 1 foot of heating cable per foot of downspout.
3. If the downspout is in the middle of the run, loop the cable down and back up. Double the length of the downspout for determining the length of the cable to install.
4. For valleys, run the heating cable two thirds of the way up and down the valley. Add this additional length to the overall cable.
5. For gutters 6 inches wide use two cable runs.

Design Notes

1. In-line splices and tee splices should be avoided where possible.
2. Heating cable in downspouts should be looped and extend below the frost line if tied into a drainage system.
3. End terminations should not be located in an area where moisture is present. End terminations should not be located at the lowest point of downspouts.
4. For roof drains leading into a heated area, a loop of heating cable should be installed to a depth of 3 ft.

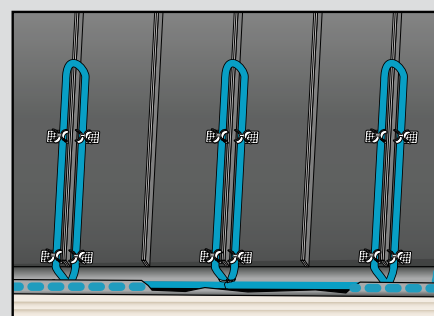

Table 8 - Tracing Heights for Metal Seam Roof

Eave Overhang	Tracing Width	Tracing Height	Cable/Roof Edge
None	18"	18"	2.5 ft.
12"	18"	24"	2.8 ft.
24"	18"	36"	3.6 ft.
36"	18"	48"	4.3 ft.
None	24"	18"	2.0 ft.
12"	24"	24"	2.4 ft.
24"	24"	36"	2.9 ft.
36"	24"	48"	3.6 ft.

Charts & Tables SR Self Regulating Cable Roof/Gutter De-Icing

Table 9 - Circuit Breaker Protection for De-icing

Cable	Volts	Start up Temp.	15 Amp (ft.)	20 Amp (ft.)	30 Amp (ft.)	40 Amp (ft.)
SR123	120V	32°F (0°C)	273	273	273	273
		20°F (-7°C)	254	268	273	273
		0°F (-18°C)	213	255	273	273
		-20°F (-29°C)	182	248	273	273
SR243	240V	32°F (0°C)	547	547	547	547
		20°F (-7°C)	501	547	547	547
		0°F (-18°C)	426	547	547	547
		-20°F (-29°C)	368	492	547	547
SR125	120V	32°F (0°C)	188	216	216	216
		20°F (-7°C)	166	216	216	216
		0°F (-18°C)	144	193	216	216
		-20°F (-29°C)	127	173	216	216
SR245	240V	32°F (0°C)	381	432	432	432
		20°F (-7°C)	331	432	432	432
		0°F (-18°C)	292	387	432	432
		-20°F (-29°C)	258	347	432	432
SR128	120V	32°F (0°C)	126	168	171	171
		20°F (-7°C)	118	157	171	171
		0°F (-18°C)	103	136	171	171
		-20°F (-29°C)	92	123	168	171
SR248	240V	32°F (0°C)	257	342	347	347
		20°F (-7°C)	235	311	347	347
		0°F (-18°C)	204	268	347	347
		-20°F (-29°C)	184	244	347	347
SR1210	120V	32°F (0°C)	102	143	152	152
		20°F (-7°C)	97	126	152	152
		0°F (-18°C)	88	117	152	152
		-20°F (-29°C)	76	104	152	152
SR2410	240V	32°F (0°C)	172	226	312	312
		20°F (-7°C)	159	215	312	312
		0°F (-18°C)	150	197	298	312
		-20°F (-29°C)	138	182	273	312

Technical Data Notes:

1. The maximum single cable run is the longest length of heating cable before there is a significant voltage drop which will lower the wattage rating of the cable.
2. The circuit breaker sizes in Table 9 are per the National Electric Code (NEC).

Table 10 - Technical Data Ratings

Technical Data Table	
Maximum operating temp.	150°F (65°C)
Maximum exposure temp.	185°F (85°C)
Minimum installation temp.	0°F (-18°C)
Minimum bending radius	1" (24mm)
Dimensions	0.496" x 0.236" (12.6mm x 6mm)
Service voltage	110-120V, 208V-277V

Table 11 - Maximum Single Run Length

Model	Volts	Output at 32°F (0°C)	Maximum Single Run Length
SR123	120V	5.0 w/ft.	273 ft. (83M)
	208V	4.1 w/ft.	530 ft. (129M)
SR243	240V	5.0 w/ft.	547 ft. (161M)
	277V	5.9 w/ft.	590 ft. (180M)
SR125	120V	8.0 w/ft.	216 ft. (66M)
	208V	7.1 w/ft.	397 ft. (121M)
SR245	240V	8.0 w/ft.	432 ft. (132M)
	277V	9.0 w/ft.	466 ft. (142M)
SR128	120V	12.1 w/ft.	171 ft. (52M)
	208V	11.4 w/ft.	312 ft. (95M)
SR248	240V	12.1 w/ft.	347 ft. (106M)
	277V	13.0 w/ft.	385 ft. (117M)
SR1210	120V	14.8 w/ft.	152 ft. (46M)
	208V	14.2 w/ft.	274 ft. (83M)
SR2410	240V	14.8 w/ft.	312 ft. (95M)
	277V	15.8 w/ft.	346 ft. (106M)

Table 12 - Circuit Length Adjustments

Model	208V	277V
SR243	0.97	1.08
SR245	0.92	1.08
SR248	0.90	1.11
SR2410	0.88	1.11

Circuit length adjustments for 240V cables operated 208V and 277V are noted in Table 12

3. The NEC requires ground-fault equipment protection (GFEP) for fixed outdoor de-icing equipment. All electrical connections should be made by a licensed electrician.

SnowFree™ Snow Melt System

SnowFree™ System



SFC2 SnowFree™ Controller Snow Melt System Kit with Remote Control 2 Zone/24 Amp per Zone



SFC2
2 Zone Controller 24A/2P, 120-240VAC

PYROSB
Mounting Bracket

SFIR
Remote IR Control

Optional: SFMC
Manual Controller

SnowFree™ Controller Snow Melt System with Remote Control

The SFC2 SnowFree System is the ultimate “All in One” Snow Sensor & Controller for light commercial and residential use. A “Plug and Play” controlled for frost protection, ice and snow melt applications. When receiving a signal from the built-in snow sensor, it activates the contactors energizing the heating elements. Based on the configuration and settings, the two outputs to the two zones are activated together or in staggering mode. The outdoor temperature set-point as well as the ambient lower limit temperature can be easily set by the remote control. The Technician Settings mode allows the installer or technician to adjust the parameters for customized installations using the remote control. The adjustable Hold-On (Time delay) is adjustable in the range of 0 up to 48 hours. Installing the system is a quick and easy task. Apart of mounting the metal box to the wall, the installer needs only to connect the line in and line out wires in the marked terminals and the system is ready to work.

- Snow sensor & controller for light commercial and residential use
- Sequencing option between the zones-allowing larger snow melting area with less available power on site
- User friendly programming and setting adjustment using large LCD display remote control
- 1 or 2 zones activation (24A/2P each 120-240 VAC)
- Optional indoor manual control interface—SFMC receiver
- Energy efficient algorithm
- Manual and automatic modes. Selected by physical switch or using the remote control
- Technician testing / commissioning mode for easy and fast system test all year long (even during summer or at high temp)
- Adjustable splitting time between the zones with multi configurations between zones
- Adjustable Hold-ON-OFF delay and manual ON
- Adjustable upper and lower limit temperature
- Adjustable set points

MODEL	UPC	Item	Description
SFC2-KIT	42403	SnowFree System	SFC2 SnowFree Controller with sensor, SFIR SnowFree IR remote, PYROSB Mounting bracket
SFMC (Optional)	42406	Indoor Manual Controller	Wall mounted IR receiver with indication LED's and push button with soft on control cable

**Controls and thermostats should always be used with King heating systems.

PYRO Snow Melt/De-Icing System

PYRO Snow Melt/De-Icing System



PYROBOX5



PYROBOX3 & 3C



PYROULS



PYROSENSE

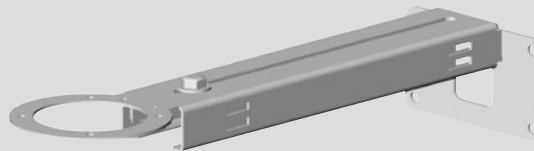

PYROSB



PYROCON12

PYRO De-Icing System

The unique staggering feature of the PYRO control melts snow & ice over larger areas, without the need to upgrade the power supply on site. Use a high demand heating system on a limited power supply source by controlling up to 5 different zones. The modular design allows customers to choose the right configuration for the specific property needs.

Enables use of high demand heating system on a limited power supply source. Modular: Up to 5 circuits/contactors. Up to 600V & 600A

Sequence of zoning 1/2/3/4/ + auxiliary (such as gutter sensor), Suitable for parallel, star & triangle connection. North American consideration operating algorithm.

- User friendly programming and adjusting
- Adjustable cycle time
- Adjustable delay (Hold on Time)
- Adjustable on and off
- Adjustable trip setting
- Non obtrusive adjustable snow sensor
- Integrated Fault Detector. GFCI non class A
- Logical setting for installer / set up & service
- Surface Upper limit adjustable Temperature Sensor
- Integrated option for Universal gutter de-icing sensor
- Programmable & precise snow and ice sensor
- Suitable for electrical & hydronic de-icing installations

MODEL	UPC	Item	Description
PYROBOX3	42329	Power Box 3	4 Zone Controller, 4-30A/2P Contactors, 1-Phase, 277V Max
PYROBOX3C	42328	Power Box 3C	2 Zone Controller, 2-50A/3P Contactors, 3-Phase, 600V Max +1 Zone Aux Controller, 1-30A/2P Contactor, 1-Phase, 277V Max
PYROBOX5	42327	Power Box 5	4 Zone Controller, 4-50A/3P Contactors, 3-Phase, 600V Max +1 Zone Aux Controller, 1-30A/2P Contactor, 1-Phase, 277V Max
PYROSENSE	42323	Snow sensor	Outdoor Snow Sensor
PYROULS	42325	Upper Limit Sensor	Upper Limit Temperature Sensor
PYROCON12	42322	Main Controller	Controller and User Interface panel
PYROSB	42326	Mounting Bracket	Wall mounting adjustable rust free holding bar
PYROSENSE 2/3/4	42324	Snow/Ice Sensor with Numerical Address	Option for Installations Where More Than One Snow Sensor Needed

PYROBOX units are complete with PYROCON12 controller and PYROULS. Order PYROSENSE and PYROSB separately.

**Controls and thermostats should always be used with King heating systems.

PYRO Snow Melt/De-Icing System

PYRO Snow Melt/De-Icing System



PYROBOX5 PYROBOX3 & 3C

The PYROBOX3/3C/5 power boxes together with the PYROCON12 controller and interface panel, offer smart and easy control over the PYRO snow & ice melting system. It can operate up to 4 snow melting zones and one auxillary zone, with selectable sequencing method. Typical applications include driveways, sidewalks, loading docks, stairs, pavement and gutters. The back-lit LCD screen provides full interface and information of the system status. The use of several zones staggering allow covering larger area for snow melting with a limited available electrical power.

The PYROCON12 offers various operating and programming options such as:

- Switchable temperature scales (°F or °C)
- Both automatic and manual modes
- Adjustable heaters cycle and splitting times
- Adjustable heaters hold on, off & delay
- Optional auxiliary control by 3rd party snow sensor (e.g. Gutter sensor)
- Adjustable lower ambient temperature limit to stop heaters (lockout)
- Energy saving upper temperature limit
- Adjustable snow sensor sensitivity (%Rh)
- Commissioning/Test mode

PYRO-X General System Layout With PYROBOX3/3C/5

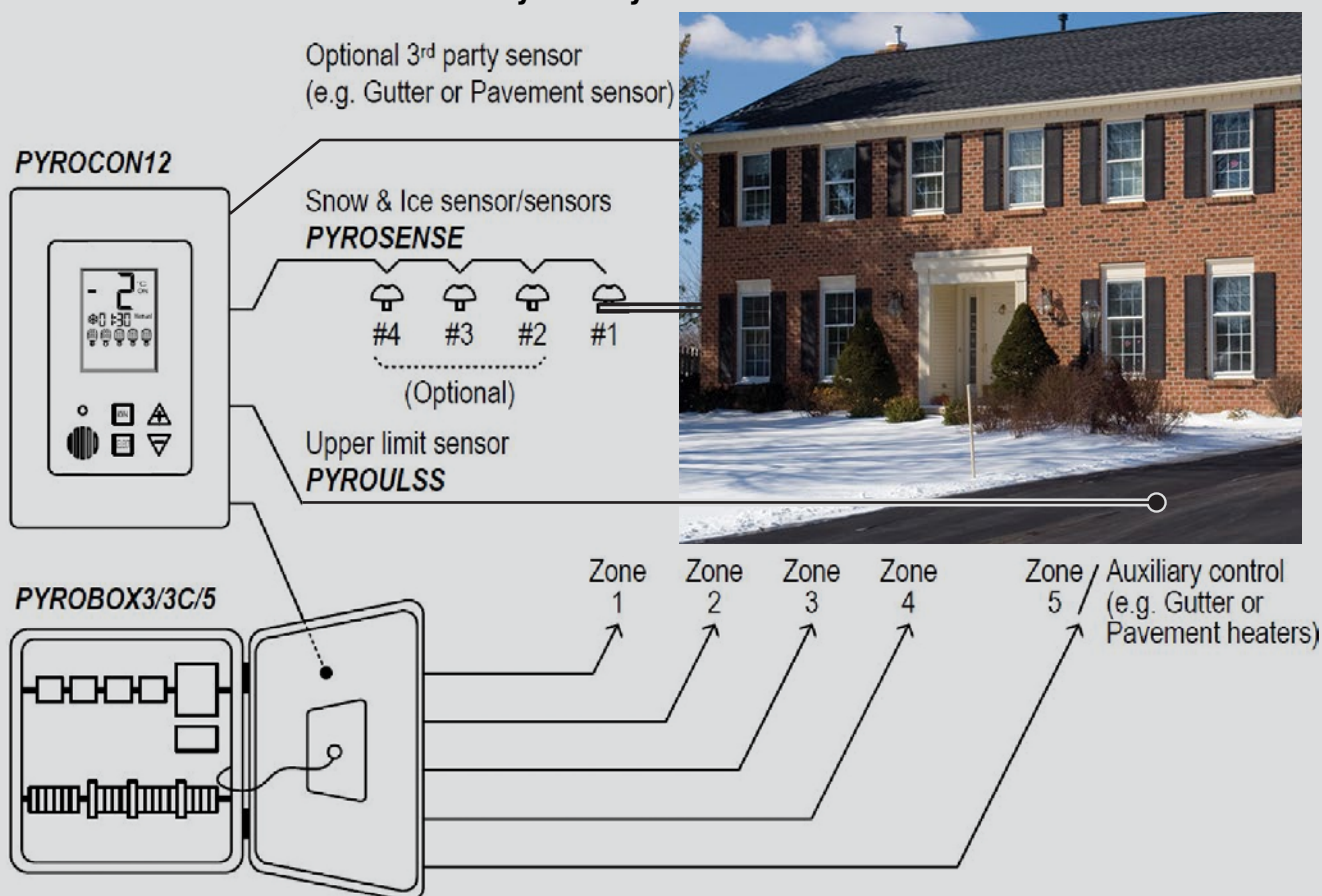

PYRO Freeze Protection Controller

PYRO FPC Freeze Protection Controller



FPC-02-120



PYRO FPC Freeze Protection Controller

Freeze Protection Controller and a Power panel for heat tracing, ice and snow melt applications.

When the temperature drops below the pre-defined, adjustable set-points, the contactor is activated energizing the heating elements. The Technician Settings mode enables an installer, or a technician to adjust the parameters for customized installations using the electronic controller installed in the front panel.

- Up to 30A & 120/240V outputs to the heaters
- Hold-On (Time delay) adjustable range of up to 99 hours
- Temperature input from the provided temperature sensor (10 m. / 30 feet long) and also from a 3rd party aquastat
- Integrated electronic controller with backlit LCD display
- Integral 30mA GFEP allows manual reset from the front panel
- Adjustable Set-points, Hold ON/OFF Time delay and manual ON duration
- Manual and Automatic modes, selected by a button
- Testing/commissioning mode for easy and fast system test, all year long (even during summer or at high temperature condition)
- Multiple sensors input-optional
- ETL listed

MODEL	UPC	Item	Description
FPC-02-120	19112	Pyro FPC Freeze Protection Controller	Freeze Protection Controller 120V, 30A, w/GFEP
FPC-02-240	19113	Pyro FPC Freeze Protection Controller	Freeze Protection Controller 240V, 30A, w/GFEP
FPC-02-120-MDB	19114	Pyro FPC Freeze Protection Controller	Freeze Protection Controller 120V, 30A, w/GFEP & MODBUS
FPC-02-240-MDB	19115	Pyro FPC Freeze Protection Controller	Freeze Protection Controller 240V, 30A, w/GFEP & MODBUS

**Controls and thermostats should always be used with King heating systems.



PYRO Pipe Trace System



**Innovative Zone Based Control System For Pipe Trace Heating Cable.
The Ultimate Controller For Industrial, Commercial and Residential.**



PYROBOX5

PYROBOX3 & 3C



PYROULS



PYROCON12 TRACE

PYRO Pipe Trace System

The unique staggering feature of the PYRO TRACE control keeps pipes from freezing, without the need to upgrade the power supply on site. Use a high demand heating system on a limited power supply by controlling up to 5 different zones. The modular design allows customers to choose the right configuration for the specific property needs.

Enables use of high demand heating system on a limited power supply source. Modular: Up to 5 circuits/contactors. Up to 600V & 600A Sequence of zoning 1/2/3/4/ + auxiliary (such as gutter sensor). Suitable for parallel, star & triangle connection. North American consideration operating algorithm.

- Adjustable temperature sensor
- User friendly programming and adjusting
- Adjustable cycle time between zones
- Adjustable delay (Hold on Time)
- Adjustable on and off
- Logical setting for installer / set up & service
- Second input for temperature switch
- Integrated Fault Detector. GFCI non class A
- Adjustable trip setting
- Non obtrusive adjustable snow sensor
- Electrical and Hydronic freezing applications
- Manual mode

MODEL	UPC	Item	Description
PYROBOX3 TRACE	42388	Power Box 3 Trace	4 Zone Controller, 4-30A/2P Contactors, 1-Phase, 300V Max
PYROBOX3C TRACE	42387	Power Box 3C Trace	2 Zone Controller, 2-50A/3P Contactors, 3-Phase, 600V Max +1 Zone Aux Controller, 1-30A/2P Contactor, 1-Phase, 300V Max
PYROBOX5 TRACE	42386	Power Box 5 Trace	4 Zone Controller, 4-50A/3P Contactors, 3-Phase, 600V Max +1 Zone Aux Controller, 1-30A/2P Contactor, 1-Phase, 300V Max
PYROULS	42325	Upper Limit Sensor	Upper Limit Temperature Sensor
PYROCON12 TRACE	42380	Main Controller	Controller and User Interface panel

PYROBOX units are complete with PYROCON12 TRACE controller and PYROULS.
**Controls and thermostats should always be used with King heating systems.

SR/SRP Accessories



SRK00 Hard Wired Power Connection Kit

Contains labels, pipe mounting bracket, box connector, wire nuts and heat shrink tubing to make electrical supply connection to a metal junction box. Includes one end seal.



SRK02 Connection Kit

Contains heat shrink tubing and woven braid. Also includes one end seal.



SRK10 Splice and Tee Kit

Contains heat shrink tubing and other materials to make one splice or one tee connection. Also includes one end seal.



SRK08 Plug in 120V Connection Kit with GFEP Device

Contains labels, GFEP protection device with 120V plug, cable ties, crimp type connectors, heat shrink tubing and labels. Includes one end seal.



SRK12 End Seal Kit

Contains heat shrink tubing and other materials to make two end seals.



SRK03 Tape

Pipe trace tape and labels.



SRK14

3M VHB double sided acrylic foam pads
For use with SRK13 clips in metal gutter

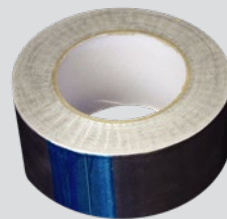

SRK04

2.5" x 50 yards 2 mil Foil tape



SRK13 Clip

Roof clip for mounting cable

SRK15 Downspout

Downspout hanger and cable ties.



SRK17

11 & 13mm Gel end seal

MODEL	UPC	DESCRIPTION	WEIGHT
SRK00	40462	Hard wired power connection kit, includes end seal	0.3 lbs.
SRK02	40461	Connection kit, includes end seal	0.3 lbs.
SRK03	40464	Pipe trace tape (66ft) and 10 labels per package	1.0 lbs.
SRK04	61713	2.5" x 50 yards 2 mil foil tape	1.6 lbs.
SRK08	40466	Plug in 120V connection kit with GFEP device, includes end seal	1.0 lbs.
SRK10	40468	Weatherproof splice/tee kit, includes end seal	0.2 lbs.
SRK12	40470	End seal kit (2 per package)	0.1 lbs.
SRK13	40472	Roof clip (25 per package)	0.2 lbs.
SRK14	40473	3M VHB double sided acrylic foam pads (25 per package)	0.1 lbs.
SRK15	40476	Downspout hanger and cable ties	0.3 lbs.
SRK17	40477	11 & 13mm Gel end seal	0.1 lbs.

Roof/Drain De-Icing System



With the introduction of membrane & rubber roofing materials, the attachment of de-icing cables to the roof has presented a dilemma for roofing specialists. A major concern of property owners is the damage caused by ice damming. The roof drain de-icing jig was created with several things in mind. The jig is lightweight, inexpensive, and uses SRG series de-icing cable without anchoring through the roof membrane. It is easy to customize to job conditions in the field. It adapts easily for use in canales and scuppers on southwestern and flat roof style architecture, both commercial and residential. It is easy to install with small hand tools.



4RDDJ2



6RDDJ2



3625R14 RAY

MODEL	UPC	DESCRIPTION
4RDDJ2	40509	Canale/Scupper Jig, consists of 1 frame and 4 rays
6RDDJ2	40510	Flat Roof Drain Jig, consists of 1 frame and 6 rays
3625R14 RAY	40511	Cable Keeper / RDDJ-Grid

Call for availability on additional ETI controls not shown above.

Controls & Sensors

Roof & Gutter De-Icing Controls



CWR IceFree™



GIT-1



DS-2C /DS-224



DS-8C /DS-824C



CDP-2

MODEL	UPC	DESCRIPTION
DS-2C	42331	Rain/Snow controller w/built-in sensor, 100-277V - 30amp w/Adjustable Temperature Trigger Points, used for snow melt cable projects
DS-5C	42332	Rain/Snow controller w/built-in sensor, 100-277V - 2-30amp w/Adjustable Temperature Trigger Points, used for snow melt cable projects
DS-8	48480	Gutter ice melting controller, NEMA 3R, 120/208/240V, 30amp, adjustable temperature range 34°F to 44°F, 1/2" hub
DS-8C	42335	Gutter ice melting controller, NEMA 3R, 120/208/240/277V, 30amp, adjustable temperature range 34°F to 44°F, 1/2" hub
DS-8/24	40481	Gutter ice melting controller, NEMA 3R, 24V, 30amp, adjustable temperature range 34°F to 44°F, 1/2" hub
DS-9C	42426	Gutter ice melting controller, NEMA 3R, 120/208/240/277V, 2-30amp, adjustable temperature range 34°F to 44°F, 1/2" hub
CDP-2	40482	Indoor sensor control display, manual/auto/standby modes, includes 18" lead
CS-1	40483	Control cable for CDP-2 control panel, 18" lead
CS-50	40484	Control cable for CDP-2 control panel, 50 ft. lead
MG-3	40485	Replacement sensor for DS controller
GIT-1	40508	GIT-1 Gutter De-Icing sensor
CWR-120	48710	CWR IceFree Controller with 6 ft. cord and grounded plug (See Page 1)

Call for availability on additional ETI controls not shown above.

Pipe Freeze Protection



IFC12



TRF115-005

MODEL	UPC	DESCRIPTION
TRF115-005	40486	Freeze protection thermostat, weatherproof with 5 ft. remote bulb & capillary, 25 amp at 120/208/240V, 22 amp at 277V, adjustable temp 0°F, suitable for 24 VAC operation (w/Power-On indicator light)
IFC12	40490	Plug in fixed thermostat, 120V, 15 amp, on at 35°F off at 45°F (12/case)

Call for availability on additional ETI controls not shown above.

Snow Melt Controls



SIT-6E



SMNPLT

MODEL	UPC	DESCRIPTION
SCIT-6E	40505	SIT-6E Pavement Sensor (requires 23832 Pavement Sensor Housing)
23832 Sensor Housing	40506	Pavement Sensor Housing (not pictured)
SMNPLT	40507	Snow Melt Name Plate (per NEC 426.13 requirements)

Call for availability on additional ETI controls not shown above.



Smart Comfort Solutions



HIGH VELOCITY DRUM FANS

High Velocity Drum Fans Direct Drive



Model Code:

DFC -24 D -S
A B C D

A: Series
B: Fan Diameter
(24", 30", 36")
C: D = Direct Drive Motor
D: S = Swivel Base (optional)



- 2-speed switch Direct drive motor
- 3 aerodynamically balanced blades
- Convenient handles & Rugged wheels
- Meets OSHA 1910.212(A)(5) requirements
- 9 Ft, 120V grounded cord & plug
- Scratch resistant, powder-coated finish
- Built-In cord wrap
- Heavy duty 22 gauge steel drum
- Reinforced with tubular cross braces
- Standard color: King Green
- Optional swivel base available
- 1-year limited warranty

The King High Velocity Drum Fans - Direct Drive

King High Velocity Direct Drive Drum Fans are great for heavy duty air circulation in light duty commercial applications where an economical solution is needed. They are dependable, running on less power and require less maintenance compared to other motors. The 2-speed, direct drive fan has 3 aerodynamically balanced aluminum blades for even, steady airflow and to provide maximum airflow and motor efficiency. The scratch-resistant King green finish looks sharp and is easy to clean. Rugged flat-free wheels with metal hubs last for years and roll easily over uneven surfaces. Cord wrap for convenient storage. UL listed.

Ordering Information

STOCK CODE	UPC #093319	MODEL NUMBER	DESCRIPTION	CFM	WT. (lbs.)
A	32705	DFC-24D-S	Drum Fan, 24" Direct Drive, Swivel	7300	39.04
A	32706	DFC-24D	Drum Fan, 24" Direct Drive, Fixed	7300	38.53
A	32707	DFC-30D-S	Drum Fan, 30" Direct Drive, Swivel	8800	54.96
A	32708	DFC-30D	Drum Fan, 30" Direct Drive, Fixed	8800	47.33
A	32709	DFC-36D	Drum Fan, 36" Direct Drive, Fixed	11630	65.74

Direct Drive

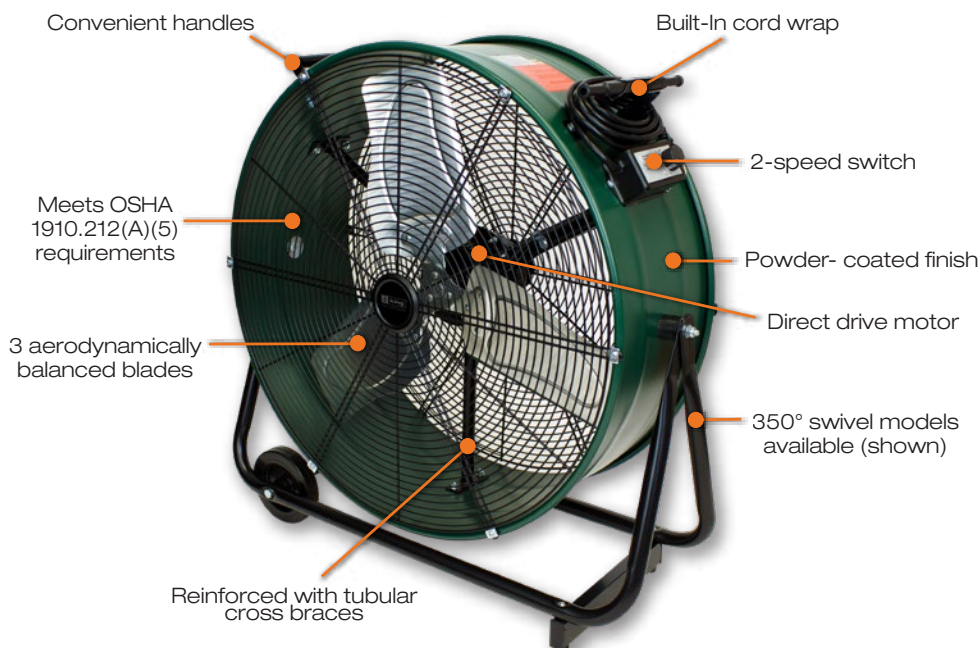

High Velocity Drum Fans Belt Drive



Model Code:

DFC	-24	B	-S
A	B	C	D

A: Series

B: Fan Diameter
(36", 42", 48")

C: B = Belt Drive Motor



- 2-speed switch Belt drive motor
- Incredibly quiet for its size & performance levels
- 4 aerodynamically balanced blades
- Convenient handles & Rugged wheels
- Meets OSHA 1910.212(A)(5) requirements
- 9 Ft, 120V grounded cord & plug
- Scratch resistant, powder- coated finish
- Built-in cord wrap
- Heavy duty 20 gauge steel drum
- Reinforced with tubular cross braces
- Standard color: King Green
- 1-year limited warranty

The King High Velocity Drum Fans - Belt Drive

King High Velocity Industrial Belt Drive Drum Fans were specifically designed for industrial applications where quality, performance, and durability are required. Rugged and reliable, they make less noise and use a lower power load, which gives the fan's motor a longer life. The 2-speed, belt drive fan has 4 aerodynamically balanced aluminum blades for even, steady airflow and to provide maximum airflow and motor efficiency. The scratch-resistant King green finish looks sharp and is easy to clean. Rugged flat-free wheels with metal hubs last for years and roll easily over uneven surfaces. Cord wrap for convenient storage. UL listed.

Ordering Information

STOCK CODE	UPC #093319	MODEL NUMBER	DESCRIPTION	CFM	WT. (lbs.)
A	32710	DFC-36B	Drum Fan, 36" Belt Drive, Fixed	11630	78.94
A	32711	DFC-42B	Drum Fan, 42" Belt Drive, Fixed	15800	96.01
A	32712	DFC-48B	Drum Fan, 48" Belt Drive, Fixed	17800	118.5

Belt Drive

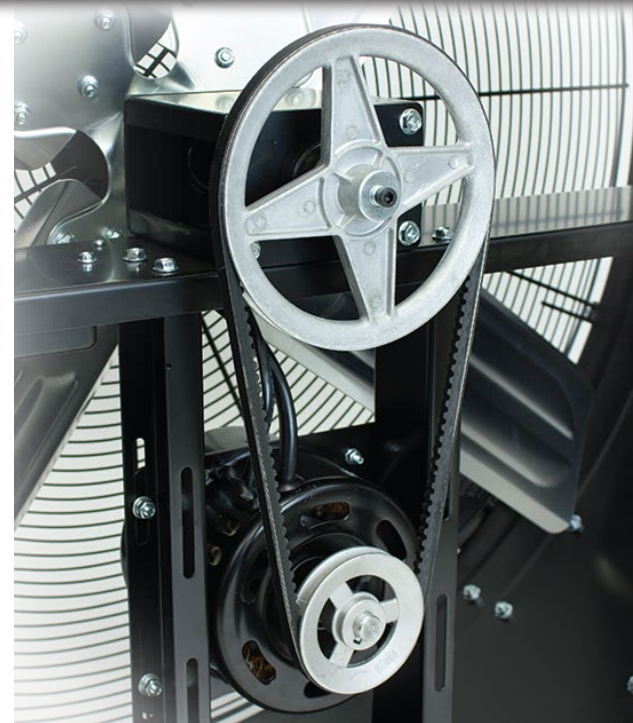
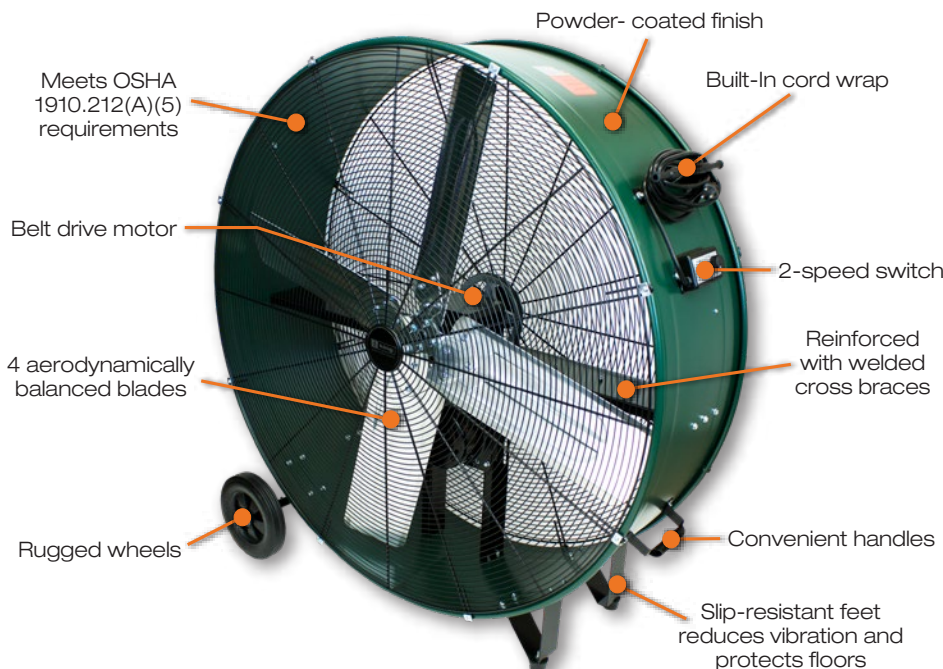

TV Rough-In TVR Series



- Fastened directly to studs
- Sturdy 14-gauge mounting bracket
- Adjustable trim ring for 1/2" or 5/8" drywall
- Mounting hardware for rough-in and TV
- Option cover, sold separately
- Rough-in dimensions 23-3/8" by 13-5/8"
- All A/C line power converges in one
- UL-approved divided junction box
- Dual voltage junction box

Rough-in mounting system for flat screen television

Make fast, simple work of flatscreen installation. Finally, a solution to age-old dilemma of confusion between line-voltage electricians and low-voltage installers. The TVR flat-screen premount bracket system becomes a simple, effective, easily-understood touchpoint for framers, electricians, and general contractors. Once the TVR flat-screen premount bracket is in place, all AC power, HDMI, and audio cables are terminated at the two-compartment junction box, ready for final trim-out. Using the TVR ensures that all potential elements are located properly, ready for a fast installation. The TVR pre-mount flat screen control center is the most comprehensive, efficient, and cost effective way to prepare for and install a flat screen.

Ordering Information

MODEL	UPC	DESCRIPTION	WEIGHT (lbs)
TVR01	20585	TV MOUNTING BRACKET, ROUGH-IN BACK PLATE, HARDWARE KIT	11.8
TVR01B	20586	DUAL VOLTAGE JUNCTION BOX AND MTG BRACKET	1.95
TVR01C	20587	OPTIONAL TVR COVER PLATE	5.3



Fast and easy: The back plate installs directly to the framing studs during the rough-in construction phase.



The TVR adjusts to fit any manufacturer's TV bracket (as shown) and offers a wide range of adjustment for final placement.



The optional cover can be installed to neatly cover the TVR mounting plate when not in use.



All connections hidden, leaving both contractor and homeowner feeling great.

Warranty Information

Warranty Information

The warranties herein set forth are in lieu of all other warranties expressed or implied, and shall not apply to any accessory not part of the product. King Electrical Mfg. Company will repair or replace, without charge to the original owner, any product found to be defective or malfunctioning within the warranty period.

Heaters Warranty Period

One Year: EFW-MW-Series, EKB Garage Heater, HSB & HLB Hot Water Baseboards, K-Series Baseboard, KAWH-Series Heaters, KCA, KLA & KLI Cabinet Heaters, KCB, KDIA & KDBA Draft Barriers, KDS-Series Ceiling Heaters, KT-MW Kickspace, LB & SB Draft Barriers, MKT Series, OK-Series Radiant Heaters, 120V Portable Fan Heaters, 240V Portable Shop/Garage Heaters, 120V Portable Baseboards, RH Radiant Heater, RSH Radiant Heaters, Thermostats and Controls, TVR Mount, U-Series Pump House Heater, W-Series.

Two Year: H-Series Hydronic Fan Heaters, HI-Series Boiler Conversion Heaters, KBS Unit Heaters, KCV Cove Heaters, KTW In-Counter Heater, LPWV Vandal Resistant, PKB Portable Unit Heaters,

Three Year: CK & CKL Plenum heaters, PAW-SS Stainless Steel Heater, PCK Portable Heaters, WHF Series, WHF-HM High Mount Heater, WHFC Ceiling Heater, PAW-SS Stainless Steel Heater, GH and SKB Unit Heaters.

Five Year: CB Ceramic Baseboards, DAW-Series, KB Unit Heaters, KBP-Series, KCC & KCF Cabinet Heaters, KF & KFS Electric Furnaces, KFUH Unit Heaters, LPW-Series LPWA-Series, LPWC-Series, PAW-Series, PX-Series, SL-Series.

Heating Cable Warranty Period:

One Year: CWP & CWR, Thermostats and Controls.

Two Year: SR & SRP

Ten Year: TC & TCM, SC & SCM

Twenty Year: FC & FCM

High Velocity Drum Fan Warranty Period:

One Year: Direct Drive, Belt Drive

Warranty Terms: This warranty requires the owner or his agent install the equipment in accordance with the National Electrical Code, any other applicable heating or electrical codes and the manufacturer's installation instructions. It further requires that reasonable and necessary maintenance be performed on the unit. Failure of proper maintenance by owner will void the warranty in its entirety. The company is not liable for any actions it deems to be abuse or misuse of the product. The Company shall not be liable for consequential damages arising with respect to the product, whether based upon negligence, tort, strict liability or contract. No other written or oral warranty applies, nor any warranties by Representatives, Dealers, Employees of King or any other person. King Manufacturing can be contacted by phone at 800-603-5464, fax 206-763-7738 or website www.king-electric.com. The company's minimum liability shall not in any case exceed the purchase price for the product claimed to be defective.

In Case of Product Failure: Contact King Electrical Mfg. at 800-603-5464. The owner will be required to provide, within the designated warranty period, the following information: model number, date of purchase, and a complete description of the problem encountered with product. Upon receipt of the aforementioned, the company will reply to the owner within a period not to exceed fifteen (15) working days, and will provide the action to be taken by owner. The customer shall be responsible for all costs incurred in the removal or reinstallation of products, including, but not limited to labor costs, and shipping costs incurred to return products to King Manufacturing. At their discretion, King Manufacturing will decide to either repair or replace the product, with no charge to the owner, with return freight paid by King.

Technical Support: 206-762-0400 extension 2

How To Select The Right Size Heater

How To Select The Right Size Heater

Confirm Your Voltage

Before selecting an electric heater, determine if the power supply is 120 volt or 240 volt.

How to check your voltage:

- The most accurate way to check your voltage supply is with a voltmeter.
WARNING: This test needs to be performed with the circuit breaker 'On'. If you are uncomfortable working with live electrical circuits, please consult an electrician.
- If you're replacing an old heater, identify voltage on the old heater label.
- Check your circuit breaker to identify either Single Pole 120 volt or Double Pole 240 volt.

Size Your Heater – Room Wattage Requirements

Simply follow the chart below to determine the wattage requirements for a particular room.

Step 1: Measure your room

Select the square footage closest to the room size you want to heat.

- Rooms with greater than average window space, increase wattage by 50%
- If wattage recommendation falls between two heaters, select the heater with higher wattage

Step 2: Age of Home

- Refer to the column with the age of your home.

General Requirements:

King Electric recommends approximately 6 watts per square foot for newer homes and 10 watts per square foot for older homes. It is recommended to add 2 watts per square foot for homes located in higher than average elevations or extreme cold climates.

Wattage Selection Guide

Square Footage of Room	Newer Home Watts* (6W/SqFt)	Older Home Watts**(10W/SqFt)
50	300	500
75	450	750
100	600	1000
125	750	1250
150	900	1500
175	1050	1750
200	1200	2000
225	1350	2250
250	1500	2500
275	1650	2750
300	1800	3000
325	1950	3250
350	2100	3500
375	2250	3750
400	2400	4000

(BTU = WATTS X 3.412)

*Newer home - Mostly 1980's to present, R19 walls, R30 floors and ceilings, standard windows thermal pane, 8 ft ceilings

**Older home - Prior to 1980, R11 walls, R19 ceilings, single pane windows, 9 ft ceilings

Select The Right Type Of Heater

How To Select The Right Type Of Heater

Fan heater or baseboard?

Space: A baseboard heater takes up more wall space than a fan-forced heater which can cause problems placing furniture. (For example: a 2250 Watt Pic-A-Watt® heater will provide as much heat as a 9 foot baseboard.)

Comfort: A fan-forced heater will heat a room within a few minutes whereas a baseboard will require 30 to 40 minutes. A fan-forced heater will also maintain a more even temperature because the fan will circulate air around the room. This reduces the severity of hot/cold temperature swings.

Noise: A baseboard heater has no moving parts and therefore is quieter than a fan heater. The small Pic-A-Watt® heater uses a squirrel cage blower which makes it almost inaudible.

Efficiency: A 1500 Watt baseboard uses the same amount of electrical power as a 1500 Watt fan heater. The difference is a fan heater gives more even heat throughout the room thereby reducing air stratification (hot air rising and not mixing with the cooler floor air). This process makes you feel cooler causing you to turn the baseboard thermostat to a higher temperature setting whereby it runs more often thus using more electric power than the same size fan heater. Every 1° a thermostat is turned up will raise a power bill 3.1%. As such, a baseboard set to 75°F will cost you 15.5% more than a fan heater set to 70°F.

Which fan heater to choose?

Use: If the heater will run often and be used as primary heating for the home King recommends using heaters with steel elements such as the Pic-A-Watt®. These elements carry a five year warranty and will hold up to the rigors of everyday use. For supplemental or occasional use open-coil elements work fine. If budgetary constraints are of primary importance open-coil heaters are the least expensive.

Noise: A propeller-type fan will make more noise than a squirrel cage fan. Open-coil elements make more noise than steel mass elements (Pic-A-Watt®) due to the rate of heat exchange with the air. For large rooms, two small heaters will be quieter than one large heater.

How To Size The Heating Circuit

AMPS	VOLTS	WATTS	WIRE SIZE	CIRCUIT PROTECTION
12	120	1,440	#14/2	15 Amp – 1-Pole
16	120	1,920	#12/2	20 Amp – 1-Pole
12	240	2,880	#14/2	15 Amp – 2-Pole
16	240	3,840	#12/2	20 Amp – 2-Pole
24	240	5,760	#10/2	30 Amp – 2-Pole
32	240	7,680	#8/2	40 Amp - 2 Pole

- According to the National Electric Code heating circuits are considered a continuous load and therefore must be derated by 20%. (For example: a 20 Amp heating circuit cannot have more than 16 Amps of load connected.)
- 120 Volt heaters require 1-Pole circuit breakers; 240 Volt heaters need 2-Pole breakers.
- Use 2-wire cable with ground (Romex™ or BX).
- When placing multiple heaters on a circuit do not exceed the wattage listed for the corresponding wire and circuit breaker size. (For example: 2-1000W & 1-1500W, 240V heaters = 3500 Watts total. These 3 heaters would require 12/2 wire and a 20 Amp 2-Pole breaker if they were to all be placed on the same circuit. If more heaters are needed either run a new circuit or increase the wire and breaker size to accommodate the load.)
- A 1500 Watt heater will cost the same to run whether it is 120 or 240 Volt. 240 Volt heating circuits are more common because, as the chart shows, you can place more heaters on a 20 Amp 240 Volt circuit (maximum of 3840 Watts) versus a 120 Volt circuit (maximum of 1920 Watts).
- 120 and 240 Volt heaters are not interchangeable. A 240 Volt heater run at 120 Volt will produce 25% of the rated wattage. A 120 Volt heater run at 240 Volt will be destroyed and poses a severe fire hazard.
- What voltage are my heaters?

One breaker indicates 120 Volt is feeding your heater.

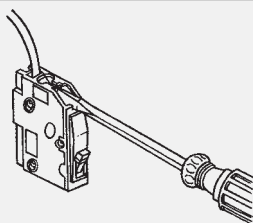

Two breakers tied together indicates a 240 Volt circuit feeding your heater.

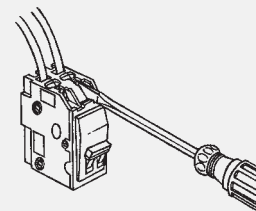

Total Amperage Rating Chart

Total Amperage Rating Chart

Power KW	120V (1)	208V (1)	208V (3)	240V (1)	240V (3)	277V (1)	480V (1)	480V (3)	600V (1)	600V (3)
0.3	2.50	1.45	0.83	1.25	0.72	1.09	0.63	0.36	0.50	0.29
0.4	3.34	1.92	1.11	1.67	0.97	1.45	0.84	0.49	0.67	0.39
0.5	4.17	2.41	1.39	2.09	1.21	1.81	1.05	0.61	0.84	0.49
0.6	5.00	2.89	1.66	2.50	1.45	2.17	1.25	0.72	1.00	0.58
0.75	6.25	3.61	2.09	3.13	1.81	2.71	1.57	0.91	1.25	0.72
0.8	6.67	3.85	2.23	3.34	1.93	2.89	1.67	0.97	1.34	0.77
1	8.34	4.81	2.78	4.17	2.41	3.61	2.09	1.21	1.67	0.97
1.2	10.00	5.77	3.34	5.00	2.89	4.34	2.50	1.45	2.00	1.16
1.25	10.42	6.01	3.47	5.21	3.01	4.52	2.61	1.51	2.09	1.21
1.4	11.67	6.73	3.89	5.84	3.38	5.06	2.92	1.40	2.34	1.35
1.5	12.50	7.22	4.17	6.25	3.61	5.42	3.13	1.81	2.50	1.45
1.6	13.34	7.70	4.45	6.67	3.86	5.78	3.34	1.93	2.67	1.54
1.75	14.59	8.42	4.87	7.30	4.22	6.32	3.65	2.11	2.92	1.69
2	16.67	9.62	5.56	8.34	4.82	7.22	4.17	2.41	3.34	1.93
2.25	18.75	10.82	6.25	9.38	5.42	8.13	4.69	2.71	3.75	2.17
2.5	20.84	12.02	6.95	10.42	6.02	9.03	5.21	3.01	4.17	2.41
3	25.00	14.43	8.34	12.50	7.23	10.83	6.25	3.61	5.00	2.89
4	33.34	19.23	11.12	16.67	9.64	14.44	8.34	4.82	6.67	3.86
4.5	37.50	21.64	12.50	18.75	10.84	16.25	9.38	5.42	7.50	4.34
5	41.67	24.04	13.90	20.84	12.05	18.05	10.42	6.02	8.34	4.82
6	50.00	28.85	16.68	25.00	14.45	21.66	12.50	7.23	10.00	5.78
7.5	62.50	36.06	20.84	31.25	18.06	27.08	15.63	9.03	12.50	7.23
8	66.67	38.47	22.23	33.34	19.27	28.88	16.67	9.64	13.34	7.71
9	75.00	43.27	25.01	37.50	21.68	32.49	18.75	10.84	15.00	8.67
10	83.34	48.08	27.79	41.67	24.09	36.11	20.84	12.05	16.67	9.64
12	100.00	57.70	33.25	50.00	28.90	43.33	25.00	14.45	20.00	11.56
14	116.67	67.31	38.91	58.33	33.72	50.54	29.17	16.86	23.33	13.49
15	125.00	72.12	41.69	62.50	36.13	54.16	31.25	18.06	25.00	14.45
18	150.00	86.54	50.02	75.00	43.35	64.99	37.50	21.68	30.00	17.34
20	166.67	96.16	55.58	83.34	48.17	72.21	41.67	24.09	33.34	19.27
24	200.00	115.39	66.69	100.00	57.80	86.65	50.00	28.90	40.00	23.12
25	208.34	120.20	69.48	104.17	60.21	90.26	52.09	30.11	41.67	24.09
30	250.00	144.23	83.37	125.00	72.25	108.31	62.50	36.13	50.00	28.90
35	291.67	168.27	97.27	145.84	84.30	126.36	72.92	42.15	58.34	33.72
40	333.34	192.31	111.16	166.67	96.34	144.41	83.34	48.17	66.67	38.54
45	375.00	216.35	125.06	187.50	108.38	162.46	93.75	54.19	75.00	43.35
50	416.67	240.39	138.95	208.34	120.43	180.51	104.17	60.21	83.34	48.17
55	458.34	264.43	152.85	229.17	132.47	198.56	114.59	66.24	91.67	52.99
60	500.00	288.47	166.75	250.00	144.51	216.61	125.00	72.25	100.00	57.80
66	550.00	317.31	183.20	275.00	158.77	238.68	137.50	79.39	110.00	63.51

(1) Single Phase, (3) Three Phase

Heater Care And Information

Taking Care Of Your Heating System

At the start of each heating season clean and inspect each heater. **It is extremely important to remember to turn off the power at the circuit breaker before attempting any installation, maintenance or repairs. Failure to do so may result in serious electrical shock, burns or possible death.** Remove the grille on fan heaters. Clean any dust or lint from inside the heater with a vacuum cleaner, compressed air or soft bristle brush. Check that the fan spins freely. Between 5-10 years you may want to upgrade your thermostat, as the sensing element may not be as accurate as when new. The most accurate thermostat is listed as an anticipated model. If, in the future, you decide to remodel or add rooms to your home, you won't have to worry about the size of your heating system. With electric heat you can add to the heating system, in large or small increments.

Zone Control

Thermostat settings are a matter of personal preference. A few days of adjustments will help you determine the setting that is comfortable for you. Most people keep their living quarters at 68 to 72°F (20 to 22°C) and sleeping areas at 65°F (18°C). For energy conservation and financial savings it is wise to set living area thermostats back at night, but not below 60°F (16°C).

Temperature Versus Cost

When setting your thermostat, you may want to consider the relative cost of various temperatures. The chart at right shows how much higher your heating bill may be if you like temperatures warmer than 70°F (21°C).

	-3.1%	+3.1%	+6.2%	+9.4%	+12.5%	+15.6%	+18.7%	+21.9%	+25.0%	+28.0%	+31.0%
69°F	70°F	71°F	72°F	73°F	74°F	75°F	76°F	77°F	78°F	79°F	80°F
20.5°C	21.1°F	21.6°C	22.2°C	22.7°C	23.3°C	23.8°C	24.4°C	25°C	25.5°C	26.1°C	26.6°C

Ohm's Law

The relationship between Wattage (heat) output and the applied Voltage of electric resistance heating elements is determined by a precise physical rule defined as Ohm's Law which states that the current in a resistance heating element is directly proportional to the applied Voltage. Ohm's Law is traditionally expressed as:

$$I = E/R$$

Where: **I** = Amperes (Current)
E = Voltage
R = Ohms (Resistance)

The same equation using the conventional abbreviation for voltage is:

$$I = V/R$$

Where: **I** = Amperes (Current)
V = Voltage
R = Ohms (Resistance)

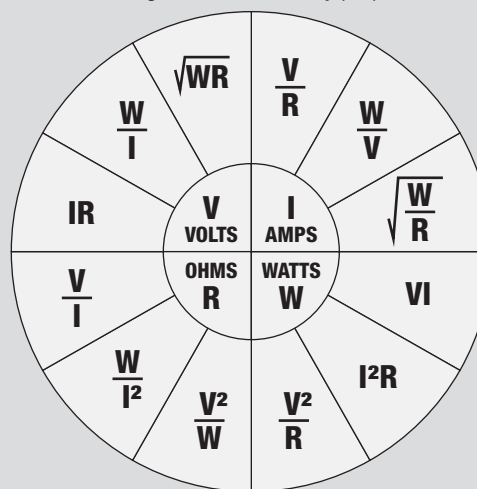

An unknown electrical value can be derived by using any two known values in one of the variations of Ohm's Law.

VOLTS Volts = $\sqrt{\text{Watts} \times \text{Ohms}}$	AMPERES Amperes = $\frac{\text{Volts}}{\text{Ohms}}$	OHMS Ohms = $\frac{\text{Volts}}{\text{Amperes}}$	WATTS Watts = Volts x Amperes
Volts = $\frac{\text{Watts}}{\text{Amperes}}$	Amperes = $\frac{\text{Watts}}{\text{Volts}}$	Ohms = $\frac{\text{Watts}}{\text{Amperes}^2}$	Watts = Amperes ² x Ohms
Volts = Amperes x Ohms	Amperes = $\sqrt{\frac{\text{Watts}}{\text{Ohms}}}$	Ohms = $\frac{\text{Volts}^2}{\text{Watts}}$	Watts = $\frac{\text{Volts}^2}{\text{Ohms}}$

Commonly Asked Questions/Glossary

Commonly Asked Questions:

Q. Will the room heat up faster if I put the thermostat on 90 degrees when I get home?

A. No. The thermostat is just an on-off switch that is temperature sensitive. The heater is either on or off.

Q. My baseboards are on outside walls, should fan heaters be also?

A. No. A fan heater, recessed into an outside wall, will create extra heat loss and air leakage for that room. An inside wall, facing a cold window, is the best location.

Q. My thermostat is above my fan-heater. Why?

A. The fan heater blows warm air away from itself and into the room. By the time the warm air has recirculated and reached the thermostat above the heater, a comfortable room temperature has been achieved.

Q. Will my electric bill be lower if I use 120 volt heaters?

A. No. Same size 120 volt and 240 volt heaters will use the same amount of power, measured in watts or kilowatts. Your electric company charges by kilowatt hours.

Q. Should I clean my heater?

A. Yes. Once a year you must clean and inspect your heaters. Please refer to the section "Taking Care of Your Heating System" on the previous page. You may request a copy of the operation & maintenance for your heater if you have lost it.

Q. Why does my new heater produce smoke when I turn it on?

A. In the manufacturing process, a light lubricant is used, which will burn when the heater is energized. The smoke will stop after the heater has fully heated. There is no cause for alarm. It is recommended to open a window during initial operations.

Q. If I need to replace my heater, can I use a higher wattage heater?

A. Your electrical system was sized for the original heater's wattage. A smaller wattage heater would be OK, but a larger wattage heater may create a hazard.

Q. Are King heaters actually made in Seattle, Washington?

A. Yes. Since 1958 we have made quality residential, commercial and industrial heating products in the same location.

Glossary

Open Coil Element: An open-coil element using Nickel-Chromium wire that can handle very high temperatures. The coiled wire maximizes the surface area for efficient heat transfer.

Dual Open Coil Element: Same as above, except the element wattage can be reduced in half by cutting one of the element wires.

Pic-A-Watt Element: The core of the King heating line. Developed in 1988 it has worked flawlessly ever since. It is made from steel elements brazed onto steel plate fins making for a long-lasting maintenance-free heater. The multiple wattage feature allows the exact wattage needed for any room to be selected.

Ceramic Element: This core is made of extruded ceramic insulators that increase thermal mass helping improve even heating. The liquid-free design increases safety.

Spiral Steel Fin Element: These steel element tubes have continuous fins that spin to create one of the highest quality, longest-lasting elements on earth.

C-Frame Motor: C-Frame motors are inexpensive and commonly used in appliances. King motors contain a large oil reservoir that helps prolong the motor life and reduce maintenance.

Efficiency Motor: A unit bearing motor is a heavy-duty long-lasting motor. It uses a fraction of the energy that a C-Frame motor does, thereby saving you money on heating bills. This motor typically runs 15–20 years and never requires oiling. It is either long-lasting cast iron or standard economy-cast aluminum.

Aluminum Fan Blade: King uses aluminum fan blades which are noncombustible. The fan is an impeller type: it draws room air into the heater and then blows out heated air.

Squirrel Cage Blower: A long cylindrical blower that keeps the heater quiet. Recommended for areas where heater noise would be unwelcome, such as bedrooms and dens.

Built-In Thermostat: The heater comes with factory installed thermostat.

Smart Limit Protection: Patented safety system shuts the heater off if an overheat condition occurs. Reset is allowed by turning off the thermostat.

Stainless Steel: An excellent 304 grade, corrosion-resistant stainless steel. Perfect for chemical or saltwater environments.

Radiant Heat: A radiant heater provides sun-like warmth. The heat radiates from the heating element warming objects that are nearby.

Convection Heat: This type of heater has no fans, instead heating by the natural process of warm air rising off the element. Place on outside walls to prevent cold window drafts.

Hydronic: The newest heaters in the King product line, using the warmth of hot water circulating from a home's hot water tank or boiler.

Quiet Running: The quietest heaters in the King product line.

A Brief History



1956: In 1956 the electricity industry launched the “Live Better Electrically” (LBE) campaign, featuring a young Ronald Reagan touting the benefits of clean electricity, with the goal of converting American homes to 100% electric power.

1958: By 1958, electric heat was seen as a new frontier. Robert E. Wilson, founder of King Electrical MFG Co. wanted to be part of this new revolution and saw the opportunity to bring high quality all electric heating products to the market. Typical heating systems (coal, oil, and kerosene) were usually dirty, smoky and smelled terrible. Electric heat was the new, clean, flameless heating system, eliminating foul-smelling fuels and requiring no maintenance. After a successfully landing a military housing contract to outfit 5,000 military family homes, King’s electric baseboard heater was born. The public embraced it and millions of homes replaced their huge basement furnace with small baseboard heaters under the windows.



1963: Business was booming and soon KING outgrew its small factory location in South Park, a south Seattle suburb. Seattle had just hosted the 1962 World’s Fair giving millions of Americans their first look at the Pacific Northwest. After the fair one of the international pavilion buildings was moved to a lot close to KING; offices were added and the new KING factory was born.

1968: By 1968, over 30 different manufacturers of electric heat had launched into the business. Many innovations came and went, but only the strongest would survive. King introduces the KB unit heater and KCC cabinet heater product lines.

1970s: KING continued to expand distribution by adding warehouses across the United States to expedite delivery to a rapid growing market share. The international market steadily increased and several large distributors were set up in Canada, South America, and various other countries. King introduces the KFS electric furnace product line.

1984: The first small fan heaters (W series) were developed, again shifting the way Americans heat their homes. With improved air circulation and a compact design, these heaters were quickly becoming the industry standard.



A Brief History

1986: Everything changed with the invention of the Pic-A-Watt® series of heaters. A new class of heaters, that allowed customers to select the exact wattage, tailoring the heater to an area's specific heating requirements. An industry first.

1999: King develops and introduces the soon to be patented Smart Limit Protection (SLP) safety limit. The safety standard of the industry today.

2007: A big year for KING. Dean Wilson formerly with GE is named CEO, and daily management of the business is now run by brothers Dean, Brad and RJ Wilson. As most competitors move production offshore, KING makes the decision to significantly invest in new automated equipment to keep production in the USA. The C5 Tourette press is purchased allowing for 24/7 sheet metal production. King introduces line of electronic thermostats, the first thermostats in the market designed and built by a heating manufacturer.

2008: King Electric expands product line to include fan-forced hydronic heating.

2010: Construction is finished on 40,000 sqft warehouse and distribution center in Seattle, WA. King launches comprehensive line of Electric Heating Cables.

2013: King launches new industry leading line of Garage Heaters, effectively creating a new category for the electric heat market. King purchases second C5 machine, effectively doubling sheet metal production capacity.



2015: King launches ECO2S 2-Stage Heaters – ECO2S Works Smarter, Not Harder. KING launches the ATMOZ WIFI, connected thermostats with smart phone app control, for line voltage heaters.

2018: King Celebrates our 60 Year Anniversary of Made in America Comfort.

Pic-A-Watt
Selectable Wattage Element®



 **HYDRONIC**



We believe experience matters.

Fan Driven Heaters

W series fan forced wall heater.....	1-2
WHF series fan forced wall heater.....	3-4
PAW series fan forced wall heater.....	5-7
PAW Ultra series fan forced wall heater	8
PX series fan forced wall heater.....	9-10
PX ECO2S series electronic fan forced wall heater	11-12
WHF-HM series fan force high mount wall heater	13-14
SL series slim line surface mount wall heater	15-16
EFW-MW economy large wall heater.....	17-18
LPW series 2 ComfortCraft large wall heater	19-20
LPW ECO2S series Pic-A-Watt large wall heater.....	21-22
LPWVandal-Resistant wall heater.....	23-24
LPWA Architectural wall heater	25-26
KT-MW series kick-space heater	27-28
KTW series convertable multi-watt kick-space heater ..	29-30

Ceiling Heaters

WHFC series ceiling mount heater	31
LPWC series Pic-A-Watt ceiling mount heater	32
KDS series large ceiling diffuser heater.....	33-35

Baseboard Heaters

K series baseboard heater	36-38
CB series ceramic baseboard heater.....	38-40
Baseboard shields	38

Cove Heaters

KCV series cove heater	41-42
------------------------------	-------

Thermostats

Electronic thermostats	43-51
Mechanical line voltage thermostats.....	52-53
Hydronic thermostats.....	160-162
Specialty thermostats	54

Personal Portable Heaters

KP series portable baseboard heater.....	58-59
Fan forced personal portable utility/shop heater	55-57, 60-63

Radiant Heaters

RSH series radiant heater	64
RH series Detroit radiant heater	65-69
OK series radiant heater	70-71

Pumphouse Heaters

U series pumphouse heater	72
---------------------------------	----

Cabinet Heaters

KCF/KCF Safetouch series small fan forced cabinet heater.....	73-75
KCC series small convection cabinet heater	76-77
KCA series cabinet unit heater	78-80
KLA series high density architectural cabinet heater	81-82
KLI series high density architectural sloped top cabinet heater.....	83-84

Draft Barrier Heaters

SB series draft barrier heater	85-86
LB series draft barrier heater	87-89
KDBA series heavy-duty steel architectural draft barrier heater....	90-91
KDIA series steel sloped top architectural draft barrier heater	92-93

Unit Heaters

EKB series economy garage/shop heater	95-96
KBP series compact heavy duty unit heater.....	97-98
GH series compact heavy duty unit heater	99-100
SKB series unit heater	101-102
KB series unit heater	103-106
KB-ECO2S series electronic unit heater	107-108
KB-Platinum & Double series electronic unit heater	109-111
KBS series stainless steel unit heater.....	112-113
KFUH series high capacity unit heater	114-116

Plenum/Explosion Proof Heaters

CK series plenum heaters	117-119
CKL series large plenum heaters.....	120-123
FX5 series explosion proof heaters.....	124-127
CX1 series explosion proof heaters	128-130

Industrial Portable Heaters

PKB series portable unit heaters	131-132
PCK series heavy-duty portable unit heaters	133-134

Product Categories Index

Electric Furnace

KF/KFS series electric furnace	135-139
KFS Endura Pro series electric furnace.....	140-141

Marine Heaters

PAW-SS Pic-A-Watt stainless steel marine heaters	142-143
DAW-SS Dial-A-Watt stainless steel marine heaters.....	144
MKT-SS stainless steel kick-space heaters.....	145

Electric Duct Heaters

R series in-line duct heating system	146, 149
E series flippable electric duct heater.....	147, 149
DHC/DC series electric duct heater	148-149

Hydronic Heaters

HLB hydronic draft barrier heaters	151-154
HSB hydronic draft barrier heaters	151-154
H series hydronic fan wall heaters	155
HT series hydronic kick-space heaters.....	156-157
HM/HME series hydronic medium sized wall heaters	158
HL/HLE series hydronic large sized wall heaters	159
HW/HWP/HWPT series hydronic thermostats.....	160
HB/HBP series electronic hydronic thermostats.....	161-162

Boiler Conversion Heaters

HI series boiler conversion heaters.....	163
--	-----

Electric In-Floor Heat

FC series electric In-Floor cable	166
FCM series electric In-Floor mats.....	167
Thermostats & Accessories.....	168

Thermal Storage

TC series thermal storage cable.....	170
TCM series thermal storage 24"/30" & 36" mats.....	171
SC series snow melt cable	173
SCM series snow melt 208/240/480V 24"/30" & 36" mats.....	174-176

Pipe Freeze Protection

SRP series pre-assembled self regulating pipe trace cable	178
CWP series constant wattage pipe trace cable	179
SR series self regulating pipe trace cable.....	180-181
CT series self regulating pipe trace cable.....	181

Roof/Gutter De-Icing

SRP series pre-assembled self regulating de-icing cable	183
CWR series constant wattage roof/gutter de-icing cable	184
CWR series IceFree™ controller	184
SR series self regulating roof/gutter de-icing cable	185
CT series self regulating roof/gutter de-icing cable	186

Charts & Tables

SRP pre-assembled self regulating cable.....	187-188
SR self regulating cable	189
SR self regulating cable pipe freeze protection.....	190-191
SR self regulating cable roof/gutter de-icing	192-193

Controls, Sensors & Accessories

SnowFree™ controller snow melt system kit.....	194
PYRO snow melt de-icing system.....	195-196
PYRO FPC freeze protection controller.....	197
PYRO pipe trace system.....	198
SR/SRP accessories.....	199
Roof/drain de-icing system	200
Roof & gutter de-icing controls	201
Pipe freeze protection	201
Snow melt controls.....	201

High Velocity Drum Fans

DFC series direct drive drum fans	203
DFC series belt drive drum fans	204

TVR

SRP series rough-in mounting system for flat screen television.....	205
---	-----

Alpha-Numeric Index:

1E30	54	HL/HLE	159	KLA	81-82	PX	9-10
1F56W	54	HM/HME	158	KLI	83-84	PX ECO2S	11-12
1F57	54	HP	50	KP1215-ECO	58	PYRO De-Icing	195-196
ATMOZ WiFi	43-44	HSB	153-154	KP	59	PYRO Pipe Trace	198
AUTONOMOUS (K702) ...	51	HT	156-157	KPH	59	R (Duct)	146,149
CB Baseboards	39-40	HW	160	KT-MW	27-28	RH	65-69
CK	117-119	HWP	160	KTW	29-30	RSH1215	64
CKL	120-123	HWPT	160	LB	87-89	SB	85-86
CWP	179	K101/K102	52	LPW	19-20	SC	173
CWR	184	K101-C	52-53	LPWA	25-26	SCM	174-176
CX1	128-130	K302PE	45	LPWC	32	SFC	194
DAW-SS	144	K322E	46	LPW ECO2S	21-22	SFCM	194
DFC Direct Drive	203	K312RELAY	45-46	LPWV	23-24	SIMPLSTAT (K700)	47
DFC Belt Drive	204	K Baseboards	36-38	MKT-SS	145	SKB	101-102
DHC / DC (Duct) ...	148,149	KB	103-106	OK	70-71	SL	15-16
E (Duct)	147,149	KB ECO2S	107-108	PAW	5-7	SR De-Icing	185-186
EFW-MW	17-18	KB Platinum	109-111	PAW-SS	142-143	SR Pipe Trace	180-181
EKB	95-96	KBP	97-98	PAW Ultra	8	SRP De-Icing	183
EP-3	54	KBS	112-113	PCK	133-134	SRP Pipe Trace	178
ES/ESP	48	KCA	78-80	PGH2448-ETB	63	TC	170
FC	166	KCC	76-77	PGH2440TB	63	TCM	171
FCM	167	KCF	73-74	PGH2448TB	63	TF115	54
Floor Heat Thermostats	168	KCF Safe Touch	75	PH-2	56	TVR	144
FPC	197	KCV	41-42	PH-7	55	U	72
FX5	124-127	KDBA	90-91	PH-16	56	W	1-2
GH	99-100	KDIA	92-93	PHM-1	57	WHF	3-4
H	155	KDS	33-35	PHTR-9	57	WHFC	31
HB	161	KF	135-139	PKB	131-132	WHF-HM	13-14
HBP	162	KFS	135-139	PSH1215T	61	WR	49
HI	163	KFS Endura	140-141	PSH2440TB	62	WRP	49
HLB	151-152	KFUH	114-116	PUH1215T	60		

Industrial Heaters • Residential Heaters • Commercial Heaters • Garage Heaters • Marine Heaters • Hydronic Heaters • Electric Furnaces • Heating Cable • Roof/Gutter De-Icing • Thermostats

King: a technology leader.

Since 1958 King Electrical Manufacturing Company has been a leader in the heating industry, with several innovative patents. In this age of corporate conglomeration, big business and a global economy, King is still proudly family-owned.

In our over 60 years of business we have seen exciting changes in the comfort and convenience of heating products. Technology has improved to create exciting new possibilities for innovations in heating systems. King continues to emphasize research and development, product quality and genuine pride to ensure that our customers enjoy the best heating solutions possible.

Residential, commercial or industrial electric heat: at King we anticipate your needs and provide you with the best products and solutions!



REV_9-01-18
UPC#99514